

INSTRUCTION MANUAL  
MANUAL de INSTRUCCIONES

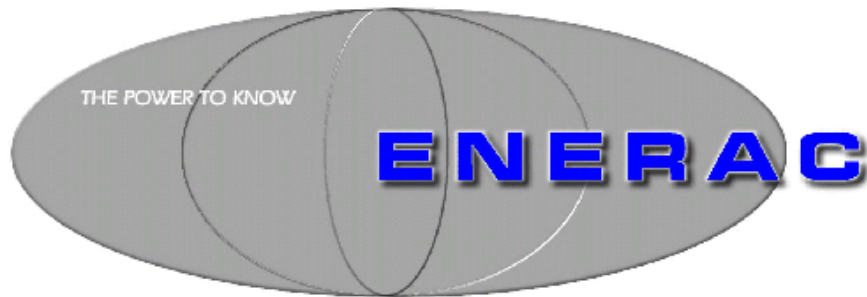

INTEGRATED EMISSIONS SYSTEM  
MODEL 700

ENERAC, INC  
67 BOND ST.  
WESTBURY, NY. 11590

**(800) 695-3637**  
**FAX (516) 997-2129**

Edition 2  
Hardware  $\geq$  F  
Software 2.6+

# TABLE OF CONTENTS

<b>LIST OF ABBREVIATIONS .....</b>	<b>5</b>
<b>OPTIONS.....</b>	<b>6</b>
<b>CHAPTER1</b>	
<b>FUNDAMENTALS.....</b>	<b>9</b>
<b>CHAPTER 2</b>	
<b>THE INSTRUMENT KEYBOARD.....</b>	<b>21</b>
<b>CHAPTER 3</b>	
<b>BASIC INSTRUMENT OPERATION.....</b>	<b>23</b>
<b>CHAPTER 4</b>	
<b>POWER REQUIREMENTS.....</b>	<b>25</b>
<b>CHAPTER 5</b>	
<b>SAMPLE FLOW &amp; SAMPLE CONDITIONING SYSTEM.....</b>	<b>27</b>
<b>CHAPTER 6</b>	
<b>SENSORS .....</b>	<b>37</b>
<b>CHAPTER 7</b>	
<b>ANALYZER SETUP .....</b>	<b>44</b>
<b>CHAPTER 8</b>	
<b>INTERNAL DATA STORAGE .....</b>	<b>47</b>
<b>CHAPTER 9</b>	
<b>INTERNAL PRINTER .....</b>	<b>49</b>
<b>CHAPTER 10</b>	
<b>CALIBRATION.....</b>	<b>51</b>
<b>CHAPTER 11</b>	
<b>COMMUNICATIONS .....</b>	<b>57</b>
<b>CHAPTER 12</b>	
<b>MAINTENANCE.....</b>	<b>64</b>
<b>APPENDIX A</b>	
<b>MODEL 700 – SEM SERIES SPECIFICATIONS .....</b>	<b>68</b>
<b>APPENDIX B</b>	
<b>FIRMWARE PROGRAMMING.....</b>	<b>72</b>

# LIST OF ABBREVIATIONS

## PARAMETERS

AIR	Excess air
AMB TEMP	Ambient (room) temperature
CO	Carbon monoxide (a toxic gas)
CO <sub>2</sub>	Carbon dioxide – NDIR measurement OR calculated from O <sub>2</sub>
COMBUST	Combustible gases
DUTY	Duty cycle, % of operating parameter
EFF	Combustion efficiency (for boilers and furnaces, does not apply to engines)
FPS	Feet per second (stack gas velocity)
HC	Hydrocarbons (NDIR) measurement- calibrated to propane
N.A.	Parameter not available (no sensor installed)
NO	Nitric oxide (a toxic gas)
NO <sub>2</sub>	Nitrogen dioxide (a toxic gas)
NOX	Oxides of nitrogen (a toxic mixture of nitric oxide and nitrogen dioxide gases)
OXYGEN REF	Oxygen reference basis for correction of toxic gas concentration
SEM™	New type of compliance level toxic gas sensors
SO <sub>2</sub>	Sulfur dioxide (a toxic gas)
ST	Stack temperature
THERMAL EFF	Engine thermal efficiency (heat loss method of calculation, not the same as combustion efficiency)

## UNITS

PPM	Parts (of pollutant) per million (volume basis-dry)
MGM	Milligrams (of pollutant) per cubic meter
GBH	Grams (of pollutant) per (engine) brake horsepower-hour.
#/B	Lbs. (of pollutant) per million BTU (of fuel).
"	Inches of water (draft measurement).
%	Percent by volume dry basis



Analyzer is connected to charger/adaptor

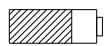

Unit operating on battery-remaining battery life indicated by solid

## OPTIONS- OPCOES

The ENERAC Model 700 is an extremely versatile emissions measurement system that meets practically all emissions requirements. It has been designed as a modular system, permitting the installation, in the field, of most of the various available options. This manual describes the complete instruments equipped with all the options.

O ENERAC modelo 700 é um sistema medidor de emissões extremamente versátil que atende a todos requisitos de emissão. O sistema é modular que permite instalação das variadas opções durante operação. Este manual descreve o instrumentos com suas opções.

Standard capabilities include ambient and stack temperature measurements, oxygen, carbon monoxide and draft measurements, over 100 internal storage buffers serial communications, and extensive help-screens. The variety of available options are separated into three categories:

O equipamento standard inclui medições de ambiente e “stack”, oxigênio, monóxido de carbono e “draft”, capacidade de armazenamento de até 100 medições.

Comunicação serial e menu de ajuda. As opções são separadas em três categorias:

### 1. ANALYZER SENSORS – SENSORES de ANALISE

A. Nitric oxide (NO) sensor - SEM type electrochemical sensor, with low temperature circuit for elimination of zero drifts

Oxido Nitrico (NO) Sensor- - sensor eletro- químico com baixa circuito de temperature para eliminar ‘drift’ em volta do valor zero

B. Nitrogen dioxide (NO<sub>2</sub>) sensor - SEM type electrochemical sensor- sensor eletro- químico

C. Sulfur dioxide (SO<sub>2</sub>) sensor - SEM type electrochemical sensor - sensor eletro- químico

D. Hydrocarbons / Carbon dioxide / carbon monoxide sensor bench – NDIR (infrared sensors) – sensor infra-vermelho

### 2. SAMPLE CONDITIONING SYSTEMS - SISTEMAS “SAMPLING” CONDICIONADO

A. Inconel probe with latex sample line and water trap

B. Inconel probe with Teflon or Viton sample line (10 –100 ft. long) and thermoelectric condenser

C. Inconel probe with permeation driver and Viton sample line (10-100 ft. long).

3. ACCESSORY OPTIONS - **OPCOES ACESSORIOS**

A. Integrated 2" fast graphic printer – **Rapida Impressora**

B. Additional pump for dual range and purging capability – **Bomba adicional para dupla medicos e capacidade de "purging"**

C. Heavy duty 6 "D" cell battery option – **Baterias tamanho "D"**

D. Custom fuel programming option – **Programacao de oleos customizados**

E. Enercom Windows™ software and Enerpalm software – **Programas sobre Windows e programa Enerpalm**

F. Bluetooth wireless communications – **Comunicacao sem fio Bluetooth**





# CHAPTER 1

---

## FUNDAMENTALS

The ENERAC Model 700 Integrated Emissions System is hand held state of the art analyzer designed to measure, record and transmit remotely combustion parameters used for the following tasks:

O ENERAC MODELO 700 e um sistema portatil feito para medir, graver and transmit parametros de combustao usado para as seguintes tarefas:

- A. To measure the oxide of nitrogen emissions from stationary combustion sources by means of high quality proprietary electrochemical sensors (SEM) in accordance with the EPA Provisional Reference Method (EMTIC CTM-022, CTM-030, & CTM-034) for portable NOX analyzers. **Medicao de emissao de Oxido de Nitrogenio de acordo com com as definicoes da EPA para medidores portateis de NOX**
- B. To measure the emissions of carbon monoxide, sulfur dioxide and oxygen sources from stationary and mobile combustion sources by means of high-quality proprietary electrochemical sensors (SEM). **Para medicoes de monoxide de carbono de fixo ou movel fontes de combustao atraves de alta qualidade sensores eletro-quimico.**
- C. To use NDIR technology to measure simultaneously, gaseous hydrocarbons as propane, carbon monoxide and carbon dioxide. **The Model 700 Meets EPA's Reference Method 25B Appendix A 40CFR60 "Determination of Total Gaseous Organic Concentration Using a Nondispersive Infrared Analyzer". O uso de tecnologia MDIR para medicao simultanea de gases hidrocarbonatos como propeno, monoxide de carbono e dioxide de carbono.. O modelo 700 atende ao método 25B da EPA- Appendix A 40CFR60.**
- D. To compute the emission rates in lbs/million BTU or lbs/hour (mass emissions) for carbon monoxide, NOX and sulfur dioxide, and in tons/day for carbon dioxide according to the EPA's 40CFR75 regulations for continuous emissions monitoring. **Para calcular a emissao em libras/milhoes BTU ou LIBRAS/HORAS para monoxide de carbono, NOX e dioxide de sulfuro, e em toneladas/dia para dioxide de carbono de acordo com regulamentacao de continua sypervisao de emissao da EPA (40CFR75)**

- E. To measure the stack gas velocity and volumetric flow rate and emission rates according to the **EPA Method 2, or Method 2C, Appendix A of 40CFR60.** **Para medir a velocidade do gas e volume de corrente e emissões de acordo com regulamentos EPA...**
- F. To assist the operator of a combustion source with the task of optimizing its performance and saving fuel. **Para ajudar o operador de uma fonte de combustão com objetivo de otimizar a combustão para economia de fontes de energia.**
- G. To be used as a management tool to assist the plant manager with keeping records and controlling costs. **A ser usado na administração assim como guardar dados de custo.**

The ENERAC Model 700 is the most advanced instrument of its type. It uses the latest proprietary (SEM INSIDE™) electrochemical sensor technology to measure emissions. To meet the accuracy requirements of the EPA reference methods, each SEM sensor is available with either one of two Precision Control Modules (PCMs), whose function is to select the measurement range (the ENERAC's analytical range is divided into low, mid and high ranges) that is appropriate for a particular measurement.

O ENERAC Modelo 700 é o mais avançado instrumento em sua categoria. Usa sensores eletroquímicos (SEMINSIDE) para medir emissões. Para a precisão necessária de acordo com a metodologia definida pela EPA, cada sensor contém um ou dois módulos (PCM) cuja função é para selecionar o domínio de sensibilidade (baixo, médio ou alto) de acordo com a medição necessária.

The ENERAC also uses the best available conditioning system technology (proprietary battery operated thermoelectric condenser, or permeation drier configuration) for accurate transport of the sample gas to the instrument. It also uses sophisticated electronics and programming design for increased accuracy and flexibility. It measures 3 temperatures and 6 different stack gases. It computes efficiency of combustion as well as excess air and carbon dioxide. In addition, it computes emissions in five different systems of units (PPM, milligrams/m<sup>3</sup>, lbs/MMBTU, grams/brake horsepower-hour and lbs/hour). It stores, prints and plots data. It communicates with a variety of other computers and PDAs located nearby Bluetooth™ technology and also via its RS-232 port, or remotely by telephone connection. It has a library of 15 fuels and a dedicated "HELP" button with diagnostic and help messages. It can operate either on its internal rechargeable batteries, AC power, or from 4 or 6 "D" cell alkaline batteries.

O ENERAC também tem o melhor sistema de exaustão para transportar o gás da forma mais acurada para os sensores. Ele usa uma sofisticada eletrônica e programas para aumentar flexibilidade e precisão. O equipamento mede 3 temperaturas e 6 diferentes gases. Calcula eficiência de combustão assim como dióxido de carbono e excesso de ar. Também, calcula emissões em 5 diferentes unidades (PPM, milligrams/m<sup>3</sup>, lbs/MMBTU, grams/brake horsepower-hour and lbs/hour).

Armazena, imprime informação e gráficos. Tem capacidade de se comunicar com uma variedade de computadores e PDA localizados em sua cercania através de protocolos Bluetooth e RS232, ou através de ligação telefônica. Contém livreria de 15 combustíveis e um botão de ajuda "Help" com diagnósticos e mensagens. Pode operar com internas baterias, corrente alternada externas ou 6 baterias alcalinas tamanho "D".

ENERAC has 25 years of experience in the manufacture and marketing of combustion and portable emission analyzers. The model 700 is based on this experience, together with the latest innovations in electronic and sensor technology. It also expresses our basic conviction that communications and artificial intelligence are the basic ingredients of the instrument of the future.

O ENERAC tem 25 anos de experiencia em producao e marketing the combustao e analizadores de emissao portateis.. O modlo 700 e baseado nesta acumulada experiencia junto com a ultimas novidades em eletronica e tecnologia de sensors. Inclui a nossa filosofia de inetligencia artificial e comunicacao sao os ingredients basicos do future.

The instrument operates basically as follows:

O instrument opera da seguinte forma:

You insert the probe in the stack of an operating combustion source such as a boiler, furnace or combustion engine. A pump located inside the instrument draws a small sample of the stack gas. The sample is conditioned before entering the analyzer. A number of sensors analyze the contents of the stack gas and its temperature and calculate and display the results. In addition, an S type pitot tube measures the velocity of the stack gases. The results can also be printed, stored or sent remotely to another computer either using the Bluetooth option or using its internal modem and a telephone line. The source operator makes the required adjustments based on the analysis of the stack conditions to optimize performance.

Voce coloca o “probe” dentro do “stack” emu ma fonte de combustao como “boiler”, chamine, ou motor d combustao. A bomba internal do instrument puxa um pequeno exemplar do gas. Os sensors analizam o conteudo, a temperaturae mostra os resultados. O tubo tipo S permite medicao de velocidade dos gases. Os resultados podem ser impressos, ar,azenados or transmitidos a outro computador usando internas opcoes como Blutooth, modem ou linha telefonica. A fonte do operador fazer os ajustes necessarios baseado na analise das condicoes do “stack”

## A. UNPACKING THE INSTRUMENT

Every ENERAC Model 700 includes as standard equipment:

Todo ENERAC modelo 700 inclui os seguintes equipamentos

- One Emissions Analyzer Model 700 (includes a roll of printer thermal paper).
- Um instrument modelo 700 ( inclui rolo de papel para impressora)

- One stack probe that includes the probe sample line and sample conditioning system, either a water trap or a thermoelectric condenser or a permeation drier.
- Um "probe" que inclui a linha usada para medicos, um "water trap" or condensador termoeletrico.
- One 14" inconel probe extension and Hastelloy X sintered filter.
- ???
- A battery charger / adaptor
- Carregador de bacteria com adaptador
- One extra Hastelloy X sintered filter and three disposable fiber filters.
- Um filtro Hastelloy X extra e tres filtros descartaveis
- One instruction manual.
- Um mabual de instrucoes
- One Enercom™ for Windows™ CD-ROM and instruction manual.
- Um CD com programa ENERCOM e manual do instrument.

## B. ENERAC MODEL 700 STARTING INSTRUCTIONS

1. Remove the instrument from its case and connect the thermo-electric cooler and probe to the unit. Or, if you have a permeation type probe, connect the permeation type probe to the instrument.  
 Remova o instrument da caixa e conecte o system de esfriamento thermo-eletrico e o "probe" a unidade. Caso vocetenha o probe de "permeation" , ligue ao equipamento.



2. Make sure the instrument is in a clean-air, room-temperature environment and turn it on. If you have a problem with the display initializing, please RESET the unit.

Verifique que o instrument esta em local de ar limpo e temperature ambiental. Ligue e caso haja problemas durante a inicializacao use o botao RESET.

3. The instrument has six electrochemical sensors, three infrared sensors (this is an option) and three temperature sensors.

O INSTRUMENTO tem 6 sensores eletro-quimicos, 3 infra-vermelhos (opcional) e 3 sensores de temperature,

4. IF YOU HAVE THE PERMEATION DRIER probe, you must wait a few minutes until the GREEN LED light which is mounted on the back of the probe turns on.

Caso voce tenha um probe que inclui uma secadora, voce e obrigado a esperar alguns minutos ate que a luz verde acenda. A luz esta montada atraz de "probe"

5. IF YOU HAVE THE INFRARED OPTION, you must press **ENTER** to begin an autozero countdown. Once the last line of the display states AUTOZERO COMPLETE, you are ready to use the instrument for your measurements.

Caso haja sensor infra vermelho voce tem que pressionar o botao "ENTER" para comecar o processo de "autozero". Quando o sistema indica o inal da operacao "AUTOZERO COMPLETE", o equipamento esta preparado para fazer medicos.

6. IF YOU DON'T HAVE THE INFRARED OPTION, you can bypass an initial autozero by pressing the **DISPLAY DATA** button. However it is recommended that you first zero the instrument before beginning your tests. To autozero the analyzer, first press the **ZERO SPAN** button, and then press **ENTER**. The display will automatically switch to the DATA DISPLAY mode and the last line will execute a countdown. At the end of the countdown you are ready to use the instrument.

Caso na opcao de sensors infra vermelho o usuario pode evitar o procedimento de "autozero" pressionando o botao "DISPLAY DATA". Recomendamos que sempre no inicio dos testes o usuario face "autozero". Para calibrar o instrument primeiro pressione o botao "ZERO SPAN" e depois pressione "ENTER". O monitor automaticamente modifica para o modo operacional de mostrar informacao e a ultima linha mostra a contagem regressiva. No final da contagem o equipamento esta pronto a fazer medicos.

7. If at the end of the countdown the display shows an error message for a particular sensor, contact the factory. The instrument will measure correctly all sensors that do not show an error message.

Caso no final da contagem o monitor mostra mensagens de erros para um sensor em particular, contate nossos estabelecimento. Caso nao haja mensagens de erros o equipamento esta pronto para medicos.

8. The LOW RANGE mode is the standard setting. In LOW RANGE mode, maximum concentrations are typically 2000 PPM for CO & NO, and 1000 PPM for NO<sub>2</sub> & SO<sub>2</sub>. If any of these parameters read OVER on the display, you must withdraw the probe from the stack immediately to prevent sensor saturation.

A medicao no dominio baixo e o mais comum. Neste dominio as concentracoes sao de 2000 PPM pra CO e NO. e 1000 PPM para NO2 E SO2. Caso apareca a palavra "OVER" no monitor ha necessidade de retirar imediatamente o "probe" para prevenir saturacao do sensor.

#### DUAL RANGE OPTION

#### OPCAO DE DUPLO DOMINIO

9. If you suspect HIGH concentrations of gases in your stack, or if you read OVER in the LOW RANGE, press the **PUMP** button to switch the instrument to its HIGH RANGE mode (This is an option).

Caso suspeite de concentracoes de gases altas, ou o monitor mostra a palavra "OVER", PRESSIONE O BOTAO "PUMP" que causa a mudanca prar o dominio alto

## D. IMPORTANT ADVICE

### IMPORTANTE CONSELHO

Most stack gases are hot, full of moisture, corrosive and laden with soot particles.  
**A maior parte dos gases são quentes, cheios de umidade, corrosivos.**

To make sure that your instrument will give you a long time of trouble-free performance, please observe the following recommendations.

**Para que o instrumento de um longo período de trabalho contínuo, por favor siga as seguintes recomendações**

1. Follow the instructions in your manual. – **Siga as instruções do manual**
2. Never use the instrument without the fiber filter located inline with the thermoelectric cooler or inside the permeation-drier probe. Operating the instrument without the filter will damage the pump and sensors. (This is a costly replacement!)

**Nunca use o instrumento sem o filtro de fibras localizado junto do esfriador termo-elétrico ou dentro do secador. Uso do equipamento sem os filtros criará danos na bomba e sensores.**

3. Prevent moisture from entering the analyzer. If the electrochemical sensors get wet they will not work until they can dry out. If the NDIR bench gets wet it will not read properly, and afterward, it may not autozero successfully. Once dried, typically overnight, the electrochemical sensors will usually recover. However, the NDIR optics will probably require cleaning, at the factory.

**Prevenha entrada de umidade no equipamento. Caso os sensores fiquem umedecidos não poderão operar até serem secados. Caso o NDIR fique molhado não poderá fazer leitura adequada e tampouco fazer o “autozero”. Seco, normalmente durante a noite, os sensores eletroquímicos se recuperarão por si, o NDIR óptico necessitará limpeza em nossos estabelecimentos.**

4. Do not expose the probe tip to open flame.

**Nunca faça contato do “probe” com fogo.**

5. Do not rest the stack probe’s hose on a hot boiler surface.

**Nunca deixe o “probe” em cima de superfícies quentes.**

6. Allow the probe tip to cool off and the instrument aspirate air before packing the probe.

**Permita que o “probe” esfrie e que o equipamento aspire ar antes de guardá-lo.**



7. Always be sure to use single span gas mixtures preferably with balance nitrogen when calibrating the sensors. Never use CO/NO or CO/SO<sub>2</sub> span gas blends!

Sempre use uma mistura de gases, de preferencia com Nitrogenio durante calibracao de sensors. Numca use misturas com CO/NO ou CO/NO<sub>2</sub>

Every ENERAC sold has stored in its memory information regarding manufacturing and sensor dates, as well as product identification, serial number of unit, version and original customer.

## D. AUTOZERO ERROES & BASIC TROUBLESHOOTING

<b>AUTOZERO ERRORS</b>		
<b>Channel</b>	<b>Possible Causes</b>	<b>Resolution</b>
(Electrochemical sensors) CO NO NO2 SO2 O2	Sensor has been recently exposed to gas and has not returned to zero.	Wait 10 minutes, monitor sensor voltage, and re-zero.
	Battery was dead, sensor has destabilized.	Charge battery, wait 24 hours for sensor to stabilize, and re-zero.
	Sensor cell is dead.	Call for a replacement.
Stack Temperature	Thermocouple is not connected	Check electrical connections running to the probe
	Thermocouple is hot	Probe tip should be cool
Stack Draft	Probe not connected	Draft voltage will be high. Connect probe and re-zero or ignore draft readings.
	Filters are dirty	Draft voltage will be low. Check filters
	Hose is kinked, possibly internally	Draft voltage will be zero. Check for suction at end of probe.
Infrared CO-CO2-HC 00	No response from infrared system	Autozero period must be at least 40 seconds. Zero the instrument again.
		(VELOCITY OPTION) Velocity probe is not connected
Infrared CO-CO2-HC XX	Infrared system is reporting error code XX	Infrared system may need maintenance.
Combustibles	Sensor is dead	Call for a replacement.
Velocity	Velocity probe is not connected	Check probe and connections.

<b>TROUBLESHOOTING</b>		
<b>Symptoms</b>	<b>Possible Causes</b>	<b>Resolution</b>
Analyzer will not turn on. (Screen is off)	Battery is dead.	Plug in the charger. Analyzer should turn on.
	Battery is not charging.	Check charger and jack. Check charger switch inside analyzer, next to paper roll.
	Internal initialization problem.	Reset the analyzer.
Analyzer turns on but screen is blue or faded.	Internal initialization problem.	Reset the analyzer.
	Analyzer is overheating.	Unplug charger. Check fan. Turn on & off to reinitialize.



## CHAPTER 2

---





### THE INSTRUMENT KEYBOARD

The Model 700 can be operated by using either:

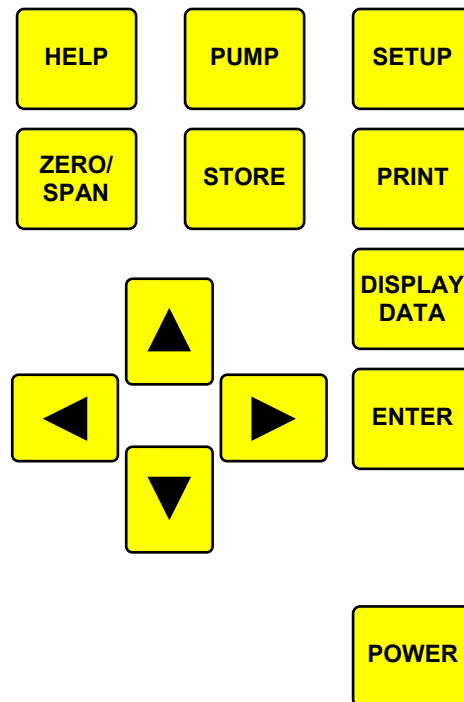
- The 13 button keyboard located on the face of the analyzer, or
- By the use of commands through its serial port.

A brief explanation of the instrument's buttons follows:



<b>HELP</b>	Context sensitive “help” key. Press this key for an explanation of observed parameters on the screen
<b>PUMP</b>	Controls Sample pump and /or dilution pump function. There are four states: A. Low range (sample pump on only), B. High range (sample and dilution pump on), C. Purge (dilution pump on, only), D. Off (both pumps are off).
<b>SETUP</b>	Controls all customization parameters (i.e. measurement units) for the analyzer
<b>ZERO/SPAN</b>	Controls calibration settings and zeroing of the analyzer’s sensors.
<b>STORE</b>	Controls operation of the analyzer’s internal storage buffers
<b>PRINT</b>	Executes print commands for the analyzer’s graphic printer
<b>DISPLAY DATA</b>	Displays the analyzer’s currently measured data in either of two font: A. Small fonts (all data displayed simultaneously plus range indicated, battery condition and time) B. Large fonts (four data parameters displayed simultaneously).
<b>ENTER</b>	Used with the direction keys to change a setting or navigate the menus.
	Moves the cursor up or increments the entry marked by the cursor.
	Moves the cursor down or decrements the entry marked by the cursor.
	Moves the cursor to the left
	Moves the cursor to the right
<b>POWER</b>	Turns analyzer and conditioning system on and off.

## CHAPTER 3

---

### BASIC INSTRUMENT OPERATION

It is possible to master the basic operation of the instrument in a few minutes by following the procedure outlined below. Please refer to the other sections of this manual for a description of the more advanced features.

The Model 700 micro-emissions analyzers consist of two major components, the probe (whose function is to extract, clean, and dry the sample) and the main unit, which does the analysis and computations.

To operate the instrument follow the steps outlined below.

1. Remove the instrument from its case, attach the sample conditioning system supplied with your analyzer and turn the instrument on.
2. The instrument pump will immediately turn on and the ENERAC logo will appear.
3. If you are using the analyzer for the first time, press the **SETUP** key to set the appropriate parameters (i.e. fuel, units, etc.) for your application.

▶APR 1 '08 12:45:00
Fuel: Natural Gas
Temperature Units: F
Measure Units: PPM
Oxygen Ref: TRUE
Pumps:OFF Duty:50%
Cooler Duty:70%
Thermal Eff:0.30
Display Contrast:26
Version: 2.0
Battery: x.xx V

4. Use the “direction” keys and then the **ENTER** key to change your selection.
5. Press the **DISPLAY DATA** key and check the unit’s battery condition.

EFF:xx.x%	CO: xxxxxPPM
ST: xxxxx°F	NOx: xxxxxPPM
OXY:xx.x%	NO: xxxxxPPM
HC: xxxxxxPPM	NO2: xxxPPM
CO2:xx.x%	SO2: xxxPPM
AIR:xx.x%	DFT:xx.x"
HIGH RANGE  12:45:00	

The **DISPLAY DATA** key toggles between a small font and a large font screen. Select the small font screen.

The battery icon is displayed in the middle of the bottom line of the display. Its condition is marked by the shaded fraction of the icon. If the unit is powered by the battery charge a small “plug” icon will replace the battery icon.

**NOTE: Depending on the options enabled for your analyzer some of the entries in one or more of the displays shown above will be blank if that option is not available.**

NOTE: When connecting the battery charger to the analyzer make sure that the “plug” icon appears on the **DISPLAY DATA** screen. This ensures a proper power connection and charging of the batteries.



6. After making sure that the analyzer is drawing clean air at room temperature sample, press the **ZERO/SPAN** key. The cursor (reverse color) will point to the line:

Zero all sensors

Press the **ENTER** key to execute an auto zero cycle of all the sensors.

7. Following the end of the autozero period, press the **DISPLAY DATA** key. All sensors should indicate zero reading with the exception of the oxygen sensor that should read 20.9% (the concentration of ambient air) and the stack temperature that should correspond approximately to the room temperature.

8. Insert the analyzer’s probe into the stack or engine exhaust. Use the **DISPLAY DATA** key to read the stack parameters.

9. To obtain a printout of the data displayed, press the **PRINT** key. The cursor (reverse color) will point to:

Print Test Record

Press the **ENTER** key to execute a printout on the ENERAC’S printer.

10. When you are finished with your measurements, withdraw the probe from the stack, allow the analyzer to draw ambient air for a minute and for the probe to cool down, before packing the analyzer in its carrying case.



## CHAPTER 4

---

### POWER REQUIREMENTS

The Model 700 is supplied in either one of two power options: Standard or Heavy-Duty.

A. STANDARD OPTION. Power is supplied by 4 “D” size NiMh rechargeable batteries. Also standard “alkaline” “D” batteries can be used to operate the instrument. A 120 –240 Volt AC charger having a 12 Volt DC/ 1.5 A. output is supplied with the instrument. The battery charger will charge the 8,000 AH batteries in about six hours.

B. HEAVY DUTY OPTION. This option is required for analyzers that are supplied with “PERMEATION DRIERS”. Power is supplied by 6 “D” size NiMh rechargeable batteries. Also standard “alkaline” “D” batteries can be used to operate the instrument. A 120 –240 Volt AC charger having a 12 Volt DC/ 5 A. output is supplied with the instrument. The battery charger will charge the 8,000 AH batteries in about six hours.

***NOTE: Non-rechargeable batteries may explode or leak if the AC adapter or another battery charger is accidentally connected! If you are using alkaline (non-rechargeable) batteries, be sure to disable the AC charger connection by toggling the DC CHARGE SWITCH, located next to the batteries, to the position marked ‘Alkaline’. See the figure at the end of the manual***

Battery life is approximately 6-8 hours of continuous operation.

You can check the condition of the batteries at any time:

1. By pressing the DISPLAY DATA key, (small font screen) and observing the battery icon, located at the bottom of the display, in the middle, or
2. By pressing the SETUP key and observing the actual battery voltage, displayed on the last line. When the unit is operating on its batteries, the voltage displayed will vary from an initial 5.2–5.4 volts (fully charged) dropping slowly to 4.2-4.0 volts (batteries nearly empty). When the battery voltage drops to 4 volts a “battery low” warning will appear on the display. A few minutes later the instrument will automatically turn off, to preserve the remaining battery power for the sensor biases.



## CHAPTER 5

### SAMPLE FLOW & SAMPLE CONDITIONING SYSTEM

The ENERAC Model 700 can accommodate any one of the three available sample conditioning systems. These range from the simplest water trap and latex hose conditioning system, to the recommended Teflon/Viton hose and thermoelectric condenser system, to the most sophisticated Teflon/Viton and permeation Drier system. The last system requires the “heavy duty” power option.

The probe, shown below, is universal for all options and consists of a 3/8” OD Inconel 600 high temperature tubing of variable length (based on customer’s requirements). The tubing is threaded at the “stack” end to accept an optional sintered stainless steel filter. A type K inconel sheathed thermocouple is located inside the tube. Maximum continuous temperature for the probe is 2,000 °F.

#### 1. WATER TRAP – LATEX HOSE SYSTEM

This is the least expensive option available. It is recommended for measurements of engine exhausts using the NDIR (infrared) option, where loss of NO<sub>2</sub> and SO<sub>2</sub> is not important, since measurement of those gases is not typically required.

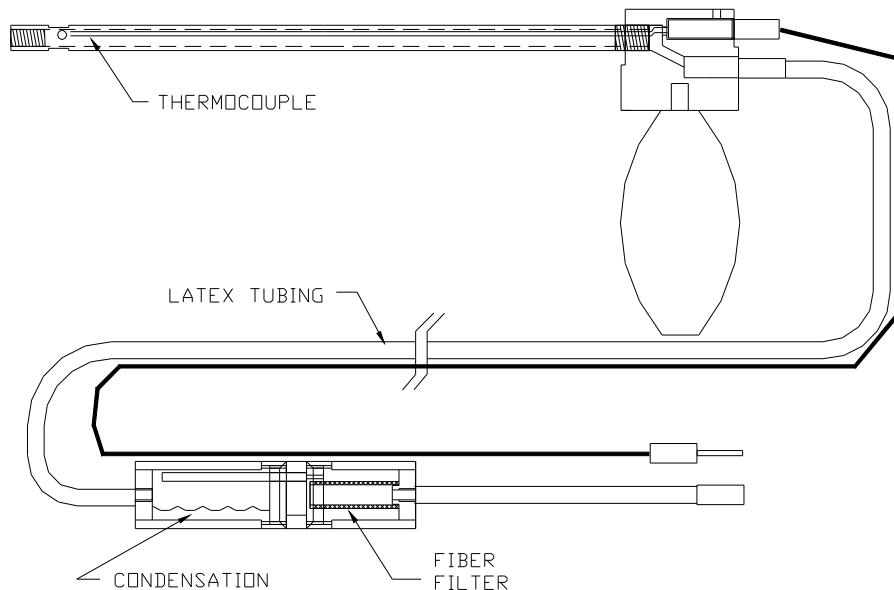

It is also recommended as a low cost option for combustion efficiency measurements. The water trap should be cleared of condensation after each use. The fiber filter should be replaced when it becomes noticeably discolored.

## 2. THERMOELECTRIC CONDENSER AND TEFLON/VITON HOSE

This is the standard option for the Model 700. It is recommended for most applications where condensation removal without significant loss of the NO<sub>2</sub> and SO<sub>2</sub> fraction of the sample is required.

The thermoelectrically cooled condensation trap, better known as “Peltier Drier”, is an optional accessory device for the Model 700 combustion–emissions analyzer.

NO<sub>2</sub> and SO<sub>2</sub> are gases that are highly soluble in water. The exhaust sample contains typically between 5% and 20% of water vapor, most of which will condense in the probe and sample line.

To prevent significant loss of NO<sub>2</sub> and SO<sub>2</sub> during transport of the sample from the probe to the analyzer, the following conditions must be satisfied:

1. Rapid sample transport. This is accomplished by maintaining a high flow rate using a relatively small diameter sampling line.
2. Use of a sample line made from a highly hydrophobic material. A Teflon sample line limited to 15 ft. long is best.
3. Minimum contact of the gas sample with the water collection mechanism and also no additional condensation occurring following the Peltier drier. This is accomplished by using a specially designed Peltier cooled manifold to separate the gas from the water.

The Peltier drier requires electrical power for operation. This is available from the analyzer through the dedicated electrical connector for the drier. Operation of the Peltier condenser will reduce the analyzer’s battery life. It is therefore recommended, but not necessary, to use the battery charger for longer operation.

The Peltier drier will maintain the sample at a certain temperature below ambient temperature to ensure no further condensation inside the analyzer. You can control this temperature differential by adjusting the COOLER DUTY CYCLE, if necessary.

The following table shows the approximate relation between duty cycle and temperature differential:

DUTY CYCLE	SAMPLE TEMP AMBIENT TEMP (°F)*
50%	-9
75%	-13
100%	-16

\*At 75° F ambient.

The duty cycle of the thermoelectric cooler is set at the factory to 70% and can be adjusted as follows

1. Press the **SETUP** key. The **SETUP MENU** will be displayed.
2. Press the **UP/DOWN** keys until the cursor points to **COOLER DUTY**.
3. Press the **ENTER** key.
4. Use the **UP/DOWN** keys to set the Peltier duty cycle. A minimum of 50% is recommended.
5. Press the **ENTER** key.

The condensation trap will fill with water after 2 to 4 hours depending on the fuel used. To empty the condensation trap simply disconnect it from the manifold by unscrewing it. When replacing it, be careful to seat the O-ring properly.

The following outline drawing illustrates the drier's operation.

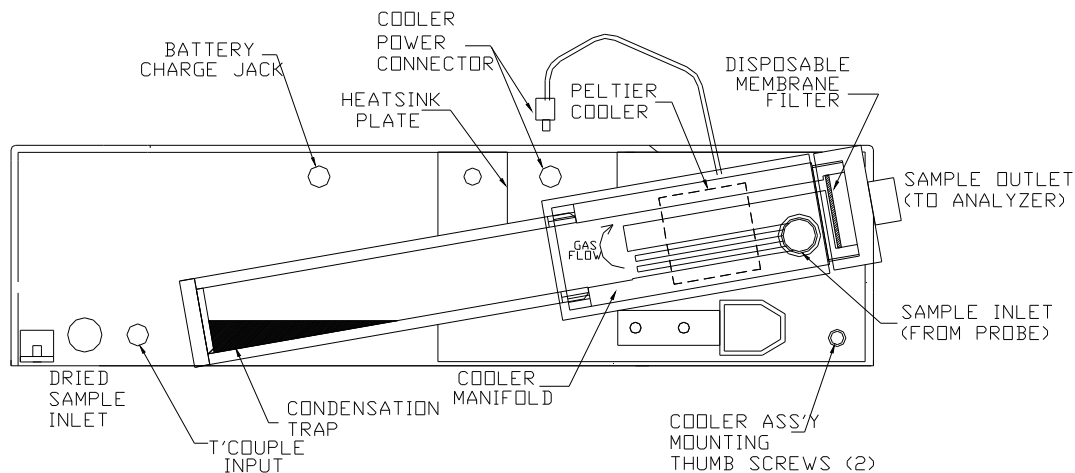

The sample consisting of gas and partially condensed water vapor enters the drier through the “SAMPLE INLET”. It flows through multiple narrow thermoelectrically cooled passages, where total separation of gas and vapor occurs. The dried sample makes a 180 degree turn, flowing upwards and goes through a membrane filter exiting through the “SAMPLE OUTLET”. The purpose of the membrane filter is to remove any particles and also to prevent flow of condensate into the analyzer by accidentally tilting the unit downwards.

The membrane filter is disposable and can be easily replaced by unscrewing the plastic white bushing. To maintain proper operation the analyzer should be mounted either in a horizontal or vertical position.

The peltier drier should also be used when the water vapor concentration of the sample exceeds 20% (the maximum capacity of the permeation drier).

### 3. PERMEATION DRIER CONDITIONING SYSTEM

This is a unique and proprietary conditioning system developed by ENERAC and used in its previous Model 3000E series of emissions analyzers.

It has the major advantage of removing all excess water vapor from the sample without allowing any condensation to take place. It is the best conditioning system for continuous and uninterrupted measurements.

This system draws more power than any other conditioning system and requires the “heavy duty” power option (6 batteries).

The probe assembly consists of an inconel probe, the main probe housing and a standard 10' length of hose and electrical cable.

## A. The inconel probe

The inconel probe is a five-piece assembly of metal tubing. It consists of the following parts.

**The gas extraction probe.** This is a 3/8" diameter piece of inconel tubing that is threaded to the probe housing. The instrument thermocouple is located inside this tube. A 13" piece of extension inconel tubing to be used with stacks having a diameter larger than 24". The extension tubing screws on the above piece to increase the effective probe length to 24". The Figure below shows the various components of the probe.

**A 1" long, 10 micron, sintered Hastelloy X filter.** The purpose of the filter is to block soot particles from entering the probe housing. The filter is reusable to a certain extent and can be cleaned a few times in a detergent and by blowing air from inside out. A light located on the probe housing monitors the condition of the filter. Maximum filter temperature is 1900 degrees F.

***You must never operate the instrument without the sintered filter.  
Such operation will damage the probe.***

**A 1/2" diameter soot particle deflector.** The purpose of the deflector is to create a flow stream for the soot particles around the filter and thus prolong its life. (Probes equipped with the S-V pitot tube for velocity measurements do not use this deflector!)

**A support bracket.** The purpose of the bracket is to support the probe assembly so that it can be mounted on the stack wall. Mount the probe at a distance from the stack wall that will not exceed the housing's maximum temperature of 160 °F, but not so far as to cause condensation inside the inconel tubing. The exposed part of the inconel tube should remain at a temperature that appears too hot to the touch in order to prevent condensation.

**Heat shield and adaptor (optional).** This aluminum shield is intended to protect the probe housing from any very hot stack gases escaping from the opening in the stack wall (typical in engine applications). To use the shield, slide it over the probe placing it as close to the probe housing as possible. Secure it by tightening the set-screw. To use the adaptor that comes with the shield, you should have a female 3/4 PT fitting mounted on the stack wall. The purpose of the adaptor is to seal the opening and support the probe assembly.

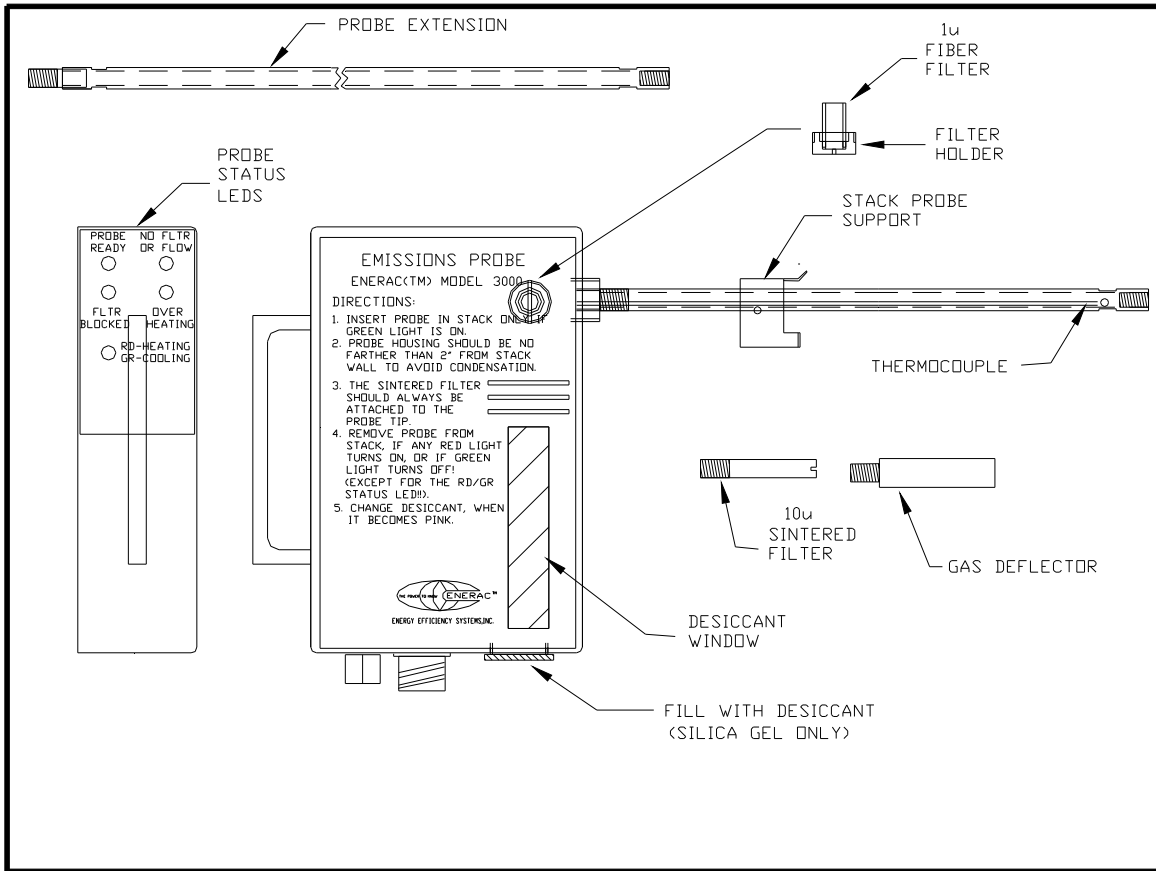

### A'. The stack-velocity (S-V) probe. (OPTIONAL)

If the ENERAC is equipped with (S-V) type of probe option, the section of the ENERAC's probe that is inserted in the stack consists of three sections.

***You must never operate the instrument without the sintered filter. Such operation will damage the probe.***

**The S type Pitot tube.** It consists of two pieces of 3/16" diameter stainless steel tubing with the tips open and bent at a certain angle according to the EPA specifications of 40CFR60 Appendix A, Method 2 for measuring stack gas velocities. The Pitot tube must always be oriented with the open tips parallel to the direction of the stack gas flow. Care must be taken to keep the tubes from getting clogged by soot particles. The end of the Pitot tube assembly is connected by means of two flexible hoses to a very accurate low pressure transducer located inside the probe case.



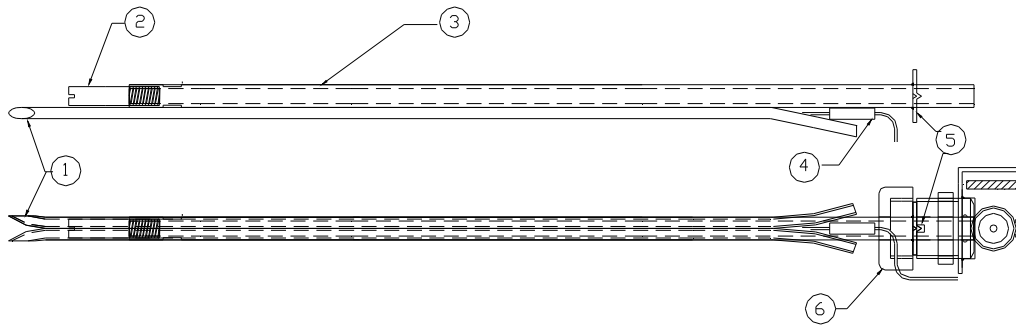

- ① S type pitot tube
- ② Hastelloy sintered filter
- ③ Inconel sampling tube
- ④ Inconel sheathed thermocouple end
- ⑤ Pitot tube orienting notch
- ⑥ Probe retaining cap

The Pitot tube is welded to the gas extraction tube. Two pieces of flexible high temperature Viton hose connect the Pitot tube to the low-pressure sensor located inside the probe case. The type K inconel sheathed thermocouple, having a length approximately equal to the length of the gas extraction tube, fits snugly in the space between the Pitot tube and the gas extraction tube. The thermocouple is connected to a flexible thermocouple wire that terminates to a quick disconnect. During measurement move the thermocouple tip slightly, so that it is not in contact with the pitot tube. The whole probe assembly can be detached from the probe case and stored elsewhere. This makes it possible to use interchangeable probes of different lengths using the same instrument and probe case.

## B. The probe housing

The probe housing consists of a rectangular aluminum box whose external dimensions are the same for both the standard probe and the S-V velocity probe assembly. The similarity, however, ends there. The S-V velocity probe utilizes an embedded microcontroller that checks the operation of the probe, analyzes temperature and velocity information, and communicates with the main section of the analyzer through its serial port.

The probe housing contains a permeation type drier, whose function is to remove the excess water vapor that is present in the sample and thus, prevent condensation of moisture in the hose assembly. It also houses a secondary fiber filter for added protection.

Nitrogen dioxide and to a lesser extent sulfur dioxide react readily in water and any condensation present in the hose assembly would result in erroneous readings.

The probe housing consists of the following components

- a. **The secondary fiber filter.** This is a small cylindrical 0.5 micron glass fiber filter for the removal of the finer particles from the gas stream. It is accessed from the side of the probe (see figure above). This filter should be replaced periodically.
- b. **The permeation drier assembly.** This assembly consists of the permeation drier, a support manifold for the heated probe and a pump that supplies the counterflow air to the drier. The drier is designed to reduce samples containing as much as 20% water vapor to a dew point of 50 °F, or lower. The drier assembly is located inside the probe housing, with the exception of a small piece of clear tubing that is located just outside the probe.
- c. **The clear tubing.** The piece of clear tubing located at the end of the probe functions as a monitor to check for moisture condensing on the walls of the hose. If you observe condensation, you must reduce the sample pump flow rate. The nominal flow rate for the extracted sample is 550 cc/min at room temperature. The flow rate will be slightly reduced, when the probe is inserted in the stack, because the heated sintered filter's resistance to flow will be increased.

If you observe some condensation during your measurement and wish to reduce the sample flow rate, proceed as follows:

- a. Connect the calibration accessory flow meter to the tip of the probe in such a way as to monitor the instrument flow rate. Record this flow rate.
- b. Press the **SETUP** key and use the **DOWN** key until the cursor points to:  
Pump SAMPLE Duty: XX%
- c. Press the **ENTER** key.
- d. Use the **UP/DOWN** keys to reduce the duty cycle of the sample pump while observing the flow rate on the flow meter.
- e. Do not reduce the flow rate below 500 cc/min.

2. **The desiccant drier.** A small quantity of silica gel desiccant is stored inside the probe housing. The purpose of this desiccant is to dry the counter flow air that is introduced into the permeation drier and thus increase the capacity of the permeation drier. There is a small window on the face of the probe housing to check the condition of the desiccant. The desiccant must be replaced when it changes color to pink-white. You can access the desiccant through the threaded plug located at the bottom of the probe housing.

**3. The LED assembly.** There are five LEDs mounted on the back of the probe assembly. One is green, three are red, and the fifth is a bicolor red/green LED that is used for diagnostic purposes.

*NOTE (S-V velocity probe): Each time the instrument is turned on or the probe is connected to the analyzer, the four LEDs will turn ON and OFF in sequence to indicate proper initialization of the probe electronics.*

During a measurement, you should monitor the LEDs on a periodic basis to make sure that the probe is functioning properly.

***REMOVE THE PROBE FROM THE STACK AT ONCE,  
IF THE "OVERHEATING " LED TURNS ON!***

The “**PROBE READY**” GREEN LED monitors the temperature at the drier inlet to make sure that it is sufficiently high to prevent condensation of the sample.

**Insert the probe in the stack, only if this LED is on!** It takes approximately 2-4 minutes for this LED to turn on after a cold start, if the ambient temperature is 65 °F or higher. It may take 10 minutes, if the ambient temperature drops to 40 °F. It may take even longer, if the unit is operated on batteries.

The “**FLOW BLOCKED**” RED LED monitors the status of the sintered Hastelloy filter, that is located at the tip of the probe. It also monitors the status of the fiber filter located inside the probe manifold. When either filter becomes excessively dirty and requires cleaning or replacement, this light will turn on.

As the sintered filter is heated in the stack, the pressure drop across the filter will increase from a room temperature pressure drop of 3" to a maximum of 20" W.C. at 1800 °F. The instrument pump is capable of pulling a sample with a negative pressure of at least 40". The pressure switch that activates the LED is set for 30" W.C..

The “**NO FILTER OR FLOW**” RED LED is a check against any blockage or kinks in the hose or inside the permeation drier. This light will also turn on , if the sample pump is turned off by means of a suitable command, *OR IF THERE IS NO FILTER AT THE TIP OF THE PROBE.*

*If the pressure in the stack exceeds +4" W.C., the "NO FILTER OR FLOW" LED will turn on. You should ignore this LED and proceed with your measurements! This is common in engine measurements, when the ENERAC probe is located in front of a catalytic converter.*

The “**OVERHEATING**” RED LED monitors the temperature at the drier inlet to make sure it does not exceed the maximum permissible temperature that the drier can withstand. *For this reason, you must remove the probe from the stack at once, if this light turns on!*

The “**THE HEATING/COOLING**” bicolor LED monitors the status of the thermoelectric element and is used for diagnostic purposes, only. When the instrument is turned on, this LED should always be ON (i.e. RED). When the unit is warmed up this LED will be cycling every few minutes alternating between ON-RED and OFF. Once the probe is inserted in the stack its status will depend on the temperature of the drier manifold. If this temperature becomes high, the LED will turn GREEN, indicating that the ENERAC heat pump has switched to cooling the manifold.

### **C. The hose assembly**

The hose assembly consists of a 10 ft. long or longer Viton hose and a power extension cable of the same length. In addition, there is a yellow thermocouple extension cable for the standard probe, or a twisted pair (serial communication cable) for the S-V velocity probe. There are also special gas and electrical connectors. Viton is the material of choice for the hose, because of its inertness and high flexibility.

*NOTE: If the instrument is exposed to the sun or is operating for a long time, the ambient temperature indicated may rise a little higher than the room temperature. This does not affect the accuracy of the stack temperature measurement.*

## CHAPTER 6

---

### SENSORS

The great versatility of the Model 700 Emissions system is partly due to the large number of sensors available within a single analyzer.

These sensors are primarily gas sensors and can be grouped into three categories based on their principle of operation:

1. Electrochemical (SEM) sensors.
2. NDIR (infrared sensors)
3. Non gas sensors (temperature & draft sensors)

#### 1. ELECTROCHEMICAL SEM™ SENSORS

The Model 700 ENERAC employs proprietary SEM sensors specifically designed for the harsh environmental conditions expected during stack and engine emissions measurements.

The SEM sensors are distinguished by their design. Each sensor consists of two components: the sensor module and the precision control module (PCM). The function of the PCM is to set the sensitivity of the sensor and also to contain any filter material that removes the effect of interfering gases.

These sensors have additional electrode and/or temperature control systems that are not found in any other electrochemical sensors.

By means of an accurate dilution control system, the sensors are capable of measuring both low and high gas concentrations.

*PCMs are designed to fit only on top of their respective sensors, only! (i.e. a CO PCM will not fit on an NO or SO2 sensor!*

These sensors measure the following emission gases:

## A. Carbon monoxide

This is a four electrode sensor that measures simultaneously both the carbon monoxide and the interfering hydrogen concentration. The ENERAC subtracts the hydrogen interference for an accurate CO measurement.

The carbon monoxide sensor is supplied with either a standard PCM for a 2,000 PPM range, or a high sensitivity PCM for a 500 PPM range. Its life is typically 2 years.

## B. Nitric oxide sensor (NO sensor)

This is a proprietary four electrode sealed electrochemical cell. It consists of two sections. One section houses the sensor elements and a temperature sensor.

The other section is the interchangeable Precision Control Module made of aluminum. The sensor section contains a proprietary design consisting of four electrodes made of exclusively noble metals immersed in an electrolyte. Nitric oxide gas diffuses through the tiny capillaries located on the face of the PCM and through the filter media. It reacts with oxygen present inside the cell to form nitrogen pentoxide. The reaction produces an electric current proportional to the concentration of the gas. Sensor life is estimated at 2 years.

The sensor and PCM module temperature is controlled by a thermoelectric Peltier element located between the sensor and the aluminum manifold. Its function is to maintain the sensor temperature below 25 degrees Celsius in order to limit unpredictable temperature-based base-line drifts in accordance with the EPA CTM-022 protocol requirements.

The SEM<sup>TM</sup> NO sensor of the ENERAC Model 700 is superior to the typical electrochemical type sensor in accuracy, interference rejection, and its design for continuous operation.

Its inboard disposable filter has an estimated life in excess of 100,000 PPM-hours against sulfur dioxide.

This sensor requires a constant bias voltage for proper operation. This voltage is supplied to the sensor, even when the instrument is turned off. It draws a small amount of current and will drain the batteries completely in about 10 months. For this reason the unit should always be given a fresh charge once every 2-3 months.

## C. Nitrogen dioxide sensor (NO<sub>2</sub> sensor)

This is an electrochemical cell with its PCM an integral part of the sensor assembly. There is no Precision Control Module or interference rejection filter media for it. It has a standard range of 0 to 500 PPM. Its life is estimated at two years.

#### D. Sulfur dioxide sensor (SO<sub>2</sub> sensor)

This is an electrochemical cell consisting of two sections also. One section consists of the sensor module that houses the electrodes and electrolyte. The other section consists of the Precision Control Module. A breakthrough in the sensor design eliminates interference from NO<sub>2</sub> gas.

The SEM<sup>TM</sup> SO<sub>2</sub> sensor of the ENERAC model 3000E is fabricated in a different manner from the typical electrochemical type sensor and is superior in accuracy, interference rejection and its design for continuous operation.

This sensor also requires a constant bias voltage for proper operation. This voltage is supplied to the sensor, even when the instrument is turned off. It draws a small amount of current and will drain the batteries completely in about 10 months. For this reason the unit should always be given a fresh charge once every 2-3 months.

#### E. Oxygen sensor (O<sub>2</sub> sensor)

This is a two-electrode electrochemical cell. It has a silver cathode and a lead anode. Oxygen diffuses through a tiny hole and reacts with the lead anode. The reaction produces an electric current. The unit software linearizes the current vs. oxygen response. The cell becomes exhausted when all the lead is consumed. It takes about two years for this to happen.

### DUAL RANGE OPTION FOR ELECTROCHEMICAL SENSORS

Electrochemical sensors typically have a range which is limited to at most three orders of magnitude. Thus typically sensors with a range of 2,000 PPM should not even be exposed to higher concentrations, since one of the weaknesses of these sensors is saturation and erroneous readings, if exposed to higher concentrations.

A number of applications, however, require the need for measuring both low and high gas concentrations as is the case of measurements upstream and downstream of a catalyst.

The ENERAC 700 uses a second pump to draw dilution air that enables the analyzer to extend the range of the sensors by a factor of at least 4, and also provide purging of the sensors as required by the EPA CTM-034 method.

To obtain an accurate high range reading the ENERAC 700 uses an additional calibrated oxygen sensor. By combining the reading of the sample oxygen sensor and the dilution oxygen sensor an accurate calculation of the gas concentration for the high range is obtained. The figure below shows an outline of the sensor configuration.

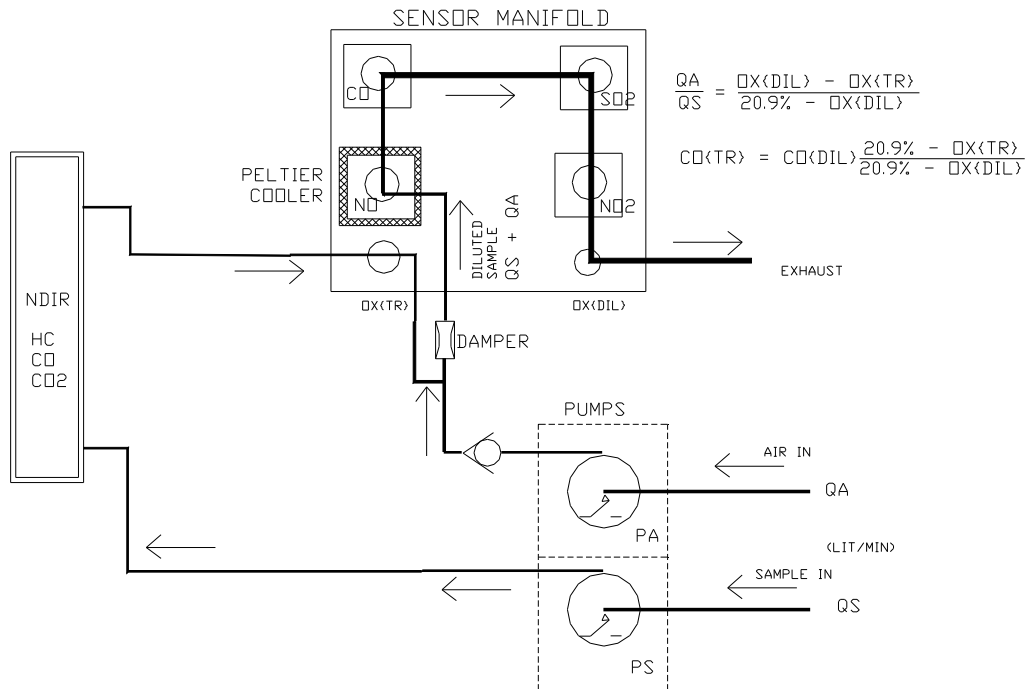

Typically the air pump has a flow rate of approximately 2,000 cc/min. The flow rate of the sample pump can be adjusted from 2,000 cc/min to 400 cc/min by reducing its duty cycle. The two oxygen sensors monitor the respective concentration of oxygen and the processor calculates the dilution ratio.

When the analyzer operates in its low range, only the sample pump is on. When the analyzer operates in its high range both pumps are on. The duty cycle for the sample pump is automatically reduced and typically set at the factory. In the purge mode, only the air pump is on.

The optional NDIR sensor bench is not affected by the setting of the analyzer range, as shown in the figure.

## 2. NDIR (INFRARED) SENSORS

The Model 700 emissions analyzer can be equipped with infrared sensor measurement capability for the measurement of three gases: carbon monoxide, carbon dioxide and hydrocarbons.



The infrared option has the following specifications:

GAS	RANGE	ACCURACY
CARBON MONOXIDE	0% - 10%	3% relative
	10% - 15%	5% relative
CARBON DIOXIDE	0% - 16%	3% relative
	16% - 20%	5% relative
HYDROCARBONS AS PROPANE	0 - 2000 PPM	4 PPM or 3% relative
	2000 - 10,000 PPM	5% relative
	10,000 - 30,000 PPM	8% relative

NDIR (non-dispersive infrared spectroscopy) relies on the way different gases absorb infrared radiation at varying frequencies, depending on the particular gas. The amount of radiation absorbed is used to calculate the concentration of the gas based on the Beer's Law.

The figure below shows an outline of the NDIR assembly.

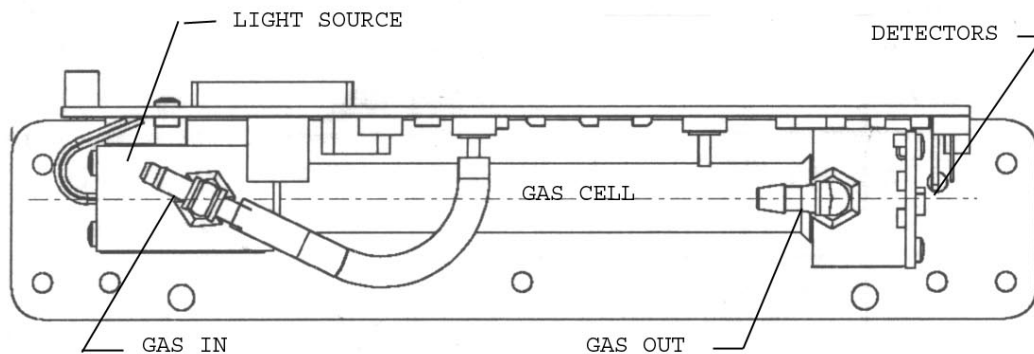

The light source is a pulsed micro bulb. There are four detectors: one for each gas plus a reference detector. The detectors consist of pyroelectric elements equipped with narrow-band transmission filters, each filter tuned to the absorption band of the target gas.

Life for the device is in excess of 5,000 hours, but care must be taken to prevent soot or water from entering the gas cell. It is possible in principle to clean the gas cell, but it is a costly and time-consuming operation.

***NOTE: If the ENERAC is equipped with the NDIR option, the analyzer will enter an autozero countdown each time it is turned on. Consequently, you must not turn the analyzer on if its probe is mounted on a stack or engine exhaust.***

The NDIR bench is designed for operation primarily with measurements of engine exhausts, according to the California BAR 97 regulations.

The hydrocarbons sensor is tuned to the absorption band of propane. However, it will respond to other hydrocarbons with different sensitivity.

### 3. NON-GAS SENSORS

#### A. Ambient temperature sensor

This is an IC sensor located near the cold junction of the thermocouple. The ambient temperature is displayed on the ZERO/SPAN screen and is used for temperature compensation.

#### B. Stack temperature sensor

The thermocouple is located at the tip of the probe. It measures the stack temperature minus the ambient temperature. The thermocouple junction is a shielded, ungrounded, inconel sheathed, type K thermocouple with a capability of measuring temperatures from 0 to 2000 °F. The instrument software linearizes the thermocouple output to improve the accuracy.

#### C. NO temperature control sensor

This is an IC sensor located inside the SEM NO sensor. Its purpose is to monitor the NO sensor temperature and control it to below 25 °C to prevent zero drifts.

#### D. Draft sensor

This is a piezoelectric sensor located inside the analyzer. Because of the pressure drop caused by sample flow through the sampling line and filters, the sensor zeroes itself every time an autozero is carried out. Consequently, you must not allow the filter to get clogged with soot as this would give an erroneous reading. For accurate draft measurements irrespective of filter condition, you must request a sampling line with an extra piece of tubing for draft measurements.



## CHAPTER 7

---

### ANALYZER SETUP

The SETUP MENU allows the operator to change system parameters.

▶APR 1 '05 12:45:00
Fuel: Natural Gas
Temperature Units: F
Measure Units: PPM
OxygenReference:TRUE
Pumps:SAMPLEDuty:90%
Cooler Duty:50%
Thermal Eff:0.30
Display Contrast:26
Version: 1.0
Battery: x.xx V

Every parameter listed on the SYSTEM MENU screen can be changed as follows.

- a. Use the **UP / DOWN** keys to move the arrow (▶) to the parameter you wish to change.
- b. Press **ENTER** to edit the value. The arrow will disappear as the current line shifts to the left by one character and a cursor appears over the value. This indicates that you are in edit mode.
- c. Use the **UP / DOWN** keys (buttons displaying the triangles) until the desired value of the selected parameter appears on the display.
- d. Press the **ENTER** key to execute the change.

A more detailed explanation of each parameter follows:

- 1) **DATE & TIME:** The analyzer's internal clock is displayed in the format month-day-year, hour:minute:second. Hours are always displayed using a 24 hour clock.
- 2) **FUEL:** The analyzer has the following fifteen fuels stored in its memory
  - (1) #2 OIL
  - (2) #6 OIL
  - (3) NATURAL GAS
  - (4) ANTHRACITE (COAL)

- (5) BITUMINOUS (COAL)
- (6) LIGNITE (COAL)
- (7) WOOD, 50% MOISTURE
- (8) WOOD, 0% MOISTURE
- (9) #4 OIL
- (10) KEROSENE
- (11) PROPANE
- (12) BUTANE
- (13) COKE OVEN GAS
- (14) BLAST FURNACE
- (15) SEWER GAS

To select the desired fuel, press the **UP / DOWN** keys until the desired fuel appears on the top of the display and then press **ENTER**. The fuel selection affects the following parameters: combustion efficiency, carbon dioxide calculation and display of toxic gases in units other than PPM.

- 3) TEMPERATURE UNITS: The **UP / DOWN** keys toggle between °F (Fahrenheit) and °C (Celsius). Stack temperature and ambient temperature will be displayed, printed, and saved in the selected units.
- 4) MEASURE UNITS: When the cursor is blinking on this line, you can select any of the following units of measurement for the toxic gases (CO, NO, NO<sub>2</sub> & SO<sub>2</sub>):
  - PPM : Parts per million (volumetric)
  - MGM : Milligrams per cubic meter
  - #/B : Lbs. (of pollutant) per million BTU of fuel
  - GBH: Grams (of pollutant) per brake horsepower-hour

To choose the desired emission units, toggle the **UP / DOWN** buttons until the proper units are displayed. Then press the **ENTER** key. If you select GBH (grams/brake horsepower-hour) as the desired units, you must not forget to set the value of the (engine) thermal efficiency also! You can obtain this figure from the engine's manufacturer specifications. It differs somewhat as a function of engine type and load factor. (Typically, it is a number between 0.25 and 0.35) The ENERAC's default value is 0.30. If the thermal efficiency is not known, it may be computed by using the engine's BSFC (brake-specific fuel consumption-BTU/BHP-HR) as follows:

$$\text{ENGINE EFFICIENCY} = 2547/\text{BSFC}$$

*NOTE: Emission units measurements in PPM, MGM, #/B and GBH are carried out on a dry basis as required by the EPA's 40CFR75 . (The ENERAC is an*

*extractive analyzer, whose conditioning system removes most of the water vapor before the sample reaches the sensors).*

*NOTE: Values of emissions in #/B and GBH are fuel and CO<sub>2</sub> dependent. The fuel parameters for certain typical fuels (i.e. the F- factors for anthracite, etc.) used in the analyzer have been modified to be identical to those specified in 40CFR60 Appendix A method 19 of the code of federal regulations. Consult ENERAC, Inc., for details and correction factors.*

***NOTE: NO and NO<sub>x</sub> emissions in #/B or GBH are computed as NO<sub>2</sub>!***

- 5) OXYGEN REFERENCE: Many environmental regulations require that the concentrations of pollutants measured, be corrected to some reference value of oxygen other than the actual concentration at the time of the measurement. Typical oxygen reference values are 0% (air free), 3%, 7% or 15%. To select the desired oxygen reference value, press the **SHIFT** key repeatedly until the blinking cursor is located on the OXYG REFERENCE line on the display, as described above. Toggle the **UP / DOWN** buttons, until the desired value of the reference oxygen is displayed. (Range is 0-20% in 1% increments). Then press the **ENTER** key. To return to uncorrected measurements, press the **UP** button until the display reads:

OXYGEN REFERENCE: TRUE.

*NOTE: Setting the OXYGEN REFERENCE to a value other than TRUE affects values of emissions concentrations in PPM and MGM. It does not affect values in #/B or GBH!*

- 6) PUMP: Pump status, on or off, is displayed, followed by the duty cycle of the pump. The duty cycle can be set with the **UP / DOWN & ENTER** keys.
- 7) COOLER DUTY: This setting is for the optional thermoelectric cooler. See CHAPTER 5.
- 8) THERMAL EFF: Selects the thermal efficiency of the engine. See MEAS. UNITS above.
- 9) DISPLAY CONTRAST: Select the best value for viewing the LCD screen.
- 10) VELOCITY UNITS: (Velocity Option) Select between feet per second (FPS) and cubic feet per minute (CFM)
- 11) STACK SIZE: (Velocity Option)

## CHAPTER 8

---

### INTERNAL DATA STORAGE

The STORE MENU allows the operator to store data and manage the internal storage buffers.

```
►Store Current Buffer
  Select Buffer...
  Start Periodic
  Select Interval: 1m
  Review Buffer...
  Name Buffers...
  Erase Buffer...
  -----
00: BUFFER#02
```

The ENERAC Model 700 has 100 internal storage buffers. Each buffer stores one complete set of emissions data. There are two ways to store emissions data to the ENERAC's buffer. You can either store data by selecting the option STORE CURRENT DATA after pressing the **STORE** key, or alternatively you can make use of the ENERAC's capability of storing data automatically on a periodic basis. You can set the time period between data storage. The STORAGE MENU shows the relevant display lines for the storage options.

1. **STORE CURRENT BUFFER:** The ENERAC will store one set of data into the buffer currently selected. The index number and the name of this buffer appears at the bottom of the screen.
2. **SELECT BUFFER:** Selecting this item will display an index of the ENERAC's 100 internal storage buffers. Buffers that are used have an icon next to their index number. The selected storage buffer is indicated by the reverse color line. When data is stored, this pointer will automatically advance to the next available buffer. If you want to store data in a different location, use the UP, DOWN, & ENTER keys to select a new buffer. As you scroll up and down, buffers containing data show their date and time at the bottom of the display. Empty buffers show the word *empty*.
3. **START PERIODIC:** This will turn on the periodic store function. In this mode, the unit will continuously store data at an interval displayed on the next line. Once enabled, this line will read: STOP PERIODIC.

4. **SELECT INTERVAL:** The time between each store is set here. This can range from 15 seconds to 60 minutes.
5. **REVIEW BUFFER:** This choice allows you to view previously saved data. Press **ENTER**. The display will switch to the data screen, with the data in the first buffer displayed. The time and date when the data was saved will appear at the bottom of the display. Use the **UP / DOWN** keys to scroll through the buffers.

6. **NAME BUFFERS:** This choice will take you to another screen where you can rename one or more buffers. This is useful if you use several buffers together to form a test series. Select the starting test index with the **UP / DOWN / LEFT / RIGHT** keys and press **ENTER**. Next, select the ending test index. The cursor will move to the first character of the first buffer's name, and the alphanumeric keyboard will appear. Use the **UP / DOWN / LEFT / RIGHT** keys to navigate around the keyboard, and press **ENTER** to select the letter or number. For lower-case letters, highlight *shift* and press **ENTER**, for symbols, highlight *sym* and press **ENTER**. The arrows in the corner will move the cursor forward or backward through the buffer's name.

*** NAME BUFFERS ***									
Starting Buffer: 00									
Ending Buffer: 00									
Name:xxxxxxxxxxxxxxxx									
1	2	3	4	5	6	7	8	9	0 ◀
A	B	C	D	E	F	G	H	sym	▶
I	J	K	L	M	N	O	P	shift	
Q	R	S	T	U	V	W	X	Y	Z

7. **ERASE BUFFER:** This option is used to erase stored. Data that has been stored in the analyzer's memory will be retained even after the instrument has been shut off and its batteries removed. To erase the contents of a specific buffer, use the **UP / DOWN** keys to move the arrow to the desired buffer. As you scroll up and down, buffers containing data show their date and time at the bottom of the display. Empty buffers show the word *empty*. If you wish to erase all 100 of the ENERAC's stored data, move the arrow to the entry *ALL BUFFERS* and press **ENTER**.



# CHAPTER 9

## INTERNAL PRINTER

The PRINT MENU allows the user to print test records.

```
►Print Test Record
  Start Test Log
    Log Interval:
  Print Buffer...
  Edit Header Info...
  Calibration Record
  Paper Feed On/Off
```

**PRINT TEST RECORD:** This option will print a test record of the current stack parameters.

**PRINT TEST LOG:** This option begins a log of the following combustion parameters: stack temperature, oxygen, carbon monoxide, excess air, and efficiency.

**LOG INTERVAL:** This selects the interval between each log entry. The interval can be set between 1 and 60 seconds.

**PRINT BUFFER:** This option is used to print data stored in the analyzer's memory. Each line corresponds to one storage buffer. Buffers containing data show an icon next to the index number. When you scroll up and down, the date (mm/dd) and time (hh/mm) when the data was stored appear at the bottom; empty buffers show the word "empty". To print the contents of a specific buffer, use the **UP / DOWN** keys to move the arrow to the desired buffer and press **ENTER**. If you wish to print all of the ENERAC's stored data in sequence, move the arrow to the entry **ALL BUFFERS** and press **ENTER**.

**EDIT HEADER INFO:** This will display a screen where you can change the information printed at the top of each printout. Usually the customer name appears here. To edit this information, use the **UP / DOWN / LEFT / RIGHT**

```
ENERAC
700
Serial #: 000000
Company Name
TEST RECORD

APR 1 '05 12:45:00

Fuel: Natural Gas

Effic: XX.X %
Amb Temp:XXX F
Stack T:XXXX F
Oxygen: XX.X %
CO: XXXX PPM
CO2: XX.X %
HC: XXXXX %
Draft: XX.X "
Ex.Air: XXX %
NO: XXXX PPM
NO2: XXXX PPM
NOX: XXXX PPM
SO2: XXXX PPM
Oxygen Reference:TRUE
```

```
ENERAC 700
Serial #: 000000
Company Name
TEST LOG

APR 1 '05 12:45:00
Fuel: Natural Gas

ST OXY CO AIR EFF
XXXX XX.X XXX XXX XX.X
XXXX XX.X XXX XXX XX.X
XXXX XX.X XXX XXX XX.X
. . . . .
F % PPM % %
Oxygen Reference:TRUE
```

keys to navigate around the keyboard, and press **ENTER** to select the letter or number. For lower-case letters, highlight `shift` and press **ENTER**, for symbols, highlight `sym` and press **ENTER**. The arrows in the corner will move the cursor forward or backward through the name.

**CALIBRATION RECORD:** This option will print a record of each sensor's last calibration, including the date of calibration and span gas value used.

**PAPER FEED:** This toggles the printer's motor on and off, advancing the paper out the top of the analyzer as needed. The motor will not turn if there is no paper present.

## CHAPTER 10

---

### CALIBRATION

Every instrument must occasionally be calibrated against some known value of a parameter in order to make sure that its accuracy has not deteriorated.

The instrument software makes sure that the display readout is always a linear function of the source excitation (i.e. gas concentration or temperature, etc.). You therefore need only two points on the straight line to calibrate a parameter over its entire range. Usually, the first point chosen is the zero value (called zeroing the instrument). The second point has to be set by using some known value of the parameter being calibrated (for example, using 200 PPM certified carbon monoxide gas to set the display to read 200). Sometimes the second point is not needed: if the slope of the parameter is known and is always the same. For example, for the stack temperature the slope of the curve is well known and you don't need a span calibration.

Traditionally, both zeroing and span (i.e. second point) calibration was done manually, by rotating suitable potentiometers until the display was set to read first zero in ambient air and then the correct value using span gas.

With the introduction of microprocessors, it became a simple matter for instruments to zero themselves automatically upon start up (autozero), however, this simplification requires caution. The instrument must be started in a true "zero" environment. Otherwise it will assume as "zero" non-zero conditions and give erroneous readings. **Never autozero the ENERAC, if the probe tip is still hot following a recent measurement.**

```
**** ZERO - SPAN ****
▶Zero All Sensors
  Amb Temp: 74 °F
  Zero Time: 60sec
  Span Time:120sec
  Span CO:  xxxx PPM
  Span H2:  xxxx PPM
  Span NO:  xxxx PPM
  Span NO2: xxxx PPM
  Span SO2: xxxx PPM
  Span CO-IR:xx.x %
  Span CO2:  xx.x %
  Span HC:  xxxxx PPM
  Span Draft: xx "
  Sensor History
```

The ENERAC carries out this improvement in automatic calibration procedure one step further. It does away with all potentiometric span adjustments. You just tell it the value of the calibrating parameter that you are using and the instrument adjusts itself automatically.

The SPAN MENU lets you set span calibration values for each sensor and performs all sensor calibrations. The SPAN MENU is shown below.

**ZERO ALL SENSORS:** This will set the zero point of CO, CO<sub>2</sub>, HC, NO, NO<sub>2</sub>, SO<sub>2</sub>, ST and DRAFT.

**AMB TEMPERATURE.** Press the **ENTER** key to adjust the ambient temperature reading. The display will show:

AMB T OFFSET: 0C

Use the **UP/DOWN** keys to set the value, in °C, to add or subtract to the measured ambient temperature.

**ZERO TIME:** If you wish to change the countdown time for autozeroing the analyzer, press the UP or DOWN keys accordingly, when the cursor is blinking on this line on the display. The autozero countdown should be at least 60 seconds. However, it need not be more than 120 seconds.

**SPAN TIME:** When carrying out a span calibration, you must introduce the span gas for an appropriate amount of time before the analyzer executes the span calibration. This setting, which is the same for all sensors, controls this time interval. The time is indicated in seconds, but a minimum of 5 minutes of span gas feeding is required for proper calibration.

**SPAN XXXX:** The remaining lines of the SPAN MENU are used for carrying out span calibrations of the CO, NO, NO<sub>2</sub>, SO<sub>2</sub>, NDIR, combustibles, and stack draft sensors. For detailed use of these settings, please refer to the chapter on calibration.

## **A. AUTOZEROING THE INSTRUMENT**

Every time you turn the instrument on, wait for two minutes to allow the ENERAC to warm up. To start the autozero procedure, press the **ZERO/SPAN** button and select **ZERO ALL SENSORS**.

At the end of the autozero period the ENERAC reads the output of all sensors and sets them all to zero, with the exception of the oxygen that it sets to 20.9%. (The ambient temperature is read directly). Consequently, it is very important that at the moment of "zeroing" the probe tip is at room temperature and the environment is clean from traces of carbon monoxide or other gases.

If you have the NDIR option, the ENERAC 700 will automatically start to autozero when the unit is turned on.

*NOTE: In practice AUTOZEROING is only needed once at the beginning of a day of measurements. The ENERAC will not have sufficient zero drift during the next 24 hours to require additional autozeroing procedures.*

To carry out the autozero procedure, follow these steps:

1. Connect the probe and water trap to the unit. Make sure the probe tip is at room temperature.
2. Turn the analyzer on. Make sure that the “battery low” message does not appear on the display.
3. Make sure that the analyzer pump is on. **(Always zero the instrument with the pump on, for flue stack measurements!)**
4. Press the **ZERO/SPAN** button. Press **ENTER** to confirm. Wait for the countdown to end.
5. If no error messages appear at the end of the countdown proceed with your measurements.

## **B. SPAN CALIBRATION**

You must always span calibrate the instrument every time you replace a sensor. At a minimum, once every 3-4 months you should perform a span calibration of the instrument. For greater accuracy you should check the calibration of the instrument before and after each emissions test. The parameters that require a span calibration are, depending on the available options: carbon monoxide, carbon dioxide, nitric oxide, nitrogen dioxide, sulfur dioxide, hydrocarbons, and draft.

You can carry out all span calibrations in sequence or just one, if you wish. You can use your own span gas, or if you need to calibrate the ENERAC in the field, you can use the convenient gas calibration kit supplied by ENERAC.

### **(A) Span calibration using the ENERAC kit**

The gas calibration system supplied by ENERAC is shown in Figure 2. The kit comes with a gas cylinder containing a mixture of 200 PPM carbon monoxide (typically), with balance nitrogen. For NO, NO<sub>2</sub> and SO<sub>2</sub> calibrations you must order extra gas cylinders containing the desired type of span gas. All four gas cylinders and calibration apparatus fit inside a carrying case for easy transportation to the field.

Span calibration using the ENERAC calibration kit is easy. You don't need to worry about gas flow rates and there is no wasting of calibration gas. Follow the instructions supplied with the calibration kit.

### **(B) Span calibration using your own gas**

If you wish to use your own gas to perform span calibrations you must take certain precautions in order to calibrate the sensors properly.

Notice that you will need a number of certified gas cylinders. Make sure that you use a bypass flow meter as shown in order to supply an adequate flow of span gas without developing excessive pressure on the sensors. The accessory ensures proper gas flow to the ENERAC.

*For greatest accuracy it is recommended that you use a span gas value close to the emission concentration you expect to measure.*

Set up your calibration apparatus as shown in the figure below.

*You must not feed gas to the ENERAC under pressure and you must not starve the ENERAC's pump for gas. When feeding the gas to the ENERAC you must maintain a reasonably constant pressure. This is a requirement of all diffusion-type sensors.*

Connect the calibration accessory to the ENERAC probe. Make sure the rubber bulb is inserted past the square grooves located at the probe tip. Connect the other end of the calibration accessory to the gas cylinder.

*Make sure the concentration of the calibration gas is within the range of each sensor. Do not under any circumstances, use gas that will over-range the sensor.*

The CO span gas can be in the range of 30 - 2000 PPM, 2% accuracy with balance nitrogen, preferably.

The NO span gas can be in the range of 10 - 2000 PPM, 2% accuracy with balance nitrogen, required.

The NO<sub>2</sub> span gas can be in the range of 10 - 500 PPM, 2% accuracy with balance nitrogen, preferably.

The SO<sub>2</sub> span gas can be in the range of 30 - 2000 PPM, 2% accuracy, with balance nitrogen, preferably.

For the NDIR option the following ranges are allowed:

The CO span gas can be in the range of 1.2 – 15.0%.

The CO<sub>2</sub> span gas can be in the range of 9.0 – 20.0%.

The hydrocarbons span gas can be in the range of 1000 - 30,000 PPM, preferably propane.

### **(C) Calibration procedure**

The following page illustrates the sequence of key strokes to carry out a span calibration of the analyzer. It is assumed that the instrument has been autozeroed and there have been no error messages. For the NDIR channels, the span calibration must be carried within 5 minutes of autozeroing the analyzer.

1. Connect the calibration apparatus and cylinder to the instrument.
2. Press the DATA key and observe the appropriate reading as you open the calibration cylinder valve. (If you are using the bypass flow meter, adjust the cylinder valve for a bypass flow rate of approximately 500 cc/min.

**Observe the readings of the other gas parameters for evidence of cross sensitivity and also the oxygen reading for confirmation that there is no instrument leak!**

3. When the display reading for the desired gas has stabilized press the **ZERO/SPAN** key to enter the ZERO - SPAN MENU.

As an example, if you wish to span calibrate the NO sensor using 300 PPM certified gas proceed as follows:

4. Set the time that you must feed the span gas before executing the span adjustment. To do this use the **UP, DOWN & ENTER** keys to change the SPAN TIME parameter.

*NOTE: For NO and CO calibrations a minimum of 4 minutes is adequate. For NO<sub>2</sub> and SO<sub>2</sub> calibrations a minimum of 8 minutes is required.*

5. Enter the NO span value. Use the **UP, DOWN & ENTER** keys to change the NO SPAN value. First set the hundreds digit, then press **ENTER** to advance the cursor to the tens digit, and repeat for the units digit.
6. Pressing **ENTER** again will bring up the DATA screen with the confirmation line: PRESS ENTER TO SPAN. Press the **ENTER** key to begin the calibration. The unit will wait for the amount of time set in step 5. The display will show the time remaining and the span gas value.
7. When the calibration is finished make sure that the display is reading correctly.

#### **(D) Stack Draft Calibration**

To obtain a span calibration of the draft sensor, connect a manometer to the end of the probe through a T fitting. Leave one side of the T open. Restrict the open side of the T with a suitable plug or valve. In the SPAN MENU, use the **UP / DOWN** keys to select a suitable draft calibration span between 5" and 10". Press the **ENTER** key. The pump will be on and the display will read:

PRESS ENTER AT 10" H<sub>2</sub>O.

Very slowly start closing the intake valve of the apparatus and observe the manometer reading climbing. Set the valve opening as soon as the manometer is reading the same pressure as that selected on the display. Press the `ENTER` key again. The draft sensor will be calibrated to the value shown on the display.



## CHAPTER 11

---

### COMMUNICATIONS

The analyzer communicates with a computer through its RS-232 port or its USB port. The analyzer can also communicate wirelessly through its Bluetooth port, if it is equipped. Only one port can be active at a time. The communication protocol is as follows:

BAUD RATE: 9600 baud  
DATA: 8 bits, 1 stop bit, no parity  
HANDSHAKE: None

Communication is by ASCII characters only. Use a USB cable or a 9-pin serial cable to connect the analyzer's serial port to the computer.

The USB drivers must be installed first. They are located on the ENERAC CD, and the ENERAC website: [www.enerac.com](http://www.enerac.com).

The analyzer's RS-232 port is a DTE-type. Only three wires are necessary: pin 2 is TxD, pin 3 is RxD, and pin 5 is ground.

#### A. SERIAL COMMANDS

Start any of the available communications programs, such as PROCOMM™ or TERMINAL on your computer. Make sure the communications program is set to match the ENERAC's protocol listed above.

The ENERAC is capable of responding to commands and requests for data sent from the remote computer. For this purpose, it has a vocabulary of commands that the computer can send and to which the ENERAC will respond. There are two types of commands: those designed for general use, and those reserved for technical purposes in order to determine from remote locations the performance of the instrument.

All commands consist of a four-letter word, which is usually an abbreviation. If the command is followed by a question mark it means that it is a request for information, and the ENERAC will respond with the specific information requested. If a command doesn't contain a question mark it will cause the ENERAC to store the data sent with the command, or take some other action, such as erasing a specific data buffer. This is the way to reprogram the instrument from a remote location. This feature makes remote control possible, as well as the introduction of new fuels or parameters, or even the introduction of additional

features and improvements without requiring the return of the instrument to the factory. A list of the available commands intended for general use follows.

# THE ENERAC 700 COMMAND SET

## DATA COMMANDS

COMMAND	FUNCTION
ATEM?	ENERAC returns present value of ambient temperature.
BATT?	ENERAC returns the battery voltage.
CDOX?	ENERAC returns present value of carbon dioxide.
CMNX?	ENERAC returns present value of carbon monoxide.
COMB?	ENERAC returns present value of combustible gases.
DRAF?	ENERAC returns present value of stack draft.
EFFI?	ENERAC returns present value of combustion efficiency.
EXAR?	ENERAC returns present value of excess air.
NOXY?	ENERAC returns present value of nitric oxide (NO).
NO2Y?	ENERAC returns present value of nitrogen dioxide (NO <sub>2</sub> ).
NOXX?	ENERAC returns present value of oxides of nitrogen (NO <sub>x</sub> ).
OXYG?	ENERAC returns the present value of oxygen.
SO2X?	ENERAC returns present value of sulfur dioxide.
STEM?	ENERAC returns present value of the stack temperature
TEXT?	ENERAC returns a complete record of all current stack parameters.
VELO?	ENERAC returns present value of stack velocity or flow rate.

## SETUP COMMANDS

COMMAND	FUNCTION
ATOF?	ENERAC returns the ambient temperature offset in °C.
ATOF XX	ENERAC sets the ambient temperature offset to XX°C.
COOL?	ENERAC returns the thermoelectric cooler duty cycle.
COOL XX	ENERAC sets the thermoelectric cooler duty cycle: XX=50 50% power XX=100 100% power
CORF?	ENERAC returns the temperature units.
CORF X	ENERAC sets the temperature units: X=F Fahrenheit X=C Celsius
CUST?	ENERAC returns the customer name. This name appears on the display and all printouts.
CUST XXXX	ENERAC sets the customer name, up to 21 characters long.
DATE?	ENERAC returns the present date.
DATE XX/XX/XX	ENERAC sets the present date.
FUEL?	ENERAC returns the current fuel used.
FUEL NN?	ENERAC returns the fuel currently stored in location #NN.
FUEL NN	ENERAC changes its current fuel to fuel #NN (1-15).

MODE?	ENERAC returns the current emissions units.
MODE X	(Emissions option). Causes ENERAC to switch units of emissions gas measurements (CO, NO, NO <sub>2</sub> , NOX, SO <sub>2</sub> ) as follows: X=P PPM (volumetric) X=M MGM (milligrams/cubic meter) X=# #/B (Lbs./million BTU) X=G GBH (grams/brake hp-hour)
OXRFF?	ENERAC returns the oxygen reference.
OXRFF XX	(Emissions option). Causes ENERAC to set the oxygen correction factor to any number as follows: XX=0-20 Percent, in 1% steps XX=21 TRUE (No correction for oxygen)
PUMP?	ENERAC returns pump status: SAMPLE, DILUTE, PURGE, or OFF, and pump duty: 0-100%
PUMP0	Turns the sample pump off & turns the purge pump on.
PUMP1	Turns the sample pump on & turns the dilution/purge pump off.
PUMP2	Turns the sample pump & dilution pump on. (High Range Mode)
PUMP XX	Sets the sample pump duty cycle. (10 < XX < 100)
TIME?	ENERAC returns the current time.
TIME XX:XX:XX	ENERAC sets the current time. (24-hour format)
SIZE?	(Velocity Option) ENERAC returns the stack size. (flow rate only)
SIZE NNN	(Velocity Option) ENERAC sets the stack size, in square inches, used in calculating the flow rate.
VORFF?	(Velocity Option) ENERAC returns the current flow/velocity selection
VORFF X	(Velocity option). Causes ENERAC to switch between stack flow rate and stack velocity as follows: X=V Stack Gas Velocity (feet/second) X=F Stack Gas Flow Rate (cubic feet/minute)

## MEMORY COMMANDS

COMMAND	FUNCTION
BUFF?	ENERAC returns the names of each of the 100 storage buffers.
BUFF NN?	ENERAC returns the name of buffer #NN (0-99).
BUFF NN XX	Sets the name of buffer #NN to XX. Buffer Name can be up to 11 characters.
PRNT XXXX	Sends to the ENERAC printer the message "XXXX" up to 40 characters long. To send more characters, repeat the command.
PRNT TEXT	Commands the ENERAC to print on its printer all the current stack parameters including time, date, fuel and oxygen reference.
DUMP?	ENERAC returns results of all tests stored in its memory.
DUMP NN?	ENERAC returns results of test #NN (0-99).

ERAS NN            ENERAC erases the contents of buffer #NN (0-99).  
 ERAS ALL        ENERAC erases the contents of all 100 buffers.

## **CALIBRATION COMMANDS**

<b>COMMAND</b>	<b>FUNCTION</b>
OFFS?	ENERAC returns a list of voltage offsets for each sensor.
FACT?	ENERAC returns a list of calibration factors for each sensor.
SPAN XX NNN	ENERAC span calibrates sensor XX at a span value of NNN PPM or percent. Be sure to feed the correct span gas and wait for the sensor to stabilize before the analyzer receives this command, as it will execute a span calibration immediately.

		Span Range (NNN)	
XX=CO	Carbon Monoxide	10	2000
XX=NO	Nitric Oxide	10	2000
XX=NO2	Nitrogen Dioxide	10	500
XX=SO2	Sulfur Dioxide	10	1000
XX=CMB	Combustible Gases	0.1	10.0
XX=DFT	Stack Draft (Inches H2O)	-20	+20
XX=COIR	NDIR Carbon Monoxide	1.125	15.0
XX=CO2	NDIR Carbon Dioxide	9.0	20.0
XX=HC	NDIR Hydrocarbons	450	20000

ZERO            ENERAC will perform an autozero of all its sensors.  
 ZERR?        ENERAC returns a list of sensors that failed autozero.

## **MASTER COMMANDS**

<b>COMMAND</b>	<b>FUNCTION</b>
LOGO?	ENERAC returns its current model name (ENERAC M700).
HELP?	ENERAC returns a list of all four-letter commands.
SRAL?	ENERAC returns its serial number.
TURN OFF	ENERAC powers down.
TURN ON	ENERAC powers up. NDIR option will require a ZERO command. This command is not available via a Bluetooth connection.
VERS?	ENERAC returns its current firmware version.
VOLT?	ENERAC returns a list of all system and sensor voltages

## **B. ENERCOM SOFTWARE**

You can enhance the performance and versatility of the ENERAC by using one of the Enercom<sup>™</sup> software programs. Enercom 2000 is available for Windows 95/98/ME/NT/XP. EnercomCE software is available for PocketPCs running WindowsCE. EnerPlam software is available for PalmOS devices. These devices connect to the ENERAC's serial port and offer real-time monitoring of data, additional storage, and remote control.

The Enercom 2000 software is the most robust package, and allows you to:

1. Monitor all emissions parameters simultaneously.
2. Record maximum, minimum, average and standard deviation for all emissions parameters.
3. Set alarms for every emissions parameter including recording the time duration that alarms have been exceeded.
4. Plot bar graphs and time plots of all parameters.
5. Select a variety of saving and printing options.
6. Enter custom fuel information.
7. Retrieve and save stored data.

The Enercom software can be downloaded from the website at [www.enerac.com](http://www.enerac.com). Consult the manual for Enercom for Windows for details on the software.



## CHAPTER 12

---

### MAINTENANCE

The ENERAC micro-emissions analyzers are sophisticated analytical instruments designed to perform accurate emissions measurements. However, because they are hand-held instruments that find uses in many environments, care must be taken to prevent physical and environmental abuse. This will help maintain trouble-free operation.

There are five components that will require periodic inspection or replacement. These are:

1. The non-rechargeable batteries (if you don't use rechargeable batteries).
2. The disposable fiber filter.
3. Removal of condensate from the water trap.
4. Sensor replacement.
5. Printer paper replacement.

#### **A. Battery replacement**

The analyzer requires either 4 or 6 D cells for operation. If you use disposable batteries, select alkaline MnO<sub>2</sub> cells for longer life. You should get at least six hours of operation from a set of batteries, depending on the thermoelectric cooler power requirements, which in turn are a function to a certain extent of ambient temperature.

*The battery charger cannot be used if you are using non-rechargeable batteries! Be sure to toggle the charger switch, located to the left of the paper roll, to the 'Alkaline' position to prevent accidental misuse.*

The instrument is designed to warn you, if the batteries become weak. You can also check the condition of the batteries at any time by pressing the SETUP button. The battery voltage is displayed on the screen. **A minimum of 4 volts is required to operate the analyzer.**

For fresh alkaline batteries the voltage displayed will be approximately 6 Volts.



It will gradually drop with use until at 4.0 volts a “BATTERY LOW” warning will appear. You can estimate the remaining time by observing the battery voltage.

For NiCd or NiMH rechargeable batteries the battery voltage will stay at approximately 4.8 volts for a long time and then drop rapidly.

To replace the batteries, remove all the screws that secure the analyzer’s back plate. The batteries are housed inside a battery holder that is mounted on the back plate. Remove the depleted batteries and replace them with fresh ones observing carefully the polarity indicated. Replace the top section of the back plate.

*NOTE: Remember that the NO sensor needs a tiny amount of electrical power, even when the analyzer is off. Do not allow the batteries to discharge completely. Consequently, you must not leave the analyzer without battery power for any length of time. When replacing the batteries you can use the analyzer within five minutes, if you don’t take longer than two minutes to replace the batteries. If the analyzer has been without power for a long time, you may need to wait for a few hours after installing fresh batteries before the NO sensor is fully conditioned. This warning is for the NO sensor only.*

## **B. Filter replacement**

The disposable 1-micron fiber filter is located in the bottom section of the condensation trap assembly. Its function is to prevent soot particles from reaching the analyzer pump and sensors.

You must replace the filter when it becomes discolored. **Never operate the analyzer without the filter.**

Frequency of filter replacement depends on the type of fuel used. For natural gas fuel you will probably need to replace the filter once a month. For coal fuel you will need to replace the filter every few days.

To replace the filter, disconnect the condensation trap from the probe. Unscrew the bottom section of the condensation trap and replace the filter with a new one. Make sure the O-ring is seated properly when you screw back the bottom section.

## C. Condensation removal

At the end of a measurement, shake the probe vigorously to drain it of any condensation. Remove any condensation that has been trapped in the top section of the condensation trap and allow it to dry thoroughly before storing it.

## D. Sensor replacement

To access the gas sensors you must carefully remove the bottom section of the back plate on which the sensor manifold housing is mounted. This will expose the four gas sensors, the combustibles sensor and the oxygen sensor. (Refer to the figure at the end of the manual) All gas sensors are mounted directly on the printed circuit board.

Make sure the unit is off before attempting to disconnect one of the sensors.

If you receive an error message for one of the sensors during instrument operation, do not attempt to replace the sensor immediately. Instead, wait a few minutes and then autozero the analyzer again. If you get an error message again, investigate and determine if moisture has entered the sensor area. If so, wait a few hours for the moisture to evaporate and autozero the sensor again. If you get a sensor failure then you must replace the sensor.

To replace the sensor, remove the back plate as explained previously. Pull the malfunctioning sensor out of the printed circuit board. Be careful not to bend the mounting pins.

Replace the sensor with a new one. **If the sensor to be replaced is a CO, NO<sub>2</sub> or SO<sub>2</sub> sensor, first remove the shorting spring from the two sensor pins.**

**Each sensor has a different pin arrangement to prevent it from being accidentally inserted in the wrong socket pin configuration!** Be careful not to bend the sensor pins when mounting the new sensor.

Replace the bottom section of the back plate that houses the manifold.

Wait the following time periods before autozeroing the analyzer:

OXYGEN SENSOR	10 MINUTES
CO SENSOR	30 MINUTES
NO SENSOR	24 HOURS
NO <sub>2</sub> SENSOR	30 MINUTES

Span calibrate the sensor as explained in CHAPTER 10: CALIBRATION. If you are installing a pre-calibrated sensor, use the following procedure:

- 1) While holding the **SETUP** key, press the **DISPLAY DATA** key three times. The display will show the sensor factors.
- 2) Press the **DOWN** key until you reach the appropriate sensor, then press **ENTER**.
- 3) Use the **UP / DOWN** keys to enter the correct factor, digit by digit starting with the hundreds digit, press **ENTER** to move through the tens, ones, and tenths digits.

*Sensor replacement should be an infrequent operation (once every two years or more) unless you allow water to enter the sensor housing by not using the condensation trap!*

**NOTE:** SEM four-electrode CO sensor (Hydrogen interference adjustment). There is a hydrogen cross-interference adjustment for the four-electrode carbon monoxide sensor. This calibration, intended to remove the interference of hydrogen from CO measurements, should be rarely done, typically if the sensor is being replaced.

To null the hydrogen interference, feed hydrogen gas, typically 100 - 1000 PPM, following the same procedure as for the other toxic gas calibrations.

## **E. Printer paper replacement**

The printer uses a high quality 2" thermal paper. To prevent damage to the thermal heads, please use only factory recommended paper. Keep any spare paper rolls in a cool dark place to prevent paper discoloration.

To replace the thermal paper, unfasten the two screws that secure the top cover of the printer. Unroll approximately 6" of a new roll of thermal paper. Orient the roll so that the paper unrolls from the bottom of the roll. Be sure that the edge of the paper is cut square. Locate the slot immediately beneath the printer and insert the paper end as far as it will go. Use the feed wheel on the side of the printer mechanism to advance the paper. When the paper end appears exiting printer, feed it through the slot in the top of the unit. Replace the roll on the spindle and replace the cover.

# APPENDIX A

---

## MODEL 700 – SEM SERIES SPECIFICATIONS

### ANALYZER

#### 1. PHYSICAL:

Material: 0.080" thick aluminum case  
Dimensions (analyzer): 9.8" X 5.7" X 3.12"  
Weight: (analyzer) 6 lbs. (4 "D" size batteries included)  
Carrying case (analyzer & all accessories): 17" X 12" x 6.5"

#### 2. POWER:

4 "D" size or 6 "D" size (heavy duty) NiMH rechargeable batteries or alkaline batteries.  
120/240 VAC input, 9 V./2.75 A. fast charger. Charging time: 5 hours.

#### 3. DISPLAY:

2.6" x 1.4" 128 x 64 graphic, chip on glass (white backlit) LCD display.  
Small and large fonts, plus inverted background color for help messages.  
Battery condition & charger operation indicator

#### 1. PRINTER

2" high resolution, high speed, graphic thermal printer, prints:  
A. current set of data  
B. stored data  
C. periodic data printouts  
D. calibration history and external messages.

#### 2. PUMP (SELECT OPTION ACCORDING TO THE MODEL #)

- A. Sample pump: high quality long life motor (5000 hours),
- B. Dilution & Purge pump (option). Pumping system operates in one of the following modes:
  - 1. Continuous sampling, LOW RANGE concentrations
  - 2. Continuous sampling, HIGH RANGE concentrations
  - 3. Periodic sampling (low or high range)
  - 4. Purge mode, also periodic sampling with purge (CTM-22, CTM-30, CTM-34)
  - 5. Pumps OFF mode

#### 3. STORAGE

100 internal memory storage buffers, each buffer stores one complete set of data.

#### 4. COMMUNICATIONS

- A. 9600 baud serial port (RS-232)
- B. USB port (Type B connector)
- C. Bluetooth wireless: Class 1 (100m) (option)

#### 5. SOFTWARE

- A. Enercom™ Windows software
- B. EnercomCE for Windows Mobile PDAs
- C. Enerpalm™ for PALM devices

#### 6. MISCELLANEOUS

- A. Context sensitive HELP key (inverted display background)
- B. 15 fuel internal library
- C. Thermo electrically cooled NO (SEM) sensor for negligible zero drifts.

## SAMPLING & CONDITIONING SYSTEMS (SELECT OPTION ACCORDING TO THE MODEL#)

### 1. CONDENSATION (WATER) TRAP & FILTER SYSTEM

12" or 24" 316 SS Probe, fiber filter, and 34 cc polycarbonate water trap

Sample line: 3/8" OD x 1/4" ID latex braided tubing. Lengths from 10' to 50'.

### 2. THERMOELECTRIC COOLER SYSTEM

**12" – 60" Inconel probe & Peltier cooler with Teflon membrane filter. Manual drain, 34 cc. Water trap. Power required for Peltier: 3 watts supplied by analyzer.**

Sample line: 1/4" OD x 1/8" ID braided Teflon (PTFE) tubing recommended, Viton (optional). Lengths: 10' to 25'

### 3. PERMEATION DRIER SYSTEM. (HEAVY DUTY OPTION REQUIRED)

12" – 100" Inconel probe with sintered Hastelloy filter, fiber filter and Permeation drier system for **CONTINUOUS** water vapor removal. Power required for permeation drier: 12 watts supplied by analyzer.

Sample line: 1/4" OD X 1/8" ID Viton tubing. Lengths: 10' to 100'

### 4. PERMEATION DRIER & VELOCITY PROBE SYSTEM

Permeation drier assembly with integral "S" type pitot tube. Use for mass emission measurements.

## SENSORS

### 1. SEM™ EMISSIONS SENSORS – ELECTROCHEMICAL – MULTI - RANGE SENSORS

SENSOR		RANGE	RESOLUTION	ACCURACY
CARBON MONOXIDE (CO)	LOW RANGE	0-2,000 PPM	1 PPM	2 PPM OR 2% OF READING
	HIGH RANGE	10,000/20,000 PPM	1 PPM	10 PPM OR 5% OF READING
NITRIC OXIDE (NO)	LOW RANGE	0-300 PPM	0.1 PPM	2 PPM OR 2% OF READING
	HIGH RANGE	2,000/4,000 PPM	1 PPM	5 PPM OR 5% OF READING
NITROGEN DIOXIDE (NO2)	LOW RANGE	0-300 PPM	0.1 PPM	2 PPM OR 2% OF READING
	HIGH RANGE	1,000 PPM	1 PPM	5 PPM OR 5% OF READING
SULFUR DIOXIDE (SO2)	LOW RANGE	0-2,000 PPM	0.1 PPM	2 PPM OR 2% OF READING
	HIGH RANGE	6,000 PPM	1 PPM	5 PPM OR 5% OF READING

### 2. INFRARED (NDIR) SENSORS

SENSOR	RANGE	RESOLUTION	ACCURACY
HYDROCARBONS	0-2000 PPM 2001-15000 PPM 15001-30000 PPM	1 PPM	4 PPM OR 3% 5% OF READING 8% OF READING
CARBON MONOXIDE	0%-10.00% 10.01%-15%	0.01%	0.02% OR 3% READ. 5% OF READING
CARBON DIOXIDE	0.00% - 16.00% 16.01% - 20.00%	0.01%	0.3% OR 3% READ. 5% OF READING

### 3. OTHER SENSORS

SENSOR	RANGE	RESOLUTION	ACCURACY
OXYGEN 1- ELECTROCHEMICAL (Concentration)	0 – 25%	0.1%	0.1% ABSOLUTE OR 0.2% OF READING
OXYGEN 2 ELECTROCHEMICAL (High Range – option)	0 – 25%	0.1%	0.1% ABSOLUTE OR 0.2% OF READING
COMBUSTIBLES (Single Range option)	0- 4%	0.01%	10% OF READING OR 0.02%
STACK TEMPERATURE TYPE K T <sup>o</sup> COUPLE	0 – 2000 F. (1100 C)	1 F (1 C.).	5 F. OR 2% OF READING
AMBIENT TEMPERATURE	0 – 150 F. (65 C.)	1 F.	3 F.
STACK DRAFT PIEZORESISTIVE	+10” - -40” WC.	0.1” WC.	0.3” OR 5% OF READING
STACK GAS VELOCITY S TYPE PITOT TUBE	0 – 200 FT./SEC (2” WC.)	1 FT./SEC	MEETS EPA METHOD 2

## COMPUTED PARAMETERS

PARAMETER	RANGE	RESOLUTION	ACCURACY
COMBUSTION EFICIENCY	0 – 100%	0.1%	0.5% OR 2% OF READING
CARBON DIOXIDE (NON – INFRARED)	0 –40%	0.1%	CALCULATED FROM O2
EXCESS AIR	0 – 1000%	1%	CALCULATED FROM O2
OXIDES OF NITROGEN (NOX)	NO + NO2 RANGES	0.1% (SEM SENSORS) 1%	NO + NO2 SPEC'S
EMISSIONS 1 (CO, NO, NO2, NOX, SO2)	0 – 2500 MG/M3	2 MG/M3	CALCULATED BASED ON PPM, O2 AND FUEL
EMISSIONS 2 (CO, NO, NO2, NOX, SO2)	0.00 – 99.99 LBS/MBTU	0.01 LBS/MBTU	CALCULATED BASED ON PPM, O2 AND FUEL
EMISSIONS 3 (CO, NO, NO2, NOX, SO2)	0.00 – 99.99 GMS/BHP- HR	0.01 GMS/BHP-HR	CALCULATED BASED ON PPM, O2 AND FUEL
EMISSIONS 4 (VELOCITY OPTION) (CO, NO, NO2, NOX, SO2 & CO2)	0 .00 – 99.99 LBS/HR 0-99.99 TONS/DAY (CO2)	0.01 LBS/HR 0.1 TONS/DAY (CO2)	CALCULATED BASED ON PPM, O2, STACK VELOCITY AND FUEL
STACK GAS FLOW RATE	0 – 65,000 CFM	1 CFM	CALCULATED BASED ON PPM, O2, STACK VELOCITY AND FUEL



## APPENDIX B

---

### FIRMWARE PROGRAMMING

On occasion it may be necessary to update the internal software of the analyzer, also known as the firmware. The firmware can be updated in the field with the use of a computer connected to the ENERAC through the serial port. Firmware updates can be downloaded from the ENERAC website: [www.enerac.com](http://www.enerac.com), or requested on a disk from the factory. The current firmware version is displayed on the second status screen.

#### **Updating the firmware**

1. Open the paper compartment of the ENERAC and locate the programming switches on the right side. There are 5 miniature slide switches on a red block. Refer to the figure at the end of the manual.
2. Connect the serial port of the computer to the ENERAC. Run the firmware update. The program will backup the ENERAC's settings.
3. When prompted, toggle all the switches on. The firmware will now be reprogrammed. This will take 2-3 minutes.
4. When prompted, toggle all the switches off and replace the batteries and cover. The ENERAC's settings will be restored.
5. Autozero the analyzer. Check the span calibration of all sensors.



