

INTEGRATED
EMISSIONS SYSTEM
MODEL 3000E

INSTRUCTION MANUAL

Enerac, Inc.
1320 Lincoln Ave.
Holbrook, NY 11741

Revision 4
December 2003

TABLE OF CONTENTS

	Page #
LIST OF ABBREVIATIONS	6
LIST OF OPTIONS	8
CHAPTER 1: FUNDAMENTALS	10
A. UNPACKING THE INSTRUMENT	12
B. IMPORTANT ADVICE	13
CHAPTER 2: BASIC INSTRUMENT OPERATION	15
A. STARTING UP THE INSTRUMENT	16
B. ASSEMBLING THE COMBINED STACK-VELOCITY PROBE	18
C. TAKING MEASUREMENTS	19
D. USING THE DUAL RANGE SWITCHES	22
E. SHUTTING OFF THE INSTRUMENT	22
CHAPTER 3: SETTING THE INSTRUMENT RANGE	24
A. BASIC SENSOR SENSITIVITY CONCEPTS	24
B. SETTING THE INSTRUMENT RANGE (SELECTING PCMS)	27
C. INTERFERENCE REJECTION	30
CHAPTER 4: POWER REQUIREMENTS	31
A. BATTERY OPERATION	31
B. AC OPERATION	33
C. DC OPERATION	34
CHAPTER 5: FLOW DESCRIPTION & SENSORS	36
A. THE PROBE ASSEMBLY	36
B. THE SENSOR HOUSING & PUMP ASS'Y	44
CHAPTER 6: CUSTOMIZING YOUR INSTRUMENT	55
A. THE "SET" GROUP OF KEYS	55
B. HOW TO SET YOUR FUELS	58
C. SELECTING THE TEMPERATURE SCALE	59
D. EMISSIONS MEASUREMENTS	61

E. SETTING THE CO ALARM	64
F. SETTING THE COMBUSTIBLES IN ASH	64
G. SELECTING THE INSTRUMENT RANGE	66
H. SETTING THE SPAN CALIBRATION	66
I. TURNING THE PUMP ON / OFF	66
J. SELECTING THE STACK SIZE & FLOW RATE UNITS	66
K. SETTING THE TIME & DATE	68
L. SETTING THE PLOTTER PARAMETERS	68
M. DATA STORAGE	71
CHAPTER 7: USING THE PRINTER	72
A. PRINTOUT OF STACK DATA	72
B. OBTAINING PRINTER PLOTS	74
C. PRINTING STORED DATA	76
D. PRINTING MESSAGES	77
E. CALIBRATION PROTOCOL PRINTOUTS	78
CHAPTER 8: STORING YOUR MEASUREMENTS	79
A. THE STORAGE FUNCTIONS	80
B. HOW TO STORE THE DATA	81
C. RECOVERING STORED DATA	83
D. PERIODIC STORAGE	83
E. ADDITIONAL STORAGE	84
CHAPTER 9: COMMUNICATIONS	86
A. ESTABLISHING COMMUNICATIONS	87
B. THE ENERAC'S LANGUAGE	90
C. ENERAC SOFTWARE	97
D. ANALOG OUTPUTS	97
CHAPTER 10: THE ENERAC'S COMPUTATIONS	100
A. SIMPLIFIED DESCRIPTION	100
B. SENSOR COMPUTATIONS	101
C. HOW EFFICIENCY IS COMPUTED	101
D. EXCESS AIR, CO ₂ & AIR/FUEL RATIO COMPUTATION	103
E. EMISSIONS CALCULATIONS	103
CHAPTER 11: MAINTENANCE	106

A. FILTER MAINTENANCE	107
B. DESICCANT REPLACEMENT	108
C. PAPER REPLACEMENT	109
D. SENSOR AND SENSOR FILTER REPLACEMENT	110
CHAPTER 12: CALIBRATION	116
A. THE ENERAC CALIBRATION PROTOCOL	117
B. AUTO ZEROING THE INSTRUMENT	121
C. INSTRUMENT SPAN CALIBRATION	121
CHAPTER 13: EPA REFERENCE METHOD MEASUREMENTS	134
A. NOX EMISSION MEASUREMENTS	134
SUMMARY OF CTM-022.WPF REQUIREMENTS	139
B. VELOCITY MEASUREMENTS	142
C. HYDROCARBONS MEASUREMENTS	146
APPENDIX A: ERROR MESSAGES & TROUBLESHOOTING	149
A. SENSOR PROBLEM MESSAGES	149
B. POWER PROBLEMS	150
C. FILTER AND PROBE PROBLEMS	151
D. OTHER PROBLEM MESSAGES	154
E. WARNINGS	154
F. MISCELLANEOUS PROBLEMS	156
G. MEMORY PROBLEMS	157
APPENDIX B: MODEL 3000E SPECIFICATIONS	158
APPENDIX C: ENERAC MODEL 3000E OPERATING KEYS	166
APPENDIX D: CORRECTION FOR AMBIENT OXYGEN CONCENTRATION	175
APPENDIX E: DETERMINATION OF THE EXACT NO AND NO ₂ FRACTIONS OF NOX	177
APPENDIX F: INFRARED SENSOR OPTION	178

LIST OF ABBREVIATIONS

ATEMP	Ambient (room) Temperature
CFM	Standard cubic feet per minute (stack gas flow rate)
CO	Carbon Monoxide (A toxic gas)
CO ₂ (CD)	Carbon Dioxide
COMB	(Gaseous) Combustibles
DISPLAY PTR	Display Pointer
EFFI	Combustion Efficiency (for boilers, does not apply to engines).
FPS	Feet per second (stack gas velocity)
GBH	Grams (of pollutant) per (engine) Brake horsepower-hour (dry - basis).
GHR	Grams of pollutant per "input" horsepower-hour
HC	Concentration of hydrocarbons in % measured as propane , NDIR measurement.
IN. W.C.	Inches of Water (Draft measurement).
MGM	Milligrams (of pollutant) per cubic meter (of stack gas)- dry basis.
MODULE xxx	Type of Precision Control Module (determines sensor range)
M.R.G.	Mid range calibration span gas. Must be 40%-60% of the sensor's range.
NO	Nitric oxide (A toxic gas)
NO ₂ (ND)	Nitrogen dioxide (A toxic gas)
NOX	Oxides of Nitrogen (A toxic mixture of NO & NO ₂ gases)
OXY	Oxygen
OXY_REF	Oxygen reference basis for correction of toxic gas concentration.
PCM	Precision Control Module. Sets the range of the carbon monoxide and nitric oxide sensors.
PPM	Parts per million (Volumetric measurement -dry basis)
PRHT	Preheated Air Temperature
SEM TM	New type of compliance level toxic gas sensors
SIZE	Area of stack cross section (square inches)
SNS or SEN	Sensor (type of sensor i.e CO = carbon monoxide)
SO ₂ (SD)	Sulfur Dioxide (A toxic gas)
STEMP	Stack Temperature , degrees F or C.

T/D	Tons (of carbon dioxide) per day- Emission rate -wet basis
U.R.G.	Upper range calibration span gas. Must be 90%-100% of the sensor's range.
X-AIR	Excess Air
#/B	Lbs. (of pollutant) per million BTU(of fuel) - dry basis
#/H	Lbs. (Of pollutant) per hour- Emission rate - wet basis
%	Percent by volume dry basis
^	Indicates on the printer that the dual range switch has been set to the upper, high range position (printer output only!)

ENERAC DISPLAY READOUT, 2 LINES

ENERAC PRINTER OUTPUT

NOTE: FOR ACCURATE NO / NO₂ SPECIATION, REMOVE THE SINTERED FILTER FROM THE TIP OF THE PROBE.

The sintered filter , which is located at the tip of the Enerac's probe is used to prevent heavy soot particles from clogging the front end of the probe. (Coal fuel applications).

This filter, when heated to a temperature in excess of 400 degrees F. will cause reduction of the NO₂ fraction of the stack gases to NO. (This is true of all heated hastelloy, or stainless steel components).

However, the total amount of NOX MEASURED DOES NOT CHANGE!

If you desire to obtain a correct measurement of the exact concentrations of NO and NO₂, remove the sintered filter during measurement, if the stack temperature exceeds 400 degrees F.

LIST OF OPTIONS

The ENERAC model 3000E has been designed as a modular system, permitting the installation in the field of most of the various available options. This manual describes the complete instrument equipped with all the options. The available options on the model 3000E are as follows:

1. 4" SEIKO Printer (Factory installation required).
2. Plotter Printer capability (Requires Printer).
3. Sulfur dioxide (SO₂) measurement capability.
4. Internal 50 test storage option.
5. Internal modem for telephone communication.
6. Emissions option. (Performs calculations in mg/m³, lbs/MMBTU, grams/Brake horsepower-hour or lbs/hour corrected to any oxygen reference)
7. LOW range PCMs for carbon monoxide and sulfur dioxide measurements.
8. Stack velocity and Emission rate (lbs/hour, tons/day) option (Factory installation required).
9. 3.5" diskette with custom program Enercom™ for Windows™ version included with every Enerac model 3000E as a standard option.
10. 36" or 48" inconel probe option. (Longer probes are also available).
11. Heat shield and adaptor to protect probe.
12. Custom fuel option. (Either at the factory, or remotely programmable, if the ENERAC is equipped with a modem or as a menu selection on the ENERCOM program).
13. Measurement of hydrocarbons by state of the art NDIR technology.

Any combination, or all of these options are available to meet the customer's requirements. There is also a variety of cables and attachments available for special connections to the ENERAC (see Appendix C).

Please note that options 2, 3, 4, 5, and 6, if installed in the field, must be activated from the factory via a remote connection to your ENERAC.

The factory telephone number is: (516) 997-2100.

CHAPTER 1

FUNDAMENTALS

The ENERAC Model 3000E Integrated Emissions System is a portable state of the art analyzer designed for the following tasks:

- A. To measure the oxide of nitrogen emissions from stationary combustion sources in accordance with the EPA Provisional Reference Method (EMTIC CTM-022.WPF) for portable NOX analyzers.
- B. To measure the emissions of carbon monoxide, sulfur dioxide and gaseous combustibles and oxygen from stationary and mobile combustion sources.
- C. (OPTIONAL). To compute the emission rates in lbs/MMBTU or lbs/hour (mass emissions) for carbon monoxide, NOX and sulfur dioxide and in tons/day for carbon dioxide according to the EPA's 40CFR75 regulations for continuous emissions monitoring.
- D. (OPTIONAL). To measure the stack gas velocity and volumetric flow rate and emission rates according to the **EPA Method 2 (or Method 2C), Appendix A of 40CFR60.**
- E. (OPTIONAL). To measure gaseous hydrocarbons as propane using the latest state of the art pulsed infrared LED emitter and dual lead selenide detector technology. **Meets EPA's Reference Method 25B Appendix A 40CFR60 "Determination of Total Gaseous Organic Concentration Using a Nondispersive Infrared Analyzer"**.
- F. To assist the operator of a combustion source with the task of optimizing its performance and saving fuel.
- G. To be used as a management tool to assist the plant manager with keeping records and controlling costs.

The ENERAC Model 3000E is the most advanced instrument of its type. It uses the latest proprietary (SEM INSIDE™) electrochemical sensor technology to

measure emissions. To meet the accuracy requirements of the EPA reference methods each SEM sensor is available with two Precision Control Modules (PCM), whose function is to select the measurement range (the ENERAC's analytical range is divided into low, mid and high ranges) that is appropriate for a particular measurement.

The ENERAC also uses the best available conditioning system technology (proprietary battery operated permeation drier configuration) for accurate transport of the sample gas to the instrument. It also uses sophisticated electronics and programming design for increased accuracy and flexibility. It measures 3 temperatures and 6 different stack gases. It computes efficiency of combustion as well as excess air and carbon dioxide. In addition, it computes emissions in five different systems of units (parts/million, milligrams/meter³, pounds/million-BTU, grams/brake horsepower-hour and pounds/hour). It stores, prints and plots data. It communicates with a variety of other computers located near by via its RS-232 port, or remotely by telephone connection. It has eight analog outputs (one for each measurement parameter). It has a library of 15 fuels and over 100 diagnostic and help messages and can operate either on its rechargeable batteries, AC power, or from an external 6 Volt battery, or an 11-36 VDC (external battery system).

Enerac, Inc has years of experience in the manufacture and marketing of combustion and portable emission analyzers. The model 3000E is based on this experience, together with the latest innovations in electronic and sensor technology. It also expresses our basic conviction that communications and artificial intelligence are the basic ingredients of the instrument of the future.

The instrument operates basically as follows:

You select a sensor module (CO, NO) whose range is appropriate to the measurement and set the Enerac (i.e. its range switch and PCM selection) for the chosen modules. You then insert the probe in the stack of an operating combustion source such as a boiler, furnace or combustion engine. A pump located inside the instrument draws a small sample of the stack gas. The sample is conditioned before entering the analyzer. A number of sensors analyze the contents of the stack gas and its temperature and calculate and display the results. In addition, an S type pitot tube measures the velocity of the stack gases. The results can also be printed, stored or sent to another computer either by direct connection or by the telephone lines. The source operator makes the required adjustments based on the analysis of

the stack conditions to optimize performance.

A. UNPACKING THE INSTRUMENT

Every ENERAC model 3000E includes as standard equipment:

1. One Emissions Analyzer model 3000E (includes a roll of printer thermal paper).
2. One stack probe and permeation drier housing.
3. One 14" inconel probe extension and Hastelloy X sintered filter.
4. One set of extra (low range) Precision Control Module for the nitric oxide sensor(standard).
5. One detachable AC power cord.
6. One gas deflector to prolong the life of the filter.(Not available for the velocity probe).
7. One extra Hastelloy X sintered filter and three disposable fiber filters.
8. One instruction manual.
9. One span calibration accessory.
10. One DC power cord with two cable attachment (One for external 11-40 VDC operation the other for external 6 VDC operation).
11. One Enercom TM for Windows TM diskette and instruction manual.

Every ENERAC sold has stored in its memory information regarding manufacturing and sensor dates, as well as product identification, serial number of unit, version and original customer.

B. IMPORTANT ADVICE

Most stack gases are hot, full of moisture, corrosive and laden with particles of soot.

To make sure that your instrument will give you a long time of trouble free performance, please observe the following recommendations.

1. Follow the instructions printed on the stack probe housing.
2. Never use the probe without the primary sintered filter attached to the tip and the secondary fiber filter inserted in the probe housing. Operating the instrument without the filters will damage the permeation drier!
(This is a costly replacement!)
3. To maximize the effectiveness of the drier, you must replace the desiccant (located inside the probe's drier housing) as soon as it turns white!
4. Do not expose the probe tip to open flame.
5. Do not rest the hose of the stack probe on a hot boiler surface.
6. Allow the probe tip to cool off and the instrument aspirate air, before packing the probe.
7. Use the Deflector with any fuel other than natural gas.
8. In dusty environments, cover the printer slot with the Velcro cover and, if possible, cover the face plate of the instrument. **THE PRINTER MAY BE DAMAGED, IF EXPOSED TO DUST!**

9. Avoid exposing the hose to temperatures below 40 deg. F. You might get some condensation.

10. MAKE SURE THAT THE PRECISION CONTROL MODULE MOUNTED ON THE CO AND NO SENSORS CORRESPONDS TO THE PRECISION CONTROL MODULE SELECTED ON THE ENERAC!
USE THE “SET” & “X-AIR” KEYS IN SEQUENCE TO VERIFY PRECISION CONTROL MODULE SELECTION!

CHAPTER 2

BASIC INSTRUMENT OPERATION

It is possible to master the basic operation of the instrument in a few minutes by following the procedure outlined below. Please refer to the other sections of this manual for a description of the more advanced features.

The ENERAC 3000E consists of two major components, the probe whose function is to extract, clean and dry the sample and the main unit, that does the analysis and the computations.

Mounted on the back of the probe, there are five LED indicators. Insert the probe in the stack, only after the instrument has warmed up and the green "PROBE OK" LED has turned on.

If you have the stack velocity probe, make sure the orientation of the S type pitot tube is exactly parallel to the direction of flow in the stack.

The ENERAC is supplied with two Precision Control Modules (PCM) nitric oxide sensor. (One set is already mounted on the sensors!) Selection of the appropriate module and the dual range switch position sets the measurement range of the instrument. See chapter 3 for details.

There are 20 push button switches (keys) on the face plate of the instrument. These buttons are clustered into 4 basic groups. The most important is the group that consists of the eight operating buttons (plus the display pointer) and is located at the center of the face plate. There is a group of three buttons on the left side that, when pressed, will display the three foreground fuels. There are four buttons on the right hand side of the face plate that are used for printing, storing, outputting information and displaying time.

There is also a group of four buttons located directly below the display that are used for setting various parameters and customizing the instrument.

Finally there is a group of momentary toggle switches located on the hinged section of the face plate whose function is to change the upper range of the

analyzer.

For simple measurements you only need to use the basic 8 buttons.

Before starting your measurements you should decide on the instrument range for CO and NO and select and install the appropriate Precision Control Modules (PCM) on your Enerac. The standard factory equipped ENERAC arrives with the MID PCMs mounted on the sensors giving a default dual range of the analyzer as follows:

Carbon monoxide: 2000/20000 PPM.

Nitric oxide: 1000/4000 PPM. (Also supplied separately: 300/1000 PPM).

Nitrogen dioxide: 500 PPM.

Sulfur dioxide: 2000/6000 PPM.

The analyzer is designed to read 20% above the indicated ranges.

A. STARTING UP THE INSTRUMENT

If your ENERAC is equipped with the velocity option, you should have the combined STACK-VELOCITY probe. Assemble the combined probe following the instructions listed at the end of this section.

For units equipped with the standard probe proceed as follows:

1. Remove the probe and hoses from their compartments inside the analyzer case. If the temperature is less than 40 degrees Fahrenheit, wait a few minutes for it to warm up.
2. If the stack diameter exceeds 24", connect the extension tube to the probe tip. Make sure the sintered filter and deflector are attached to the tip of the probe.
3. Make sure that the range of CO and NOX emissions you intend to measure do not exceed the ranges of the Precision Control Modules (PCM) currently installed in your analyzer (i.e. make sure the desired PCMs are installed).

4. Connect the hose end of the probe to the gas fitting on the face plate of the ENERAC marked "GAS IN".
5. Connect the cable end of the probe to the ENERAC connector marked "ELECTRICAL".
6. Turn the instrument on. The " BATTERY OK" light should turn on steady. The display should read:

**CHECK PCM RANGE SETTINGS
Press Enter to Continue**

The display is reminding you to make sure the correct PCMs are mounted on the sensors.

Assuming that the correct PCMs have been installed as outlined above, press the "ENTER" key. The following message will appear on the display:

**SNS:CO PCM:2K PPM(M)
Up/Down-Change; Enter-OK**

This is a reminder that the ENERAC assumes that the mid range PCM (factory default) is mounted on the CO sensor and the dual range switch is set for the 2000 PPM range. (If the dual range switch was toggled to the upper range, the display would read 20000 PPM, instead).

Proceed to press the "ENTER" key repeatedly until the following message appears on the display:

**Press ENTER to AUTOZERO
Any Other Key Bypass**

If you have AUTOZEROED the unit during the past 24 hours, you

probably don't have to AUTOZERO it again. You can by pass the AUTOZERO procedure by pressing any key other than the "ENTER" key. If you wish to perform an AUTOZERO, press the ENTER key. The following message will appear on the display:

**AUTOZEROING
WARMING UP: XXX SEC**

7. At the end of the warm up period a number of messages may appear. If everything is OK with the unit, only the following message will appear:

**INSERT PROBE IN STACK
ATEMP: XXF OXY: XX.X%**

(If a "...AUTOZERO ERROR" message appears, see Appendix A for help).

At the end of the AUTOZERO period, the printer will operate automatically providing a record of performance of the autozero.

8. You are now ready to begin your measurements!

While the instrument is warming up, the probe is also being heated, simultaneously.

**WAIT UNTIL THE GREEN "PROBE READY" LIGHT TURNS
ON BEFORE YOU INSERT THE PROBE IN THE STACK!**

As soon as the "PROBE OK" LED turns on, you are now ready to get started with your measurements.

B. ASSEMBLING THE COMBINED STACK-VELOCITY PROBE

(Ignore this section, if you don't have the velocity option).

The COMBINED STACK-VELOCITY PROBE (S-V) unlike the standard probe, detaches completely from the probe case and is supplied in different lengths. See Chapter 5, figure 8 for a complete description of the S-V probe.

Read chapter 13 on EPA reference method measurement requirements, before using the S-V probe.

To use this probe properly you must orient the Pitot tube section of the probe so that the Pitot tube openings point exactly in line with the direction of the stack gas flow.

- a. Rotate the combined S-V assembly so that the notch of the locating washer fits into the appropriate groove of the probe support manifold and thus orients the S type Pitot tube in the desired direction.
- b. Push firmly the stack probe into the manifold and secure it in place by screwing the stainless steel cap to the probe manifold.
- c. Connect the two hoses that are mounted on the ends of the Pitot tube to their respective fittings located on top of the probe case.
- d. Insert the thermocouple connector to its mating jack located in the front of the probe case. This completes the S-V probe assembly.

Remember to hold the probe so that the open ends of the Pitot tube are exactly in line with the stack flow direction. Because of turbulence the best way to determine gas flow direction is to locate the orientation of minimum flow and then orient the probe perpendicular to it! It also preferable to insert the probe as near the middle of the stack cross section as possible, unless you are taking traverses!

C. TAKING MEASUREMENTS (SEE ALSO APPENDIX E)

You should have a ½" diameter hole drilled to your stack wall.

Insert the probe in the stack. Anchor the **standard** probe to the stack wall by inserting the top end of the sliding probe support into the hole in the stack wall.

Push the Fuel button that corresponds to the fuel of your choice.

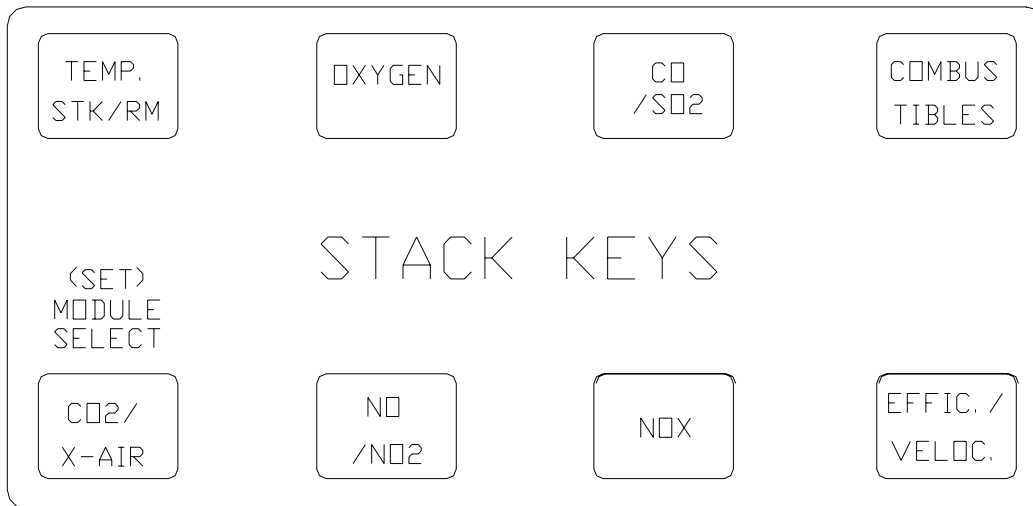

FIGURE 1

If your fuel is not one of the three fuels that are displayed when pressing one of the fuel buttons, see Chapter 6 for instructions on setting fuels.

1. You can now read on the display any four stack parameters that you wish simply by operating any of the eight basic buttons shown in Fig.1.

If you have installed the hydrocarbons option, the “combustibles” key will display “hydrocarbons”.

Use the “DISPLAY PTR.” button to display any combination of the stack parameters that you wish to view simultaneously. See fig.2.

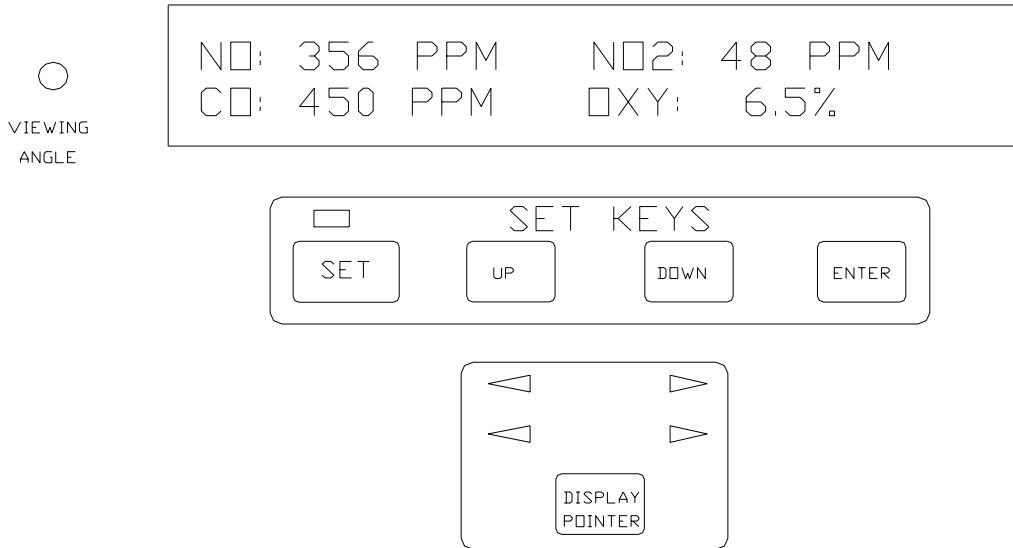

FIGURE 2

2. During your measurements you should observe the status lights that are located on the probe housing mounted on the stack wall. These lights are important monitors of the condition of the filter and the probe temperature.

NOTES:

- a. *The display is divided into four quarters. You can display any stack parameter on either side by using the "DISPLAY POINTER" key and observing the section of the display to which one of the four display pointer LEDS is pointing.*
- b. *The buttons "TEMP/ST-RM", "CO₂/X-AIR", "NO/NO₂", "CO/SO₂" and "EFFIC./VELO" are toggles. You display the alternate Parameter by pressing the same button again.*
- c. *If the stack draft exceeds +3" W.C. the red "NO FILTER FLOW" LED may turn on. Ignore it and proceed with your measurements!*
- d. *If the "OVERHEATING" light turns on, you must remove the probe from the stack immediately, to avoid permanent damage to the probe.*
- e. *You should also observe periodically the moisture condition of the small*

piece of clear tubing located near the probe housing. The interior of the tubing should be clear with no evidence of condensation.

CAUTION:

If during your measurements, you suddenly see all display pointer LEDs flashing and you hear the beeper beeping periodically REMOVE IMMEDIATELY THE PROBE FROM THE STACK. This is an indication that one or more of the ENERAC sensors has over ranged and there is a danger of saturating the sensor.

D. USING THE DUAL RANGE SWITCHES

It is good practice to carry out the AUTO ZERO procedure with the dual range switches set in the LOW range position.

It is also a good practice, before inserting the probe into the stack, to toggle the dual range switches to their upper position to reduce the possibility of over ranging and saturating the sensors.

The ENERAC is designed to give warning, if the concentration of the gas is close to exceeding, or exceeds the sensor's (PCMs) designed upper range. The warning is both visual (all the face plate LEDs will begin to flash) and audio (the analyzer's buzzer will turn on). If this happens, toggle immediately the affected sensor's dual range switch to its upper position. In the unlikely case that this warning is given with the toggle switch already in the upper position, withdraw immediately the probe from the stack and allow it to aspirate ambient air.

E. SHUTTING OFF THE INSTRUMENT

1. Remove the probe from the stack. Do not touch the hot metal probe.
2. Allow the instrument to run for one minute aspirating ambient air to purge any remaining gases.
3. Turn the unit off. Allow a few minutes for the probe to cool down. Check the condition of the desiccant. If its color has changed to white, replace it with fresh desiccant. Store the probe in its compartment.

Do not forget to give the batteries a fresh charge before using the ENERAC again.

If you accidentally turn the instrument off while the probe is in the stack (or, if for any reason the instrument locks up and the buttons become inoperative), turn the ENERAC off and then turn it on again. Press the "ENTER" key repeatedly. When the message

**Press ENTER to AUTOZERO
Any Other Key Bypass**

appears on the display, press any key other than the "ENTER" key. The ENERAC will bypass the autozeroing procedure and you can continue with your measurements.

CHAPTER 3

SETTING THE INSTRUMENT RANGE

(You may by pass this chapter, if you do not plan to change the precision control modules that are mounted on the CO, NO and SO₂ sensors).

The ENERAC model 3000E is designed for the measurement of emissions from stationary combustion sources. It is not intended to be used for ambient emission measurements, where concentrations of less than 5 PPM are expected.

The analytical range of emissions by stationary combustion sources can be estimated as follows:

Carbon monoxide(CO): 10 PPM to 20,000/40,000 PPM

Nitric oxide (NO): 10 PPM to 5000 PPM

Nitrogen dioxide (NO₂): 5 PPM to 500 PPM

Sulfur dioxide (SO₂): 10 PPM to 5000 PPM

A. BASIC SENSOR SENSITIVITY CONCEPTS

Portable emission analyzers use electrochemical diffusion sensors for the measurement of emissions. Gas is introduced through a diffusion capillary into the sensor and the electrochemical reaction gives a signal proportional to the concentration. The sensitivity of the sensor is proportional to the size of the capillary.

If the gas concentration is too low for a given capillary size, the sensor will exhibit large zero drifts with temperature. If the gas concentration is too high for a given capillary size the sensor's sensitivity will deteriorate during a measurement. **For standard electrochemical sensors the accuracy(i.e. small zero drift and insignificant sensitivity deterioration) for a given capillary size can be maintained over a range of approximately one order of magnitude (i.e. a factor of 10).**

The SEMTM sensors are specifically designed for emission measurements and

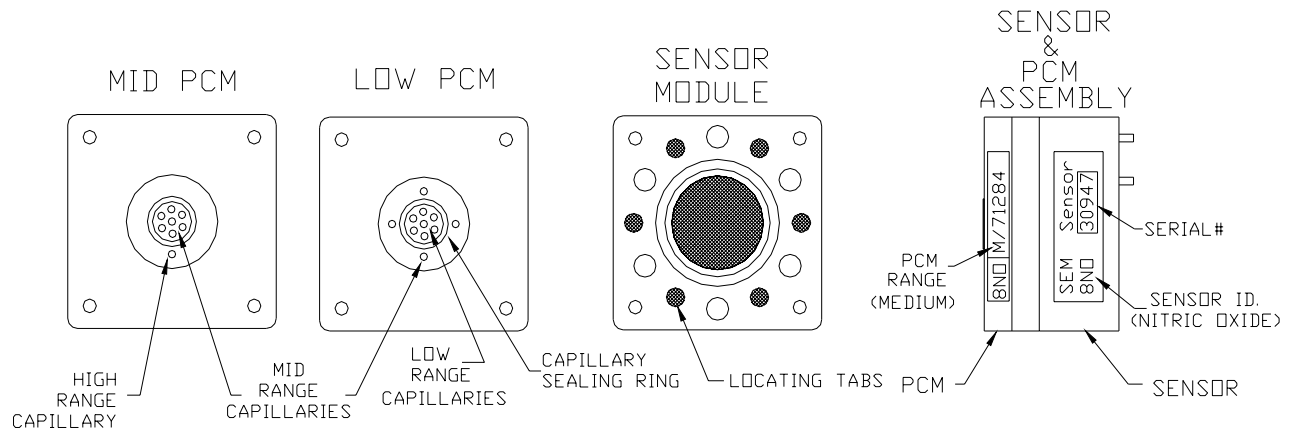

SEM SENSOR

FIGURE 3

can maintain accuracy over a wider range than one order of magnitude. In addition, by separating the sensor assembly (known as the sensor module) from the capillary assembly (known as the precision control module or PCM) it is possible for the analyzer to cover the entire analytical range listed above with great accuracy.

This is accomplished by designing two precision control modules for each sensor, each module in turn is designed with two sets of capillary openings. The two sets of capillary openings are separated by a sealing ring. See figure 3. Please notice that the capillary area (i.e. sensor sensitivity) for the upper range of the LOW PCM is approximately equal to the capillary area of the lower range of the MID PCM, resulting in three different ranges for the two PCMs.

The ENERAC model 3000E is set at the factory with the MID range PCMs mounted on the sensors. In addition, the LOW range nitric oxide (NO) PCM is supplied standard with every analyzer to conform with the EPA's CTM-022 reference Method. The LOW range PCM for carbon monoxide are optional and should be ordered only if it is desired to measure very low concentrations, typically less than 60 PPM.

To reduce the need for changing frequently the two PCMs, a solenoid piston located directly above each PCM can be activated by toggling one of the dual range switches located on the left side of the face plate.

The solenoid piston descends on top of the sealing ring thus shutting off the inner set of capillaries from the gas and **reducing the intrinsic sensitivity of the sensor.** See figure 4.

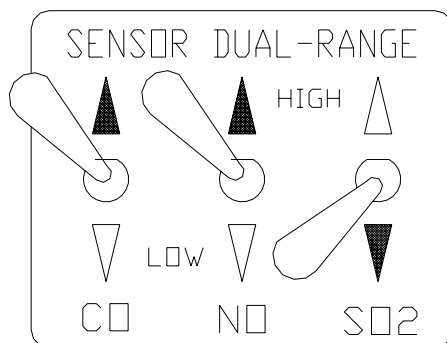

FIGURE 4

Dual range switches for carbon monoxide, nitric oxide and sulfur dioxide are standard for the Enerac model 3000E . *The dual ranges of the sensors are listed in Table 1.* Figure 4 shows the location of the dual range switches on the Enerac’s face plate.

You operate the dual range switch by pushing the lever in the desired direction to select the appropriate range and then releasing the lever to allow it to return to its center position (these are momentary switches). The triangular LEDs above and below the switches turn on alternatively, as the corresponding switch is toggled. The “ON” LED indicates the selected range (low or high) for the PCM used.

NOTE: If you don’t remember the upper limit of the range, use the “SET” and “X-AIR” keys in sequence. The upper limit will be displayed for each sensor.

When switching ranges, allow a few seconds for the sensor to reach equilibrium conditions. It takes approximately 20 seconds for the sensor to reach steady state following a change in its range. *Do not allow a sensor to over range!*

The module (PCM) selected for the particular sensor determines the values of the upper and lower ranges for that PCM, as shown on Table 1.

Each sensor range can be selected independently by activating the appropriate dual range toggle switch.

B. SETTING THE INSTRUMENT RANGE (SELECTING PCMS).

1. As described above, two PCMs are available, with each carbon monoxide and nitric oxide (normally the MID range PCM is already mounted on the sensor

from the factory). **Each PCM has two ranges! (The high range of the LOW PCM is the same as the low range of the MID PCM giving thus a total of three ranges for each sensor.** Selection of the appropriate PCM (LOW or MID) for each sensor sets that sensor's maximum range. The table below lists the maximum ranges for each PCM marked "L" (low range) and "H" (high range).

SENSOR	PCM TYPE	LOW RANGE	HIGH RANGE
CO	LOW	500 PPM	2000 PPM
CO	MID	2000 PPM	20,000 PPM
NO	LOW	300 PPM	1000 PPM
NO	MID	1000 PPM	4000 PPM
SO ₂	MID	2000 PPM	6000 PPM

TABLE 1

PRECISION CONTROL MODULES-MAXIMUM MEASUREMENT RANGE

The NO₂ sensor has a single maximum range of 500 PPM and is not supplied with any PCMs.

For each sensor select the PCM with the lowest range that will not be exceeded during your stack measurements. If you are not sure of the stack concentrations use a higher range module (less sensitive).

2. To install the appropriate PCM, lift the hinged section of the face plate and locate the appropriate sensor.

PCMs are designed to fit only on top of their respective sensors, only! (i.e. a CO PCM will not fit on an NO or SO₂ sensor!

3. Remove the four thumbnuts that secure the sensor and PCM assembly to the unit's aluminum sensor housing. Gently remove the sensor assembly from the supporting threaded rods.

Do not disconnect the small PC board that is located on the back of the sensor.

4. Remove the existing PCM from the front of the sensor and replace with the new PCM, orienting the PCM so that its guides line up with the sensor holes.
5. Repeat the procedure for the remaining sensors as needed.
6. Turn the instrument on. Bypass the AUTOZERO procedure and any other messages by pressing the “ENTER” key repeatedly, until the following message appears on the display:

**INSERT PROBE IN STACK
ATEMP: XXF OXY: XX.X%**

7. Press the “SET” and “X-AIR/CO2” keys in sequence. One of the following messages will appear on the display:

**SNS:XX PCM:ZZZ PPM(Y)
Up/Down-Change; Enter-OK**

where, SNS stands for sensor type,

XX = CO or NO - (selects the appropriate sensor)

Y = (L) or (M) - (selects the appropriate PCM that you have just installed (LOW or MID).

ZZZ = 300, 1K, 2K, 7K or 20K - (displays the upper range of the selected module (Depends also on the setting of the dual range toggle switch).

You must enter the correct type of PCM! If you don't, you will have caused the following errors:

a. If you proceed to carry out a span calibration of the instrument you will receive a “CALIBRATION FAILED” message.

b. If you proceed to take measurements, you will get errors by a factor of three or more!!!! YOU MUST ENTER THE CORRECT PCM RANGE!!!

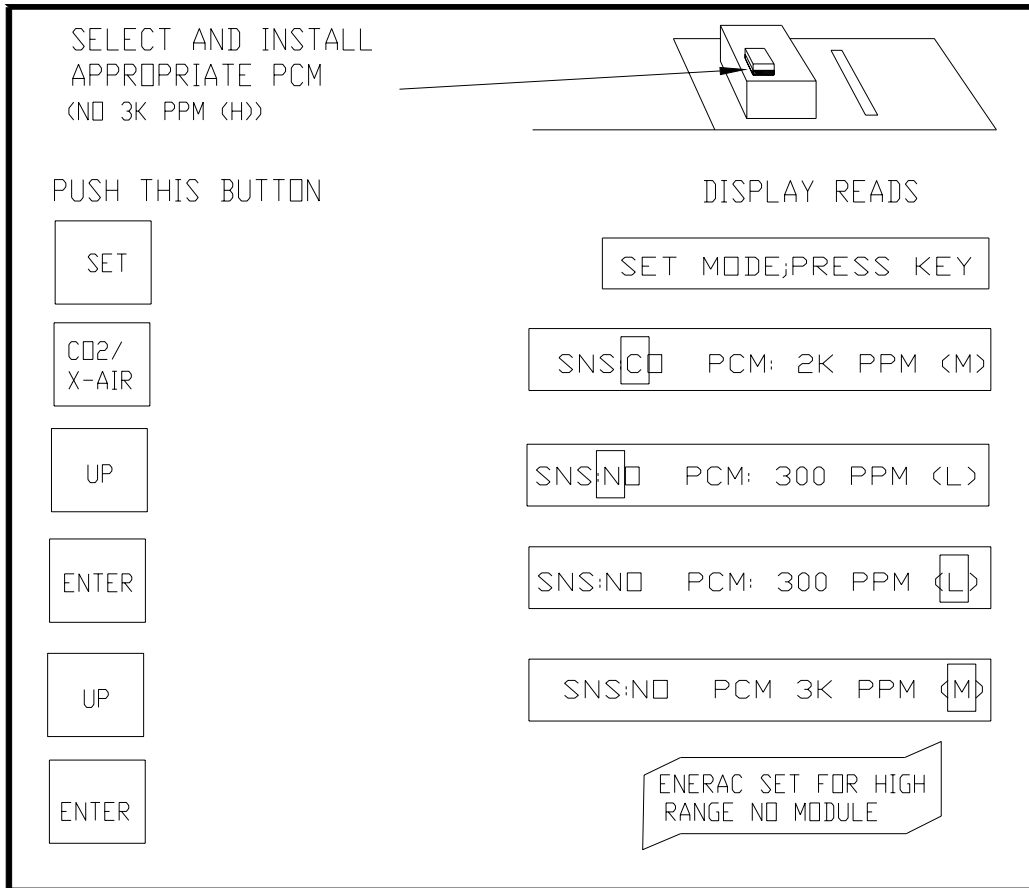

FIGURE 5

8. Use the “UP” and “DOWN” keys to select the appropriate sensor first. Then press the “ENTER” key to shift the display cursor to the “PCM” position. Use the “UP” or “DOWN” keys to select the appropriate PCM (i.e. L-low Range, or M-high).
9. You may experiment by toggling the respective dual range switch up and down. Observe the corresponding triangular LEDs turning on and off. Also observe the display. The letters “L” and “M” will alternate indicating that the analyzer understands you are changing the instrument’s range and making the necessary adjustments.
10. Repeat the procedure for the remaining sensors whose PCM has been changed.

Figure 5 shows the steps to follow in replacing an already installed low range NO module with a mid range module.

C. INTERFERENCE REJECTION.

The carbon monoxide and nitric oxide precision control modules have an additional function besides setting the sensor's intrinsic sensitivity.

These two PCMs incorporate special proprietary inboard chemical filters, whose function is to remove interfering gases from reaching the sensors.

These filters have a long but limited life. When their capacity is exhausted the appropriate PCM must be replaced with a fresh one. These are available from the factory. The ENERAC will give warning of impending filter exhaustion. See the chapters on maintenance and calibration for details.

CHAPTER 4

POWER REQUIREMENTS

The ENERAC model 3000E can be operated from a variety of power sources. These are: (1) its own rechargeable battery, (2) by plugging it to a suitable 120 VAC or 230 VAC outlet, (3) by plugging it to any 11-40 VDC power source, such as an external battery and (4) by plugging it to a 6 VDC battery similar to the one located inside the instrument.

A. BATTERY OPERATION

The instrument's battery pack consists of a single 6 Volt rechargeable sealed lead acid cell. The cell is housed inside the power supply section of the unit and is rated at 10 AH. This means that it will operate the instrument for approximately 2-4 hours on a single charge (depending on environmental conditions).

The "BATTERY OK" light, located just above the ON-OFF switch, shows the condition of the battery.

1. As long as the battery is in GOOD CONDITION, the "BATTERY OK" LED will stay ON.
2. When the battery BEGINS TO WEAKEN the light will begin to FLASH. It will keep flashing for approximately 5-10 minutes, unless the unit is plugged to an external power source.
3. When the battery BECOMES VERY WEAK, the instrument will be AUTOMATICALLY shut off by a battery monitoring circuit to prevent the battery from becoming totally depleted.
4. There is a very small drain on the battery, even when the instrument is turned off. Sensor bias and the internal clock circuits stay on and will eventually drain the battery completely after 8-10 months.

If the instrument turns off because of a depleted battery, plug the AC or DC power cord to a suitable outlet and continue your measurements ,or turn the instrument

off and charge the battery. It requires approximately 4 hours for a complete charge.

5. To recharge the batteries plug the instrument to any convenient POWER SOURCE. This can be either an AC outlet or a DC power source(11-40 VDC) such as a automobile battery.
6. The ON/OFF switch module can be set for either 120 VAC or 230 VAC. The current setting is shown on the face of the module. If you wish to change the setting, lift the tab that covers the module, pull out the plastic insert that indicates the voltage setting and insert it so that the correct voltage setting is shown on top. See figure 6.

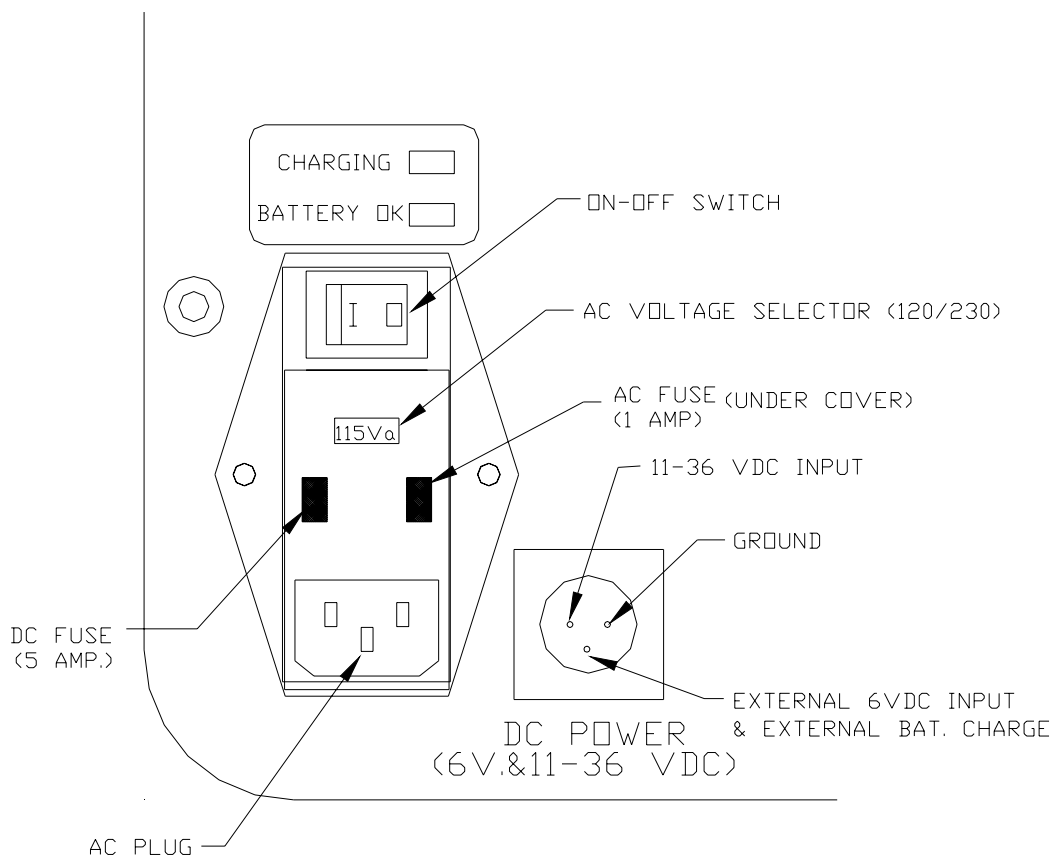

FIGURE 6

As soon as the instrument is plugged to a functioning power source, the "CHARGE" LED will turn on indicating that the batteries are being charged. (If

you connect the instrument to a DC power source and the "CHARGE" LED does not turn on, check to see if you are properly connected to a suitable DC source!).

B. AC OPERATION

Before plugging the instrument to an AC outlet, make sure the outlet voltage is the right one for the instrument. Domestic units operate on 110-125 V. 60 Hz. Export units are usually operated on 220-240 V. (You may need a suitable adaptor to plug the AC cord to a non U.S. socket).

The ON/OFF switch module includes the AC socket, the ON-OFF switch, a 1.0 Amp. fuse (for AC voltages) , a 5.0 Amp. fuse (for DC power), an AC voltage changing adaptor (insert) and an EMI/RFI filter for compliance with the FCC regulations.

The fuses can be reached by simply lifting the AC module's plastic cover using a small screwdriver.

The 1.0 amp fuse located on the left side of the Switch Assembly is the ac power fuse and the 5.0 Amp fuse located on the right side of the Switch Assembly is the dc power fuse!

When the unit is operating on AC, the battery receives a small charge.

CAUTION:

If your AC power is subjected to frequent "brownouts", or, if you are operating large motors in the vicinity, you should avoid using the ENERAC on AC power. Even though the unit has built in protection, AC lines with frequent problems may eventually cause corruption of data stored in its temporary memory. (It will not affect data stored in its permanent memory). If you notice corruption of data on the display or on the ENERAC printout, turn the unit OFF and then turn it again back ON. This should correct the problem.

C. DC OPERATION

Many applications, such as stationary combustion engines, require numerous measurements in remote locations, where there is no AC power.

The DC power option is a convenient way to operate, or charge the instrument from an external DC power source that can be either:

1. An external 6 Volt battery with a capability of 5 AH or better .

If you are going to use an external 6 Volt battery, it is recommended that you use an external 6 Volt battery similar to that used by the ENERAC (i.e. a 10 AH sealed lead acid battery). Use the 10 ft. DC cable supplied with the ENERAC. Connect the “6 Volt extension” cable (i.e. the extension cable terminating in spade lugs!) to the end of the 10 ft. Cable.

NOTE: You can recharge the external 6 Volt Lead acid battery, by connecting it to the ENERAC using the “6 Volt extension” cable and 10 ft. DC cable and plugging the instrument to a convenient AC source. The ON/OFF switch should be in the “OFF” position. It will take several hours for a complete charge since the instrument will be charging two batteries in parallel (its own plus the external battery, simultaneously).

2. Any "reasonably clean" source of DC voltage from 11 to 40 VDC capable of delivering more than 5 Amps.

Use the 10 ft. DC cable supplied with the ENERAC. Connect the “ 11-40 Volt extension” (i.e. the extension cable terminating in alligator clips!) To the end of the 10 ft. Cable. Te alligator clips must be connected with the correct polarity.

However, there will be no damage to the instrument, if you connect them with the wrong polarity.

Use only the cable supplied with the ENERAC to connect the instrument to the DC source. The ENERAC requires less than 17 watts for operation. For a 6 Volt battery assume operation of 80% of its AH rating. For a 11-40 V DC source assume a conversion efficiency of 70%. Consequently, you can estimate the amount of time that it will run on an external battery source.

Turn the instrument off, if you wish to charge the unit's battery quickly (i.e. in 4 hours). Make sure the "CHARGE" LED is on.

COLD WEATHER NOTICE:

If you are taking measurements outdoors and if the outdoor temperature drops below 32 degrees F (0 C.), it is recommended that you use the instrument on AC, or on an external DC source. The power supplied by the unit's battery to the probe may be insufficient to heat it to the required temperature for proper operation. If you must use the unit on batteries in cold weather, take the necessary precautions to insulate the probe and warm it up by taking advantage of the heat from the stack!

Make sure the green "OK" LED turns on.

CHAPTER 5

FLOW DESCRIPTION & SENSORS

During operation, the metal tube of the probe (see fig.5) is inserted into the stack. A small pump located inside the unit draws a sample of the stack gases into the instrument for analysis. The probe assembly and the sensor housing are described below.

A. THE PROBE ASSEMBLY (SEE ALSO APPENDIX E)

The probe assembly of the ENERAC 3000E is unique, for a battery operated instrument, in its capability to filter, dry and condition the stack gas sample.

Gases such as nitrogen dioxide (NO_2) and to a lesser extent sulfur dioxide (SO_2) react to a certain extent with the water condensate. They are also easily adsorbed to the surface of most types of materials. The probe must, therefore, remove the water without condensation, remove the particulates from the sample stream and be constructed of materials that will not adsorb these gases.

The probe assembly consists of an inconel probe, the main probe housing and a standard 10' length of hose and electrical cable.

1. The inconel probe

The inconel probe is a five piece assembly of metal tubing. It consists of the following parts.

- a. A 10" section of 3/8" diameter inconel tube that is threaded to the probe housing. The instrument thermocouple is located inside this tube.
- b. A 13" piece of extension inconel tubing to be used with stacks having a diameter larger than 24". The extension tubing screws on the above piece to increase the effective probe length to 24". Figure 7 below shows the various components of the probe.

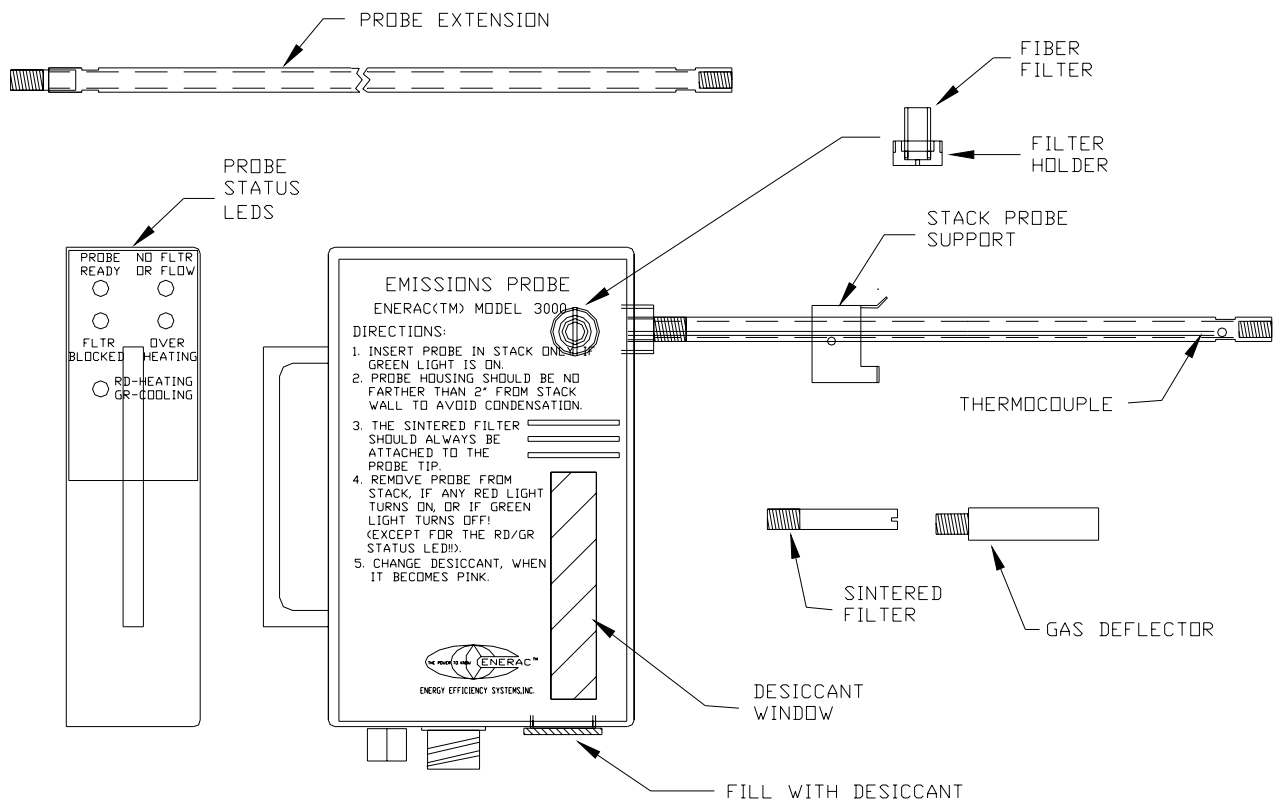

FIGURE 7

- c. A 1" long sintered Hastelloy X filter. The purpose of the filter is to block soot particles from entering the probe housing. The filter is reusable to a certain extent and can be cleaned a few times in an detergent and by blowing air from inside out. A light located on the probe housing monitors the condition of the filter. Maximum filter temperature is 1900 degrees F.

You must never operate the instrument without the sintered filter. Such operation will damage the probe.

- d. A ½" diameter soot particle deflector. The purpose of the deflector is to create a flow stream for the soot particles around the filter and thus prolong its life. (Probes equipped with the S-V pitot tube for velocity measurements do not use the deflector!)

- e. A support bracket. The purpose of the bracket is to support the probe assembly so that it can be mounted on the stack wall.
Mount the probe at a distance from the stack wall that will not exceed the housing's maximum temperature of 160 degrees F. but not so far as to cause condensation inside the inconel tubing. The exposed part of the inconel tube should remain at a temperature that appears too hot to the touch in order to prevent condensation.
- f. Heat shield and adaptor (optional). This aluminum shield is intended to protect the probe housing from any very hot stack gases escaping from the opening in the stack wall (typical in engine applications).

To use the shield slide it over the probe placing it as close to the probe housing as possible. Secure it by tightening the set screw. To use the adaptor that comes with the shield you should have a female 3/4 PT fitting mounted on the stack wall. The purpose of the adaptor is to seal the opening and support the probe assembly.

1a. The stack-velocity (S-V) probe. (OPTIONAL)

If the ENERAC is equipped with (S-V) type of probe option, the section of the ENERAC's probe that is inserted in the stack consists of three sections. These are shown in fig 8.

NOTE: For EPA reference method measurements on small stacks having diameter smaller than 12", please read chapter 13 for the recommended measurement method using a standard pitot tube.

The gas extraction probe. This is a 3/8" diameter piece of inconel tubing fitted with a 10 micron sintered Hastelloy filter at the tip. The purpose of the filter is to block soot particles from entering the probe housing. The filter is reusable to a certain extent and can be cleaned a few times in an detergent and by blowing air from inside out. A light located on the probe housing monitors the condition of the filter. Maximum filter temperature is 1900 degrees F.

You must never operate the instrument without the sintered filter. Such

operation will damage the probe.

The S type Pitot tube. It consists of two pieces of 3/16" diameter stainless steel tubing with the tips open and bent at a certain angle according to the EPA specifications of 40CFR60 App.A method 2 for measuring stack gas velocities. The Pitot tube must always be oriented with the open tips parallel to the direction of the stack gas flow. Care must be taken to keep the tubes from getting clogged by soot particles. The end of the Pitot tube assembly is connected by means of two flexible hoses to a very accurate low pressure transducer located inside the probe case.

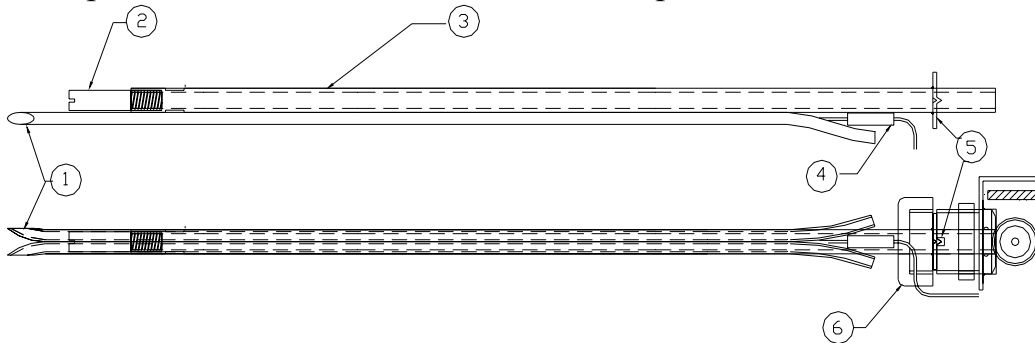

1. S TYPE PITOT TUBE
2. HASTELLOY SINTERED FILTER
3. GAS EXTRACTION TUBE
4. INCONEL SHEATHED THERMOCOUPLE END
5. PITOT TUBE ORIENTING NOTCH AND GROOVE
6. PROBE RETAINING CAP

FIGURE 8

The Pitot tube is welded to the gas extraction tube. Two pieces of flexible high temperature Viton hose connect the Pitot tube to the low pressure sensor located inside the probe case.

The thermocouple. A type K inconel sheathed thermocouple having a length approximately equal to the length of the gas extraction tube fits snugly in the space between the Pitot tube and the gas extraction tube. The thermocouple is connected to a flexible thermocouple wire that terminates to a quick disconnect. During measurement move the thermocouple tip slightly, so that it is not in contact with the pitot tube.

The hole probe assembly can be detached from the probe case and stored

elsewhere. This makes it possible to use interchangeable probes of different lengths using the same instrument and probe case.

2. The probe housing

The probe housing consists of a rectangular aluminum box whose external dimensions are the same for both the standard probe and the S-V velocity probe assembly. The similarity, however, ends there. The S-V velocity probe utilizes an embedded micro controller that checks the operation of the probe analyzes temperature and velocity information and communicates with the main section of the analyzer through its serial port.

The probe housing contains a permeation type drier, whose function is to remove the excess water vapor that is present in the sample and thus, prevent condensation of moisture in the hose assembly. It also houses a secondary fiber filter for added protection.

Nitrogen dioxide and to a lesser extent sulfur dioxide react readily in water and any condensation present in the hose assembly would result in erroneous readings.

The probe housing consists of the following components.

- a. **The secondary fiber filter.** This is a small cylindrical 0.5 micron glass fiber filter for the removal of the finer particles from the gas stream. It is accessed from the side of the probe (see Figure 7). This filter should be replaced periodically.
- b. **The permeation drier assembly.** This assembly consists of the permeation drier, a support manifold for the heated probe and a pump that supplies the counterflow air to the drier. The drier is designed to reduce samples containing as much as 20% water vapor to a dew point of 50 degrees F., or lower. The drier assembly is located inside the probe housing, with the exception of a small piece of clear tubing that is located just outside the probe.
- c. **The clear tubing.** The piece of clear tubing located at the end of the probe functions as a monitor to check for moisture condensing on the

walls of the hose. If you observe condensation, you must reduce the sample pump flow rate.

Before attempting to reduce the flow rate make sure that the exposed section of the inconel tube is hot, as explained above!

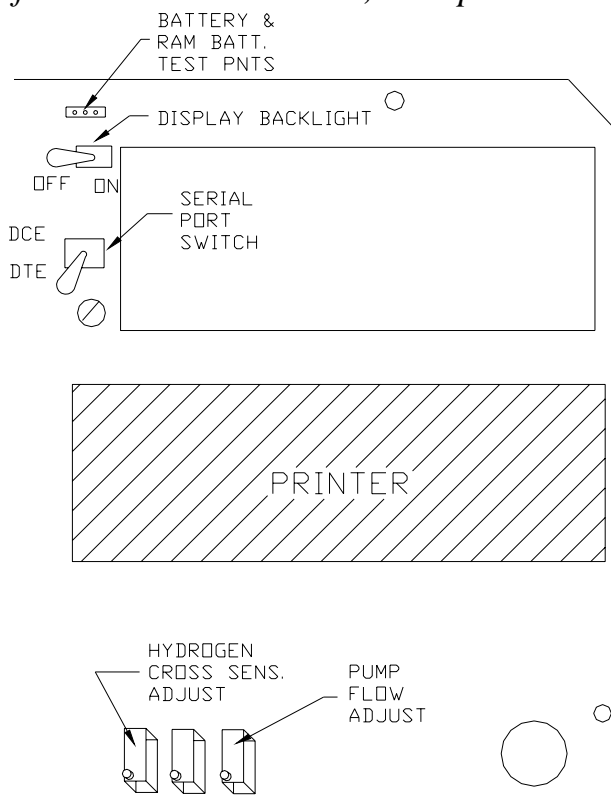

FIGURE 9

The nominal flow rate for the extracted sample is 550 cc/min at room temperature.

The flow rate will be slightly reduced, when the probe is inserted in the stack, because the heated sintered filter's resistance to flow will be increased.

If you observe some condensation during your measurement and wish to reduce the sample flow rate, proceed as follows:

- i. Connect the calibration accessory flow meter to the tip of the probe in such a way as to monitor the instrument flow rate. Record this flow rate.
- ii. Open the hinged section of the face plate. You will see three or

four multi turn potentiometers located on the bottom left side of the printed circuit board.

- iii. The pump flow adjusting potentiometer is the third one on the left. See fig. 9.
- iv. Use a small screwdriver to rotate this potentiometer, while monitoring the Flow meter indication.

To prevent condensation (if already observed), reduce the flow rate by 100 cc/min. Insert the probe in the stack and monitor the clear tubing for 15 minutes. **Remember, do not expose the probe housing to very cold weather and do not insert the probe into stacks where water vapor exceeds 25%, such as down stream of scrubbers.**

- d. **The desiccant drier.** A small quantity of silica gel desiccant is stored inside the probe housing. The purpose of this desiccant is to dry the counterflow air that is introduced into the permeation drier and thus increase the capacity of the permeation drier. There is a small window on the face of the probe housing to check the condition of the desiccant. The desiccant must be replaced, when changes color to pink-white. You can access the desiccant through the threaded plug located at the bottom of the probe housing.
- e. **The LED assembly.** There are five LEDs mounted on the back of the probe assembly. One is green, three are red and the fifth is a bicolor LED that is used for diagnostic purposes.

NOTE (S-V velocity probe): Each time the instrument is turned on or the probe is connected to the analyzer, the four LEDs will turn ON and OFF in sequence to indicate proper initialization of the probe electronics.

During a measurement, you should monitor the LEDs on a periodic basis to make sure that the probe is functioning properly.

REMOVE THE PROBE FROM THE STACK AT ONCE, IF THE "OVERHEATING " LED TURNS ON!

"THE PROBE READY"-GREEN LED monitors the temperature at the drier inlet to make sure that it is sufficiently high to prevent

condensation of the sample. **Insert the probe in the stack, only if this LED is on!** It takes approximately 2-4 minutes for this LED to turn on after a cold start, if the ambient temperature is 65 degrees F. or higher. It may take 10 minutes, if the ambient temperature drops to 40 degrees F. It may take even longer, if the unit is operated on batteries.

"THE FLOW BLOCKED"-RED LED monitors the status of the sintered Hastelloy filter, that is located at the tip of the probe. It also monitors the status of the fiber filter located inside the probe manifold. When either filter becomes excessively dirty and requires cleaning or replacement, this light will turn on.

As the sintered filter is heated in the stack, the pressure drop across the filter will increase from a room temperature pressure drop of 3" to a maximum of 20" W.C. at 1800 degrees F. The instrument pump is capable of pulling a sample with a negative pressure of at least 40". The pressure switch that activates the LED is set for 30" W.C..

"THE NO FILTER OR FLOW"-RED LED is a check against any blockage or kinks in the hose or inside the permeation drier. This light will also turn on, if the sample pump is turned off by means of a suitable command, *OR IF THERE IS NO FILTER AT THE TIP OF THE PROBE.*

If the pressure in the stack exceeds +4" W.C., the "NO FILTER OR FLOW" LED will turn on. You should ignore this LED and proceed with your measurements! This is common in engine measurements, when the ENERAC probe is located in front of a catalytic converter.

"THE OVERHEATING"-RED LED monitors the temperature at the drier inlet to make sure it does not exceed the maximum permissible temperature that the drier can withstand. *For this reason, you must remove the probe from the stack at once, if this light turns on!*

"THE R-HEATING/GR-COOLING" bicolor LED monitors the status of the thermoelectric element and is used for diagnostic purposes, only. When the instrument is turned on, this LED should

always be ON (i.e. RED). When the unit is warmed up this LED will be cycling every few minutes alternating between ON-RED and OFF. Once the probe is inserted in the stack its status will depend on the temperature of the drier manifold. If this temperature becomes high, the LED will turn ON (i.e. GREEN) indicating that the ENERAC heat pump is switched to cooling of the manifold.

3. The hose assembly

The hose assembly consists of a 10 ft. long or longer Viton hose and a power extension cable of the same length. In addition, there is a yellow thermocouple extension cable for the standard probe, or a twisted pair (serial communication cable) for the S-V velocity probe. There are also special gas and electrical connectors. Viton is the material of choice for the hose, because of its inertness and high flexibility. **The ambient temperature sensor is located inside the electrical connector that connects the hose assembly to the instrument face plate.**

NOTE: If the instrument is exposed to the sun are operating for a long time, the ambient temperature indicated may rise a little higher than the room temperature. This does not affect the accuracy of the stack temperature measurement.

B. THE SENSOR HOUSING & PUMP ASS'Y

The ENERAC model 3000E uses the proprietary SEMTM toxic gas sensors that give superior performance to that of the typical electrochemical sensor.

All gas sensors are located inside the instrument. They are mounted for convenience and easy access on a Teflon coated aluminum rectangular block, which is referred to as the "sensor housing" (see figure 10).

To prevent interference with the performance of the sensors, arising from pressure pulsations in the stacks (especially in engine applications), the sensors are located on the exhaust side of the sample pump past a suitable damper assembly. Following the pump and damper, the sample stream enters a section of the sensor housing, where all the toxic gas (i.e. CO, NO, NO₂ and SO₂) sensors and the oxygen sensor are located.

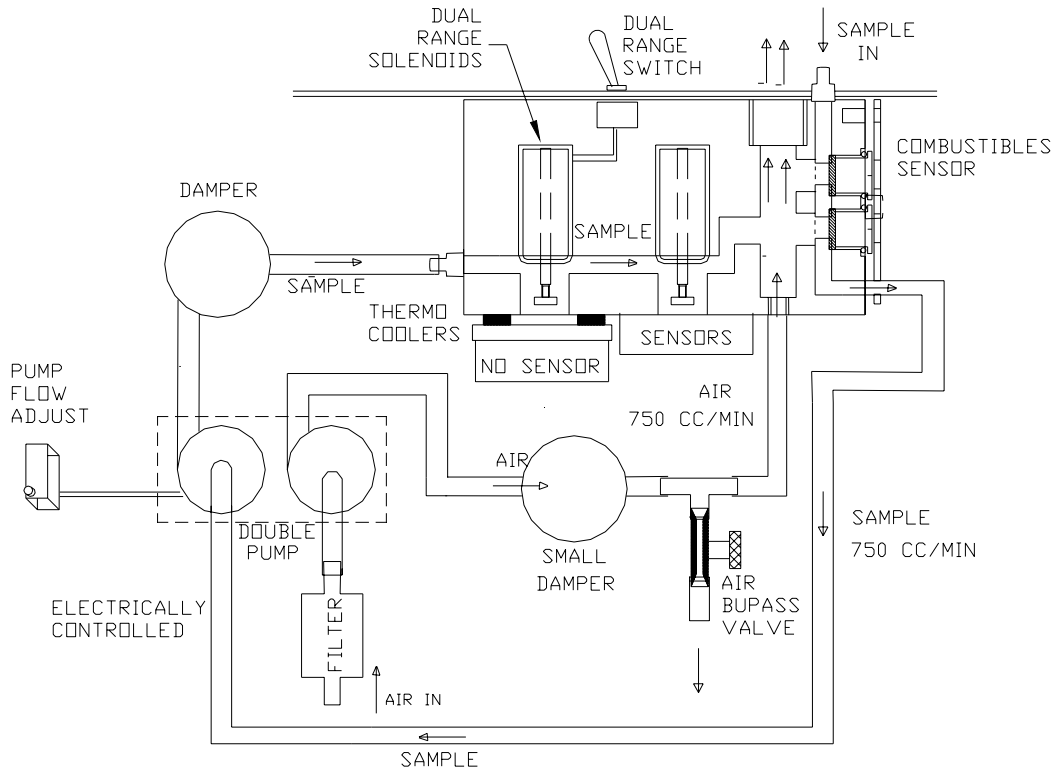

FIGURE 10 COMBUSTIBLES CONFIG.

Please note that all SEM sensors with the exception of the NO_2 sensor are equipped with long life disposable "inboard" filters.

The sample stream is next mixed with an equal amount of air and introduced into the section of the housing, where the combustibles sensor is located. The gas and air mixture is then exhausted in the atmosphere.

1. The pump assembly.

The ENERAC model 3000E pump assembly (IN THE STANDARD COMBUSTIBLES SENSOR CONFIGURATION) consists of the sample pump, two dampers, an air filter and one small screw driver adjustable needle valve. These components, with the exception of a potentiometer that controls the flow rate of the pump, are mounted on a chassis, which in turn is attached to the power supply chassis.

A detailed description of these components follows:

- a. **THE "SAMPLE" PUMP.** This pump consists essentially of two

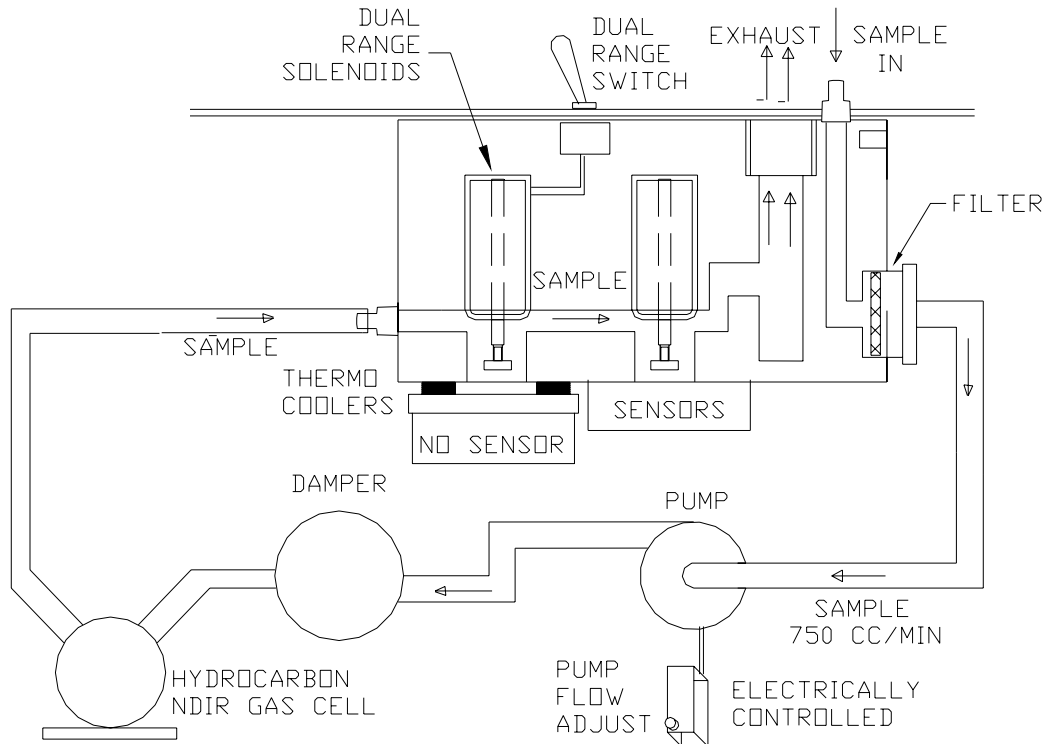

FIGURE 10A NDIR HC OPTION

separate pumps driven by one high quality DC motor. Both pump sections are mounted on one assembly. One pump is used to draw the gas sample into the instrument and the other pump is used to supply an equal amount of air to the combustibles sensor. The nominal flow rate for either section is set at 550 cc/min. By a potentiometer located on the PC board. See figure 9.

The pump used in the optional NDIR hydrocarbons configuration is a high quality single bellows pump using a brushless DC motor for extra long life.

- b. **THE DAMPERS.** There are two damper assemblies. They are both located on the exhaust side of the two pump sections. One (the larger one) dampens the pressure pulsations in the sample and the other the air pulsations. These dampers prevent erroneous sensor responses caused by pressure pulsations from the pump or the stack.
- c. **AIR FILTER.** There are two filters inside the analyzer. A disposable

filter is located on the suction side of the "air" pump section (see figures 10 and 10A). It is used as a precaution, when the instrument is used in a dirty environment. The other filter is mounted on the sensor housing to prevent dirt particles from reaching the pump, if the ENERAC is operated without the probe connected.

- d. **SAMPLE FLOW ADJUST POTENTIOMETER.** This is a small screw driver multiple turn potentiometer located on the printer circuit board as shown in figure 10.
- e. **AIR BYPASS VALVE.** This small brass valve is located on the side of the pump chassis. It can be reached by opening the hinged plate. Its function is to adjust the air flow to the combustibles sensor so that it is approximately equal to the sample flow. (This valve is not used in the NDIR configuration).

2. The sensors

- a. **Temperature sensing.** The instrument uses three temperature sensors. One monitors the stack temperature and the second monitors the ambient temperature outside the instrument case and the third monitors and controls the temperature of the nitric oxide sensor. (For the velocity probe option, a fourth temperature sensor, located inside the probe serves as a cold junction reference for the stack probe thermocouple).
 - i. **THERMOCOUPLE.** The thermocouple is located at the tip of the probe. It measures the stack temperature minus the ambient temperature. The thermocouple junction is a shielded, ungrounded, inconel sheathed, type K thermocouple with a capability of measuring temperatures from 0 to 2000 degrees F. The instrument software linearizes the thermocouple output to improve the accuracy.

On standard units the thermocouple is located inside the extraction probe. On stack-velocity units it is located in the space between the gas extraction probe and the Pitot tube.

- ii. **AMBIENT TEMPERATURE SENSOR.** This is an integrated circuit type temperature sensor. It is located inside the electrical connector, which is at the end of the probe. It is used to measure the room or ambient temperature. For the standard probe, it also represents the cold junction temperature.
- b. **Gas sensing.** All gas sensors are located on or inside the sensor housing. The sensor housing can be accessed by opening the hinged part of the face plate.

Each sensor, with the exception of the nitrogen dioxide sensor, is supplied with two detachable interchangeable precision control modules (PCM), whose function is to select the appropriate measurement range of the instrument. See Table 1.

- i. **The dual range switches.** The ENERAC model 3000E is equipped with the dual range switches for carbon monoxide, nitric oxide and sulfur dioxide. *The dual ranges of the sensors are listed in Table 1.* Figure 10 shows the location of the dual range switches on the ENERAC's face plate.

You operate the dual range switch by pushing the lever in the desired direction to select the appropriate range and then releasing the lever to allow it to return to its center position. The corresponding triangular LED that is lit indicates the selected range for that sensor. The selected range is also indicated on the printout, or on data sent by the serial port. The caret, "hat", (^) symbol appears on the printout following the "CO" or "NO" or "SO2" letters, if the upper range is selected. The purpose of the caret sign or its absence is to obtain a record of the range used during the measurement.

- ii. **CARBON MONOXIDE SENSOR. (SEM™ TYPE SENSOR).** This is a proprietary sealed electrochemical cell incorporating a disposable long life inboard filter and multiple capillary design. It consists of four platinum electrodes in an electrolyte. Carbon monoxide gas diffuses through a tiny capillary located on the face of the Precision Control Module(PCM), which includes

also the interference rejection filter media. It reacts with oxygen present inside the cell to form carbon dioxide. The reaction produces an electric current proportional to the concentration of the gas. Sensor life is estimated at 2 years. A calibration adjustment removes all cross sensitivity to hydrogen gas. See figure 9. This calibration is normally carried out at the factory.

The SEM™ CO sensor of the ENERAC model 3000E is superior to the typical electrochemical type sensor in accuracy, interference rejection and its design for continuous operation.

Its inboard disposable filter has an estimated life in excess of 200,000 PPM-hours.

- iii. **OXYGEN SENSOR.** This is a two electrode electrochemical cell. It has a silver cathode and a lead anode. Oxygen diffuses through a tiny hole and reacts with the lead anode. The reaction produces an electric current. The unit software linearizes the current vs. oxygen response. The cell becomes exhausted when all the lead is consumed. It takes about two years for this to happen.
- iv. **NITRIC OXIDE SENSOR. (SEM TYPE SENSOR WITH TEMPERATURE CONTROL).** This is a proprietary four electrode sealed electrochemical cell. It consists of two sections. One section houses the sensor elements and a temperature sensor.

The other section is the interchangeable Precision Control Module made of aluminum. The sensor section contains a proprietary design consisting of four electrodes made of exclusively noble metals immersed in an electrolyte. Nitric oxide gas diffuses through the tiny capillaries located on the face of the PCM and through the filter media. It reacts with oxygen present inside the cell to form nitrogen pentoxide. The reaction produces an electric current proportional to the concentration of the gas. Sensor life is estimated at 2 years.

The sensor and PCM module are mounted on a special aluminum plate, whose temperature is controlled by two thermoelectric Peltier elements located under the plate. Their function is to maintain a sensor temperature below 25 degrees Celsius in order to limit unpredictable temperature based base line drifts in accordance with the EPA CTM-022 protocol requirements.

The SEM™ NO sensor of the ENERAC model 3000E is superior to the typical electrochemical type sensor in accuracy, interference rejection and its design for continuous operation.

Its inboard disposable filter has an estimated life in excess of 100,000 PPM-hours against sulfur dioxide.

This sensor requires a constant bias voltage for proper operation. This voltage is supplied to the sensor, even when the instrument is turned off. It draws a small amount of current and will drain the batteries completely in about 10 months. For this reason the unit should always be given a fresh charge once every 2-3 months.

NOTE: See Appendix E for the correct determination of the NO and NO₂ fractions of NOX!

- v. **SULFUR DIOXIDE SENSOR.** (SEM TYPE SENSOR). This is an electrochemical cell consisting of two sections also. One section consists of the sensor module that houses the electrodes and electrolyte. The other section consists of the Precision Control Module. A breakthrough in the sensor design eliminates interference from NO₂ gas.

The SEM™ SO₂ sensor of the ENERAC model 3000E is fabricated in a different manner from the typical electrochemical type sensor and is superior in accuracy, interference rejection and its design for continuous operation.

This sensor also requires a constant bias voltage for proper

operation. This voltage is supplied to the sensor, even when the instrument is turned off. It draws a small amount of current and will drain the batteries completely in about 10 months. For this reason the unit should always be given a fresh charge once every 2-3 months.

- vi. **NITROGEN DIOXIDE SENSOR.** (SEM TYPE SENSOR). This is an electrochemical cell that is made of one section only. There is no Precision Control Module or interference rejection filter media for it. It has a standard range of 0 to 500 PPM. Its life is estimated at two years.

NOTE: In addition to the sensor long life filters, the model 3000E emission analyzer uses mathematical compensation techniques to minimize any residual cross sensitivities that its toxic sensors may have to any gases other than those they are intended to measure.

NOTE: The unique multiple capillary design of the SEM sensors makes it easy to change the span range of the instrument and in addition develop true multiple range instruments by changing the sensor's sensitivity and not by just changing the value of the gain resistor in the amplifier circuit.

- vii. **COMBUSTIBLES SENSOR.** (Figure 10)

NOTE: This catalytic type sensor is intended to be used as a detector of dangerous concentrations of unburned gases and is of limited accuracy for the measurements of hydrocarbons. It will also respond to the presence of hydrogen and carbon monoxide, which are combustible gases, but not hydrocarbons. For accurate measurements of hydrocarbons, one must use the NDIR HC option (see below).

This is a two element catalytic type sensor. Any flammable gas in the vicinity of the active element will be combusted with oxygen present and cause a rise in the temperature of the detector element, which is essentially proportional to the heating value of the gas. The rise in temperature causes an increase in the electrical resistance of the element, which in turn is converted to a signal proportional to the gas concentration. For proper operation it is necessary to supply a sufficient

amount of oxygen.

This is achieved by mixing an equal amount of air to the sample gas.

The combustibles sensor will in principle detect any hydrocarbon or organic vapor, hydrogen gas and ammonia. The calibration gas used to span calibrate this sensor is 1% methane balance nitrogen. Of course, any other gas, such as propane may be used to calibrate the unit.

With the ENERAC 3000E calibrated on methane, you can obtain its response to other gases by multiplying the instrument's display reading by the factors listed below:

GAS	MULTIPLY DISPLAY BY
Ammonia	2.38
Acetylene	0.833
n-Butane	0.613
Carbon monoxide	3.125
Ethane	0.833
Ethylene	0.826
n-Hexane	0.565
Hydrogen	0.985
Methane	1.000
Methyl alcohol	1.613
Propane	0.752

The factors listed above are theoretical and should be used as a guide only in determining the response to other gases.

The minimum amount of oxygen available to the sensor is 10-11% (assuming no oxygen in the sample). Consequently, the maximum concentration of methane that can be measured is 6%. For propane the maximum concentration is 2-3% and for octane 1%.

The type of sensor used is not dependent on oxygen concentration, as long as there is sufficient oxygen for the

reaction.

viii. **The NDIR hydrocarbons sensor & assembly** (optional).
(Figure 10A)

A unique option available in the ENERAC 3000E is a state of the art NDIR sensor for the measurement of hydrocarbons based on the USEPA's Reference method 25B.

The NDIR gas cell is mounted on its own PC board and is a unique design employing state of the art infra red LED emitters and dual PBSe detector technology. The power drain to the ENERAC of this option is negligible!

The sensor is calibrated for propane having a range of 0 - 1.000% . However, it can be calibrated to any other hydrocarbon. Its resolution is 0.01% (10 PPM).

The sensor is carefully designed for exceptional temperature stability.

CHAPTER 6

CUSTOMIZING YOUR INSTRUMENT (USING THE "SET" KEY)

The ENERAC Model 3000E gives the operator the capability to customize his instrument to best meet the specific needs of the application.

By customization we describe the process of setting certain parameters such as fuels, degrees F or C, alarm levels, emissions units, plotting coordinates etc. and having to do it only once, without having to repeat such procedures every time the instrument is turned on. This information is stored in the instrument and will be retained, even if all power is removed including the battery.

Of course, any parameters that have been previously set can be changed by the customer by following the procedures outlined below.

When the instrument is turned on for the first time, it assumes a certain configuration (called the DEFAULT CONDITIONS), that was originally stored at the factory. (For example the default CO alarm level is 50 PPM, the default fuel #1 is #2 oil etc.).

A description of how to customize instrument follows.

A. THE "SET" GROUP OF KEYS

To customize your unit you will have to make use of the four buttons located near the top of the face plate. These buttons are labeled "SET", "UP", "DOWN" and "ENTER". See figure 11.

1. The "SET" key.

You use the "SET" button to get in, or get out of the SETTING MODE.

When the LED located directly above the "SET" button is off, you are in the normal measurement mode and all the operating buttons (outside the setting group) function as labeled.

When the "SET" LED is on, you are in the setting mode. The operating buttons assume now the "SETTING" function indicated immediately above or below them. (The action is similar to that of the 2nd function in a calculator).

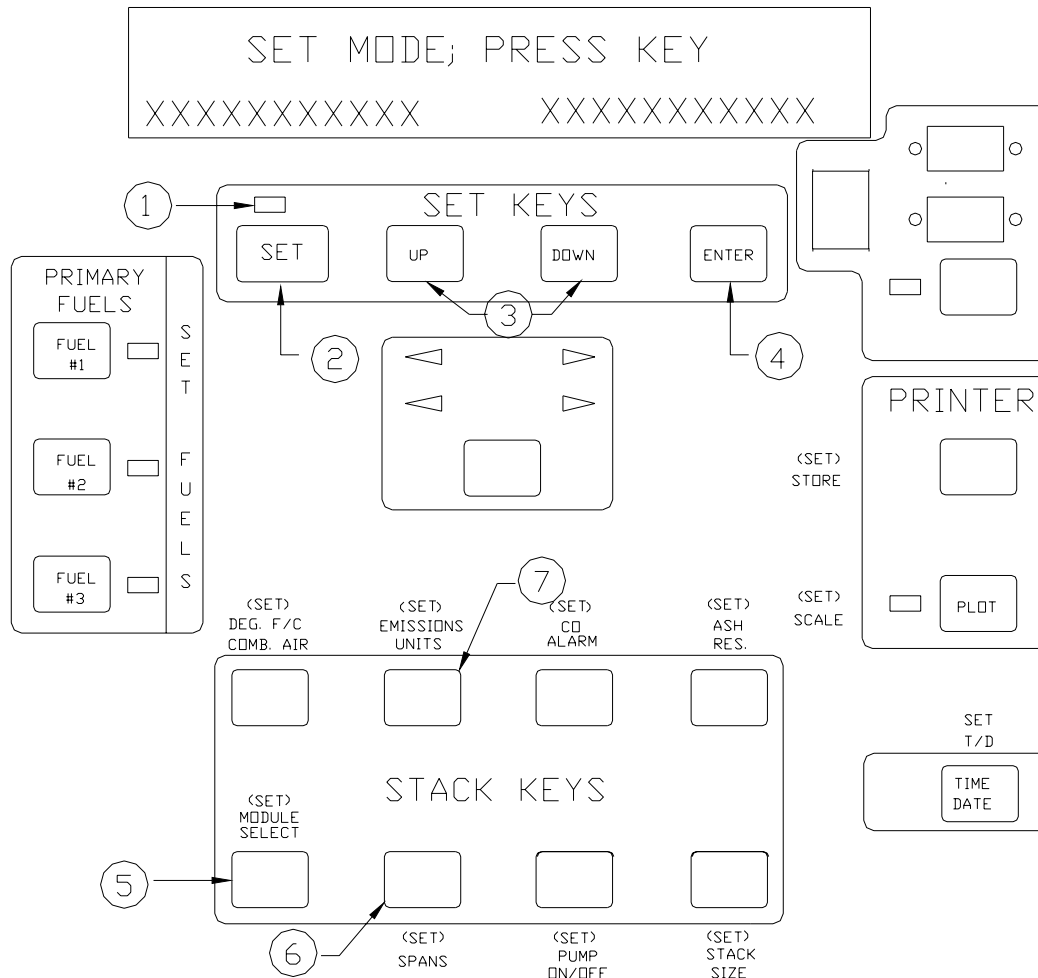

1. LED ON- "SETTING MODE" LED OFF- "MEASUREMENT MODE"
2. "SET" KEY TOGGLES BETWEEN "SET"& "MEASUREMENT" MODE
3. "UP" & "DOWN" KEYS INCREMENT-DECREMENT SET VALUE
4. "ENTER" KEY SHIFTS CURSOR TO THE NEXT DIGIT OR THE SECOND HALF OF THE DISPLAY, ALSO EXITS "SET" MODE
5. USE THIS KEY TO SELECT THE DESIRED PCM- ALL SENSORS
6. USE THIS KEY TO BEGIN SPAN CALIBRATION OF UNIT
7. USE THIS KEY TO SELECT UNITS OF EMISSIONS & OXYGEN REF.

FIGURE 11

To set any one parameter, push the "SET" button. The "SET" LED will turn on and the following message will appear on the display:
You must now press the button corresponding to the parameter you wish to set.



An explanation of the meaning of the operating buttons in the setting mode follows below.

2. The "UP" & "DOWN" keys.

The "UP" and "DOWN" buttons are used to increment and decrement the parameter that you are setting. The increment/decrement interval is preset and depends on the parameter being set. (For example, the inc./dec. interval for setting combustibles in ash is 5%). The range over which a parameter can be set is also fixed.

You can increment/decrement a parameter continuously if you hold down the "up"/"down" button.

You also use the "UP" and "DOWN" buttons not only for changing the numerical entries, but also for selecting various modes. (i.e. You select between STORE, PRINT, DUMP, ERASE, etc when you are in the "SET" " STORE" mode).

3. The "ENTER" key.

When you are in the "SET" mode, the "ENTER" button functions either as a "shift the cursor on the display to the next position" key, or to accept the changes and exit the "SET" mode.

When you are in the setting mode, a blinking cursor will appear on the display in front of the parameter that you are currently setting. However, some functions require the setting of more than one parameter. (For example setting the time/date requires setting the minutes, hours, day,

month etc). Use the "UP" and "DOWN" key to select the appropriate blinking digit or parameter and then use the "ENTER" key to "shift" over to the next digit or parameter that requires setting. You can also use the "ENTER" button to get out of the setting mode ("SET" LED will turn off).

There are two additional specialized functions of the "ENTER" button. If you encounter a "...AUTOZERO ERROR" message during start up, you can use the "ENTER" button to continue with the warm up procedure. (CAUTION: Disregard any display readout of the malfunctioning parameter!). The second application deals with span gas calibration and is explained later.

B. HOW TO SET YOUR FUELS

Selecting the proper fuel is important for the computation of carbon dioxide, excess air and combustion efficiency. The fuel factor enters also in the computation of toxic gas concentrations when expressed in lbs./ million BTU (#/B), grams/ brake hp-hr (GBH), or lbs/hour (#/H).

There is an LED LOCATED to the right of each of the three fuel buttons. The one that is on, indicates the fuel that the machine is currently using to compute efficiency, CO₂ etc.

When the instrument is turned on for the first time, you will have in the foreground the following fuels:

- Fuel #1: #2 OIL
- Fuel #2: #6 OIL
- Fuel #3: NATURAL GAS

These fuels are set at the factory, unless the customer has ordered a custom fuel.

Each time you turn the instrument on, it will default to Fuel #1. Of course, fuel #1 will be the fuel that you have chosen to store in that position.

The instrument has a library of 15 fuels. You can select any three of these fuels and place them in any of the three fuel positions (buttons).

As an example, assume you wish to have fuel PROPANE as Fuel #2. Proceed as follows:

1. Push the "SET" button and observe the "SET" LED turn on.
2. Push Fuel #2 button. The corresponding LED will turn on and the current fuel will be displayed.
3. Scan the Fuel Library by pressing repeatedly the "UP" or "DOWN" buttons, until the following message is displayed:

PROPANE	21680	BTU/LB
Up/Down-Change; Enter-OK		

4. Push the "SET" or "ENTER" button and observe the "SET" LED turn off. PROPANE is now fuel #2 and you are back in the normal measuring mode.

The fuels that the fuel buttons are set for, are retained even after the instrument has been turned off, so that you will not have to repeat any setting procedure every time you turn the unit on.

C. SELECTING THE TEMPERATURE SCALE

The instrument can be set to display and print all temperatures either in degrees Celsius or Fahrenheit.

It can also compute the combustion efficiency for boilers that use combustion air that is at a temperature different from the ambient temperature (such as preheated air). The efficiency formula takes into account the energy of the preheated air, in order to give a more accurate computation of the actual combustion efficiency.

If your combustion air is at approximately ambient temperature , leave the combustion air setting to its default value of "ambient".

The adjustment range for combustion air is 0 degrees to 260 deg. C or 32 to 500 deg. F.

To change the temperature scale (F or C) proceed as follows:

1. Push the "SET" button and observe "SET" LED turn on.
2. Push the "TEMP/ST-RM" button. The following message will be displayed:

**COMB. AIR AMB; SCALE F
Up/Down-Change; Enter-OK**

3. Push the "ENTER" button. The blinking cursor will shift to the letter F (or C).
4. Push the "UP" or "DOWN" button once. The letter F will change to C (for Celsius).
5. Push the "SET" button to get out of the setting mode.

If you use preheated air, first take its temperature using the stack probe. As an example, assume the preheat air temperature is 372 degrees F.

1. Push "SET" button and observe "SET" led turn on.
2. Push the "TEMP/ST-RM" button. The following message will be displayed:

**COMB. AIR XXX; SCALE F
Up/Down-Change; Enter-OK**

3. Use the "UP" button until the display reads:

**COMB. AIR 370; SCALE F
Up/Down-Change; Enter-OK**

4. Push the "SET" button again to exit the setting mode.

Remember to reset your preheat temperature back to "AMB"., if the unit is going to be used in different conditions!

D. EMISSIONS MEASUREMENTS

If you press the "SET" and "OXYGEN" keys in sequence, you will be in the "emissions" SET mode. The following two messages will be displayed:

**MODE:PPM OXY_REF:TRUE
Up/Down-Change; Enter-OK**

The message "MODE: PPM" refers to the desired "MODE" selection (i.e. the units of measurement selection) and means that the toxic gas sensors (i.e. emissions sensors, carbon monoxide, nitric oxide, nitrogen dioxide, NOX computation and sulfur dioxide) will read the respective gas concentrations in parts/million by volume.

The display "TRUE%" indicates that there is no correction for oxygen and the readings will be actual concentrations. This is the DEFAULT setting from the factory.

Note: Do not use OXY_REF:0%, if you require no oxygen reference correction! Use instead OXY_REF: TRUE%!

There are two functions of the "SET EMISSIONS" key.

1. Selection of measuring units.

You can select to read the three toxic gas concentrations (CO, NO, NO₂, SO₂ AND ALSO NOX) in any of the following units:

PPM ----- Parts/million (Volumetric)- dry basis
MGM ----- Milligrams/cubic meter - dry basis
#/B ----- Lbs./ million BTU of fuel - dry basis
GBH ----- Grams/ brake horsepower-hour - dry basis

For instruments equipped with the stack-velocity (S-V) option, you can also measure emissions in the following units:

#/H ----- Lbs/ hour - wet basis
(T/D) ----- Tons/day (carbon dioxide only!) - wet basis

NOTE: Emission units measurements in PPM, MGM, #/B and GBH are carried out on a dry basis as required by the EPA's 40CFR75 . (The ENERAC is an extractive analyzer, whose conditioning system removes most of the water vapor before the sample reaches the sensors). Emission units measured in #/H and T/D (for CO₂) are displayed on a wet basis by accounting through computation of the amount of moisture in the stack, as required by the EPA's 40CFR75 regulations!

NOTE: NO and NOX emissions in #/MBTU, GBH and #/H are computed as NO₂!

NOTE: Values of emissions in #/MBTU , GBH and #/H are fuel and CO₂ dependent. The fuel parameters for certain typical fuels (i.e. the F- factors for anthracite etc.) used in the model 3000E have been modified to be identical to those specified in 40CFR60 Appendix A method 19 of the code of federal regulations.

Consult Enerac, Inc. for details and correction factors.

To choose the desired emission units toggle the "UP" button until the proper units are displayed. Exit the "SET" mode.

If you select GBH (grams/brake horse power-hour) as the desired units, the ENERAC will, after pressing the "ENTER" key display the following message:

**ENGINE THERMAL EFF:0.30%
Up/Down-Change; Enter-OK**

You must enter the engine's thermal efficiency (typically a number between 0.25 and 0.35). You can obtain this figure from the engine's manufacturer specifications. It differs somewhat as a function of engine type and load factor.

The ENERAC's default value is 0.3.

If the thermal efficiency is not known, it may be computed by using the engine's BSFC (brake specific fuel consumption-BTU/BHP-HR) as follows:

ENGINE EFFICIENCY = 2547/BSFC

After entering the desired thermal efficiency value (*THIS FIGURE IS NOT THE ENERAC'S COMBUSTION EFFICIENCY!*), the ENERAC will display emissions in grams/brake horsepower-hour.

If the analyzer is equipped with the S-V velocity probe, you can compute the emission rate (lbs/hour, for toxic gases; tons/day for CO₂).

NOTE: Make sure the correct stack size has been entered into the ENERAC, when you are displaying mass emission rates! Make sure the probe is held with the pitot tube openings exactly parallel to the direction of the flow of the stack gases. You may wish to take a number of measurements across the stack cross section for greater accuracy (see EPA 40CFR60 App. A Method 1 for proper EPA approved measurements!).

2. Selection of Oxygen (reference) Correction factor.

Many environmental regulations require that the concentrations of pollutants measured, be corrected to some reference value of oxygen other than the actual concentration at the time of the measurement. Typical oxygen reference values are 0% (air free), 3%, 7% or 15%.

To select the desired oxygen reference value enter the "SET EMISSIONS" mode as described above. Press the "ENTER" key so that the cursor blinks on the OXY_REF side of the display. Toggle the "UP" or "DOWN" button, until the desired value of the reference oxygen is displayed. (Range is 0-20% in 1% increments).

To return to uncorrected measurements, depress the "UP" button until the display reads: OXY_REF: "TRUE%".

NOTE: Setting the OXY_REF to a value other than "TRUE" affects values of emissions concentrations in PPM and MGM. It does not affect values in #/B, GBH or #/H!

Return to the measurement mode by pressing the "ENTER" key once more and observing the "SET" LED go off.

The oxygen reference will always return to “TRUE” when the instrument is turned on, to prevent accidental measurement errors on emission parameters.

E. SETTING THE CO ALARM

The instrument is provided with an audio and visual alarm that will be activated, if a preset threshold of carbon monoxide is exceeded.

The audio alarm consists of a beeping sound occurring every second to alert the user. The visual alarm consists of the simultaneous flashing, of both display pointer LEDs.

To set the CO alarm proceed as follows:

1. Push the "SET" button and observe the "SET" LED turn on.
2. Push the "CO/SO2" button. The following message will be displayed:

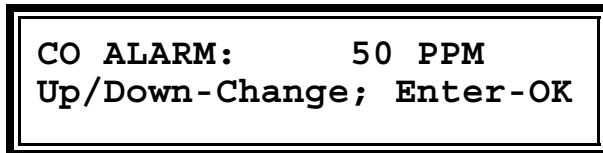

CO ALARM: 50 PPM
Up/Down-Change; Enter-OK

3. Use the "UP and "DOWN" buttons to set the alarm threshold to your desired value.
4. Push the "SET" button to exit the setting mode.

NOTE: If you have the emissions option, your CO ALARM function will always be set for the same units as those selected for measuring the toxic gas (emissions) concentrations!

F. SETTING THE COMBUSTIBLES IN ASH

When solid fuels such as coal are burned, they leave a residue called ash. Ash drops through the stoker gratings to the bottom of the boiler. However, some unburned fuel also drops through the grating and is discarded with the ash. This unburned fuel represents potential energy that has not been utilized. The ENERAC model 3000E will take into account this loss of energy in its efficiency formula, if

the % of unburned fuel in the ash residue is entered into the instrument.

You need a special instrument to measure the % Combustibles in ash!

The default value of combustibles in ash is zero.

The combustion efficiency for gaseous, liquid and wood fuels is not affected by any setting of the combustibles in ash parameter, since the instrument assumes that there should be no ash with combustibles for such fuels.

The combustion efficiency for all coal fuels listed in the fuel library will, however, be affected, if you set the combustibles in ash to a value other than zero. Be careful to remember, that when you are setting combustibles in ash for a certain fuel you are also setting the same value for all coal fuels.

To set the combustibles in ash proceed as follows:

1. Push the "SET" button and observe "SET" LED turn on.
2. Push the "COMBUSTIBLES" button. The following message will be displayed:

COMB IN ASH: 0% Up/Down-Change; Enter-OK
--

3. Use the "UP" and "DOWN" buttons to set the display to the desired value of combustibles in ash.
4. Push the "SET" button to exit the setting mode.

G. SELECTING THE INSTRUMENT RANGE

This function should be used, only if you are changing the analyzer's basic range by replacing the existing PCM, if "LOW" with a "MID" and vice versa.

You press the "SET" and "X-AIR/CO2" keys in sequence to select the proper PCM range for your emissions measurements! See chapter 3 for details.

H. SETTING THE SPAN CALIBRATION

The sequence of keys “SET”, “NO/NO2” is used to perform span calibrations of the gas sensors.

See chapter 12 of this manual for a complete description of how to set the span and carry out a calibration of the unit using span gas.

I. TURNING THE PUMP ON / OFF

If you wish to turn the ENERAC's main sample pump off, enter the "SET" mode and next press the “EFFI/VELO” key. The sample pump will stop and there will be no sample flow to the ENERAC. This action prolongs the ENERAC's filter life, when the instrument probe is mounted on the stack but no measurements are being taken. The air counter flow pump located inside the probe will keep running.

Press the same key again to start the pump.

J. SELECTING THE STACK SIZE & FLOW RATE UNITS (stack-velocity option)

If your ENERAC is equipped with the stack-velocity (S-V) option, you can select to measure the velocity of the stack gases, either in units of feet per second (F/S) or in units of cubic feet per minute (CFM).

Measurement in CFM requires knowledge of the cross sectional area of the stack. In addition, for emission rate measurements (lbs/hour - #/H) you must set the size to the correct stack cross section area measured in inches square.

To set the stack size, proceed as follows:

1. Determine the area of cross section of the stack where the ENERAC's probe is located.

Press the “SET” and “EFFI/VELOC” keys in sequence. The following message will appear on the display:

```
SIZE= XX IN2,UNITS:CFM
Up/Down-Change;Enter-OK
```

Where,

XX is the cross section of the stack in units of square inches.

The range of allowed stack sizes is 4-10000 sq. in.

CFM is the assumed currently selected units of stack gas flow rate, either F/S (feet/second) or CFM (cubic feet /minute).

3. Use the “UP” or “DOWN” key to set the correct stack size.

Entering the correct stack size is important, because it is used in the calculation of CFM and emission rates in units of lbs/hour.

4. Use the “ENTER” key to shift the cursor to the flow position to the UNITS
5. Use the “UP” or “DOWN” key to select the desired units of velocity. Press the “ENTER” key to accept the changes. The following message will appear next on the display:

```
PITOT COEF: 0.84
Up/Down-Change;Enter-OK
```

Where,

PITOT COEF is the value of the pitot coefficient that will be entered in the velocity calculations. For an S type pitot tube, such as is supplied by the ENERAC probe assembly, **make sure this coefficient is set to 0.84** !(unless you carry out an S type pitot tube calibration as per Method 2, Appendix A, 40CFR60. For a **standard type pitot tube** (not supplied by ENERAC) such as you might wish to use to carry out EPA Method 2C reference measurements for small ducts (see chapter 12), **set the value of the pitot coefficient to 0.99.**

Press the “ENTER” key to exit the “SET” mode.

NOTE: The computation of mass emissions in lbs/hour do not depend on whether

the velocity is set for ft/sec or CFM.

K. SETTING THE TIME & DATE

The instrument's internal clock displays and records time (24 hour mode only) in hours, minutes and seconds. It displays and records the date in the American convention of month #, day #, year#.

To set the time or date proceed as follows:

1. Push the "SET" button and observe "SET" LED turn on.
2. Push the "TIME/DATE" button. The following type of message will appear on the display as an example:

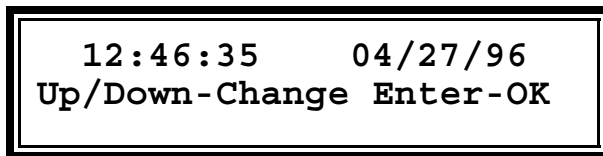

3. Use the "UP" or "DOWN" buttons to set each digit to the correct value and then use the "ENTER" button to shift to the next digit. (If you make a mistake and have to go back to a previous digit you must restart the procedure).
4. Push the "SET" button to exit the setting mode at any time, or the "ENTER" button at the end of the last digit.

L. SETTING THE PLOTTER PARAMETERS

(ALSO SETS THE ANALOG OUTPUT VOLTAGE SCALES)!

1. Setting the ordinate.

There are three vertical scales (ordinates) that can be chosen from in the printer's plotter mode. These scales are numbered:

SCALE: H for Full Range (0-100% of max. reading).

SCALE: M for Middle Range.

SCALE: L for Low Range

The full scale values (100%), (i.e. SCALE H), and also the M and L scale values of the stack parameters for the **standard range model 3000E** are shown on table 2:

MEASUREMENT PARAMETER	HIGH RANGE	MID RANGE	LOW RANGE
Ambient temperature (F or C)	200	100	50
Stack temperature (F or C)	2000	500	200
Oxygen (%)	25.0	12.5	6.25
Combustibles (%)	2.5	1.25	0.625
CO, NO, NO ₂ , NOX, SO ₂ (PPM, MGM)	10000	2000	500
Emissions (#/B, GBH, #/H)	100.00	10.00	1.00
Carbon dioxide (%)	40.0	20.0	10.0
Excess air (%)	1000	500	250

TABLE 2

Use the lower ranges to increase the sensitivity of the plot, provided the parameter you are recording does not exceed the maximum value of the ordinate. (Example: If stack temperature is in the 300-700 degree F range, use scale M. If oxygen is less than 5%, use scale L).

NOTE: Please, remember, that setting the plot scale to one of the three ranges, H, M, or L also automatically sets the scale (i.e. 5 Volts) for all the analog the analog output voltages .

2. Setting the chart speed.

The chart speed (actually its reciprocal) can be selected in units of seconds

per event. (An event will be recorded by a dash on the paper). The fastest chart speed is 1 event/sec. and the slowest 1 event/min. There are 59 intermediate charts speeds to choose from. (Example: A chart speed of 20 means a dash will be plotted every 20 seconds).

To set the desired plotter scale and speed for the chosen stack parameter proceed as follows:

- a. Push the appropriate button, so that the desired parameter is displayed on the display and the "DISPLAY SELECTOR" LED points to it.

You can obtain plots only of the parameters listed on table 2!

- b. Push the "SET" button and observe the "SET" led turn on.
- c. Push the "PLOT" button. The following message will be displayed:

SCALE (PL-ANL) :H TIME 1s
Up/Down-Change Enter-OK

and the cursor will blink at the scale position (i.e. H - high range in this example). The word "PL-ANAL" is a reminder that this setting sets the scale of both the ENERAC plots and the ENERAC analog outputs (i.e. 5.0 Volts).

- d. Use the "UP" or "DOWN" buttons to select among the three scales H, M or L. then use the "ENTER" button to shift the cursor to the time position.
- e. Use the "UP" or "DOWN" buttons to select the desired chart speed (measured in seconds elapsed between events or dots).
- f. Push the "ENTER" button to exit the setting mode.

M. DATA STORAGE

Press the "SET" and "TEXT" keys in sequence to store data or retrieve data from the ENERAC. See chapter 8 for an explanation of how to use the "STORE" button.

CHAPTER 7

USING THE PRINTER

The ENERAC model 3000E is equipped with a 4" SEIKO thermal printer. This printer serves a number of functions that will be described below.

Dust will easily damage the printer! Avoid exposing the printer to a very dusty environment! Use the protective piece of "Velcro" to cover the slot even when using the instrument.

To avoid damaging the printer heads, do not use any ordinary paper or thermal paper, other than the one supplied by Enerac. (Use SEIKO thermal paper only). Thermal paper is a specially treated paper and must be protected from excessive heat or moisture. See the section on maintenance.

There is a special opto-coupler sensor mounted on the back of the printer that monitors the existence of printer paper. If there is no paper in the printer, the message:

"PROBLEM WITH THE PRINTER"

will appear on the display and the printer will not operate.

There is a single push button switch located on the hinged side of the face plate that is used to advance the paper. Depress the "PAPER FEED" switch to advance the paper one line at a time.

There are five different types of printouts that you can get from the printer. (i.e. there are five different ways to use the printer). These are described below.

A. PRINTOUT OF STACK DATA

This is the most basic printer operation. By depressing the "TEXT" key, you get a printout of all stack parameters together with the time, date and fuel description. The values printed are those last read by the instrument *at the moment that the "TEXT" button was depressed.*

To obtain a "current" printout proceed as follows:

1. Make sure that the "SEND LED" is off . If it is not, use the "SEND" button to toggle the "SEND" LED on.
2. Make sure that you ARE NOT in the setting mode ("SET" LED is off).
3. Push the "TEXT" button. The printer will start operating. It takes about 20 seconds to complete the printing.
4. Use the "PAPER FEED" switch to advance the paper, so that it can be easily cut.

An example of a typical ENERAC printout is shown below:

```
SERIAL # ABC123XX
ENERAC MODEL 3000E
COMBUSTION TEST RECORD

FOR: YOUR COMPANY'S NAME

TIME:02:19:96
DATE:05/20/96

FUEL: #2 OIL    19360 BTU/LB

COMBUSTION EFFICIENCY:    77.2%
AMBIENT TEMPERATURE:    68 F
STACK TEMPERATURE:    650 F
OXYGEN:    5.0%
CARBON MONOXIDE: (M)    78 PPM
CARBON DIOXIDE:    11.8%
COMBUSTIBLE GASES:    0.0%
EXCESS AIR:    29%
NITRIC OXIDE: (L) ^    430 PPM
NITROGEN DIOXIDE:    55 PPM
NOX (NO+NO2):    485 PPM
SULFUR DIOXIDE:    80 PPM
STACK GAS VELOCITY:    1500 CFM
NOX CONTROL TEMP: UNDER 30 C
MODE:PPM OXY_REF=TRUE%
```

Please note the following marks on the printout, which are important for record keeping purposes:

1. The letters "L" and "M" in parentheses following the words carbon

monoxide, and nitric oxide indicate that the “LOW” and “MID” range PCMs are mounted on the respective sensors.

- 2. The caret sign “hat” (i.e. ^) following the words nitric oxide indicates that the dual range switch for this parameter had been set to the upper range position for this measurement.*
- 3. The statement “NOX CONTROL TEMP. UNDER 30 C” indicates that the nitric oxide sensor temperature (monitored separately) is below 30 degrees C, a requirement of EPA’s method CTM-022 to prevent excessive zero drift.*
- 4. The statement “OXY_REF=TRUE%” indicates that the CO, NOX and SO2 concentrations measured in PPM are the true stack concentrations and have not been adjusted for some oxygen reference value.*

While the printer is in the process of printing you may use any other buttons to display any parameters you desire.

The basic function of the "SEND" button is to direct information either to the printer or to the output connectors (RS-232 or Modular phone connector).

You cannot direct information simultaneously to printer and outputs!

B. OBTAINING PRINTER PLOTS

See chapter 5 for a description of how to set the plot parameters.

You can use the printer as an analog chart recorder to obtain a continuous plot of any stack parameter vs. time. The printer prints horizontal bars, so that the printout looks more like a step chart rather than one continuous line. The resolution of the vertical scale is better than 1% of full scale (i.e. there are 120 different positions for the bar mark).

There are three vertical scales available and sixty chart speeds ranging from 1 dot/sec to 1 dot/min. See chapter 6 section I for directions on setting the plotter scales.

The plot always begins with a printout of the time and date, followed by the

parameter being plotted, the chart speed and the vertical scale.

To get a time plot of nitric oxide (NO) proceed as follows:

1. Select the proper scale and chart speed, by using the "SET" button as explained in chapter 6, section L.
2. Press the "NO/NO2" key and make sure that "NO: 430 PPM" (in this example) appears on the display. Make sure the display pointer points to the nitric oxide section of the display.
3. Push the "PLOT" button. This will start the plot.
4. When you wish to stop the plot, push the "PLOT" button again.

An example of a single time plot is shown below:

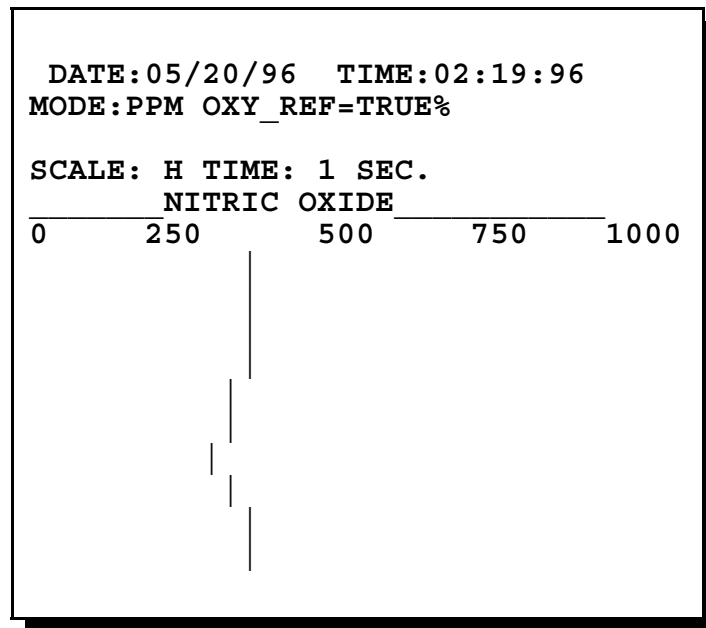

The instrument remembers the last plotting scale and chart speed used even after it has been turned off. It will use the same settings the next time you do a plot, unless you change the settings.

When using the fast speeds, keep in mind that the instrument needs 20-30 seconds to respond fully to any changes to the stack parameters.

C. PRINTING STORED DATA

The instrument is capable of storing the complete results of up to fifty different sets of measurements (see chapter 8). These fifty storage compartments are called buffers (the display calls them TEST#XX) and are numbered from 1 to 50.

You can get a printout of any one stored measurement (i.e. TEST), or you can get a printout of all fifty stored measurements sequentially, if you wish.

If you wish to get a printout of one stored measurement (for example data stored in buffer #7), proceed as follows:

1. Make sure the "SEND" LED is off. (If it is not, use the "SEND" button to turn it off).
2. Push the "SET" key to turn the "SET" LED on.
3. Push the "TEXT" button. This will activate the storage mode (as long as the "SET" LED is on) and the following message will appear on the display:

```
TEST# 1      FUNC= STORE
Up/Down-Change Enter-OK
```

4. Use the "UP" or "DOWN" key to set the Test# to the desired value (7 in the example). Display reads:

```
TEST# 7      FUNC= STORE
Up/Down-Change Enter-OK
```

Push the "ENTER" button to shift the blinking cursor to the right side of the display.

5. Push the "UP" button a few times until the display reads:

```
TEST# 7      FUNC= PRINT
Up/Down-Change Enter-OK
```

6. Push the "ENTER" button. The printer will start printing the data stored in buffer #7.

If you wish to obtain a complete printout of all the fifty tests at once, proceed as follows:

1. Carry out steps 1,2 and 3 outlined above.
2. Push the "ENTER" button to shift the cursor to the function area.
3. Use the "UP" button a few times until the display reads:

TEST# 1 FUNC=PRNT ALL Up/Down-Change Enter-OK

4. Push the "ENTER" button. The printer will start printing in sequence all data stored in the buffers.

REMINDER: The printer WILL NOT PRINT any buffers (i.e. test#) that are EMPTY.

D. PRINTING MESSAGES

The ENERAC model 3000E is designed to communicate with external devices such as computers or terminals. During such communication it may be important (especially when communicating by telephone), for the remote computer operator to send messages or instructions to the operator of the instrument.

After establishing communication via either the RS-232 port or the modular phone connector you can have your messages printed by the ENERAC printer by sending the PRNT command followed by quotation marks, then the desired message ending with marks. For examples if you send the message:

PRNT "REDUCE EXCESS AIR TO 30%"

the printer will print:

REDUCE EXCESS AIR TO 30%

You can send to the printer up to 40 characters at a time with each PRNT

command.

E. CALIBRATION PROTOCOL PRINTOUTS

One of the most important functions of the ENERAC's printer is the automatic printing of the "ENERAC CALIBRATION PROTOCOL".

This protocol is activated and the results printed, every time the ENERAC undergoes an AUTOZERO or a SPAN GAS calibration.

The purpose of this protocol is to make sure that the instrument and especially its sensors and sensor filters are in good condition and thus, maintain data integrity.

A detailed explanation of the "ENERAC CALIBRATION PROTOCOL" is given in the "CALIBRATION" chapter 13 of this manual.

CHAPTER 8

STORING YOUR MEASUREMENTS

You can save the results of a combustion or emissions performance test by using the storage capabilities of the ENERAC model 3000E. This is a very useful feature, especially if you have to test a number of combustion sources in sequence, or you wish to compare previous with current measurements. You can also dump the emission data to another computer.

The information that you save, will be retained in the instrument's memory, even after the instrument has been shut off. It will be retained, even if the battery is removed from the unit

Of course, you have the capability of erasing any test results, that you no longer need and replacing them with new ones.

If you plan to do a lot of data storing, you may wish to consider as an alternative using the ENERCOM™ for WINDOWS software together with a notebook or laptop computer. This option gives much greater flexibility in selecting and storing data.

You can store up to fifty different test results (i.e. sets of data) in the instrument's memory. These are defined as :

TEST#1 through TEST#50.

Each test contains complete information on all stack parameters including date and time, exactly as they would appear, if you had obtained a printout by pushing the "TEXT" button. In addition, it includes the SOURCE I.D. # that you entered before storing the test.

NOTE: Source identifications are entered into the ENERAC only through the serial port command "SRCE". See the COMMANDS chapter.

A. THE STORAGE FUNCTIONS

The storage function can perform the following ten operations:

1. **“STORE”** This operation will store all the current values and source identification number. These will be stored in the test (storage) compartment whose number appears currently on the display (provided it is empty!).
2. **“START P.”** This operation will cause the ENERAC to erase all existing data from its storage buffers and begin storing data in its buffers sequentially on a periodic basis.
3. **“STOP P.”** This operation will end the periodic storing of data initiated by the “START P.” command.
4. **“DUMP”** This operation will send to the RS-232 output the contents of the test# that is currently appearing on the display. (If you have an internal modem and you have established a telephone link, the information will be sent to the modular phone connector).
5. **“DUMP ALL”** This operation will send to the RS-232 output, or to the modem, the entire contents of all eighty tests stored, in sequence. The instrument will ignore any empty storage buffers.
6. **“PRINT”** This operation will cause the printer to print the contents of the test whose number appears currently on the display. (If it is empty, nothing will be printed).
7. **“PRINT ALL”** This operation will cause the printer to print the contents of all seventy five tests, in sequence starting with test#1. The instrument will not print empty storage locations.
8. **“ERASE”** This operation will permanently erase the contents of the test whose number appears currently on the display. You cannot overwrite a used test# (i.e. if there are data stored

in that buffer, you must erase it first).

- 9. **“WIPE ALL”** This operation will erase permanently the contents of all fifty storage locations.
- 10. **“QUIT”** This operation takes you out of the storage function, without executing any of the above functions.

B. HOW TO STORE THE DATA

Figure 12 shows a chart of the required sequence of operations for storing in the ENERAC's memory.

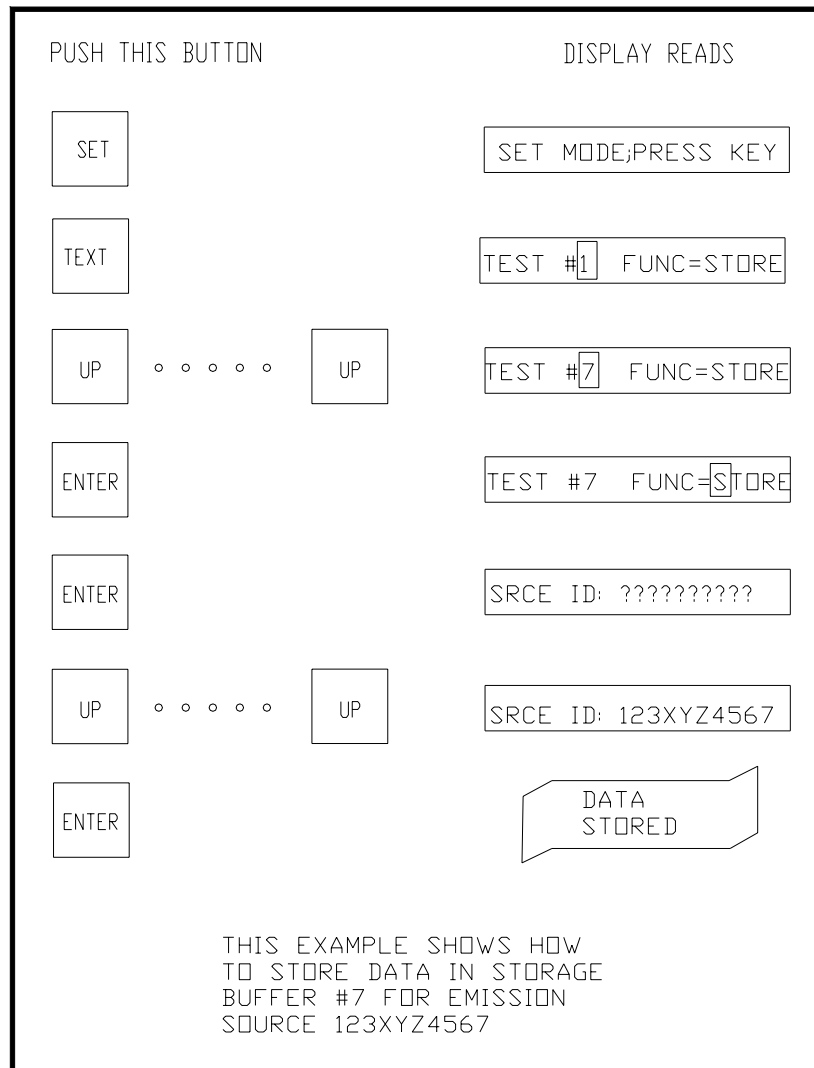

Figure 12

To store a single complete combustion test in the ENERAC's memory proceed as follows:

1. Push the "SET" button and observe "SET" LED turn on.
2. Push the "TEXT" button. The following message will appear on the display:

```
TEST# 1      FUNC= STORE
Up/Down-Change Enter-OK
```

3. Use the UP/DOWN buttons until the desired TEST # appears on the display. (You can select up to 50 different tests).
4. Push the ENTER button to shift the blinking cursor to the letter "S" of the function STORE.
5. Push the ENTER button again. The display will read:

```
SRCE ID: XXXXXXXXXXXX
Up/Down-Change Enter-OK
```

6. Use the UP/DOWN buttons until the source identification associated with the emission source under test appears on the display. (You have a selection of 50 different source identification ten digit alphanumeric entries to choose for the emission source that you are currently working with. Enter the correct one corresponding to that source! You should have already programmed the source identification entries into the ENERAC through the appropriate serial port command).
7. Press the ENTER button again. The current stack parameters will be instantly stored in memory. The instrument exits the SET mode.

NOTE: An operator taking emission measurements from a number of different sources, will want to enter all the source id's using a computer, before starting his measurement rounds. At a certain source he will store emission data by selecting first an unused "TEST# ". He will then scroll through his source id's by using the "UP or "DOWN" buttons until he finds the source id corresponding to the selected combustion source. He will then press the "ENTER" key to store his current emission data. These data can be printed or downloaded and the 10

character alphanumeric source identification will appear together with the data.

C. RECOVERING STORED DATA

You can recover your stored combustion tests, either by having them printed on the ENERAC's printer or by sending them out via the RS-232 port or the telephone line.

To recover your data proceed as follows:

1. Push the "SET" button and observe "SET" LED turn on.
2. Push the "TEXT" button. The following message will appear on the display:

```
TEST# 1      FUNC= STORE
Up/Down-Change Enter-OK
```

3. After selecting the proper TEST# (if you wish to recover only one test result), press the ENTER button to move the cursor over to FUNC location.
4. Use the UP/DOWN buttons until one of the following functions appears on the display: "DUMP", "DUMP ALL", "PRINT", "PRINT ALL".
5. Press the ENTER button. The stored result, or results will be sent to the selected output device.

D. PERIODIC STORAGE

You can store data periodically in the ENERAC's internal storage buffers, by entering the "SET", "STORE" key strokes. Press the "ENTER" key to shift the cursor to the right hand side of the display. Press the "UP" or "DOWN" keys until the message "START P." is displayed. Press the "ENTER" key. The following message will appear on the display"

```
ENTER STORE PERIOD XXMIN
Up/Down-Change Enter-OK
```

You can select any period to store your data from 6 to 60 minutes by using the “UP” or “DOWN” keys. Press “ENTER” to begin periodic storage.

The following message will appear on the ENERAC display every few seconds to alert you that you are storing data periodically:



NOTE: When you begin the periodic data storage, the ENERAC will wipe all previous data stored in its memory and will store the periodic data starting with buffer #1.

Next data will be stored in buffer #2 etc. If all buffers are become filled, it will stop storing data. If you turn the ENERAC OFF and then ON again periodic storage will stop automatically.

To stop periodic storage at any time press “SET”, “STORE” “ENTER” and then “UP” until “STOP P.” appears on the display. Press “ENTER” periodic storage will be discontinued.

E. ADDITIONAL STORAGE

Because of the ENERAC's capabilities, you are not limited to storing only the results of 50 tests. You can use the RS-232 output to connect to an outside computer.

The most convenient way to obtain unlimited storage capability is to use the ENERAC'S ENERCOM™ FOR WINDOWS software with any PC computer using Windows 95 or higher.

Some of the capabilities of this software include:

1. Calculation of maximum, minimum and average values over a pre selected period.
2. Storage and retrieval of data and plots from the computer in a variety of formats.
3. Programming custom fuels into the ENERAC.

4. Obtaining multiple plots & bar graphs.
5. Letting multiple alarms and monitoring their duration.
6. Entering the emission source identification alphanumeric digits

CHAPTER 9

COMMUNICATIONS

One of the most important recent developments in portable instruments is their ability to communicate directly with other instruments or computers. When good communications capability is paired with the development of artificial intelligence, the result is a very powerful system that can literally replace a consultant's visit to the plant and assure optimum performance of the monitored equipment at all times.

The ENERAC model 3000E has been designed with this concept in mind. It is capable of communicating directly with a computer in any of the following ways:

1. Through its RS-232 port.
2. Through the telephone line by using the modular phone output.
3. Through its analog output port.

Enerac is a leading innovator in the field of combustion emissions measurements and is committed to this concept and will be introducing so called "Expert Programs" that will be able to perform remote diagnosis and recommend steps to improve boiler performance.

We strongly recommend using the ENERCOM™ FOR WINDOWS program to communicate with any computer that is equipped with Windows™ software. This program offers unlimited storage capacity, automatic computation of maximum, minimum and average values over customer specified periods, presettable alarms and duration for any parameter, programming custom fuels, displaying bar graphs of the emission parameters and obtaining multiple plots of all stack parameters.

The instrument is provided with three output ports. The RS-232 port is standard. The analog output port is also standard. The modular phone port is optional and will become operational if you have purchased the internal modem option. If you do not have this option, you can have your local distributor install it and call the factory to activate it remotely.

Please keep in mind that you can serial communications is possible with one output at a time (i.e either the RS-232 port or the modular phone jack). The ENERAC always defaults to the RS-232 when it is not communicating unless it detects an incoming call on the telephone line. In that case, the modem automatically takes control, and the RS-232 is temporarily disabled. When the telephone communication is over, or the phone line disconnected (no carrier present) , the RS-232 port will automatically be reactivated.

A. ESTABLISHING COMMUNICATIONS

The description below assumes that you have an external computer and that you wish the ENERAC to communicate with it and that the computer is equipped with a RS-232 port. It is also assumed that you have some kind of communications program installed on your computer.

NOTE: An RS-232 port is a special type of serial port. You cannot use a TTL serial port or a parallel port on your computer.

NOTE: If your computer does not have a communications program installed and if you have an IBM PC compatible computer, you can obtain such a program from any computer store. Or preferably obtain the ENERCOM™ software.

1. How to connect your computer directly to the RS-232.

The RS-232 port on the ENERAC is a female 9 pin miniature D type connector. You will need a serial cable to connect to your computer. Cable lengths can be as long as 300 ft. You can get such cables from any computer store or from Enerac, if you wish. Computers have their outputs configured for a certain type of connection known as DTE or DCE (a DTE device transmits on pin 2 and receives on pin 3, the opposite is true for a DCE).

The ENERAC can be configured either as a DTE or a DCE device. See figure 9 for the location of the serial port configuration switch.

For two instruments to communicate, they must be of opposite type (i.e. one DTE the other DCE). You must therefore, make sure your machine is a DCE. (If you are not sure, use a voltmeter to measure the voltage on pin #3

of your computer's connector. It should be negative 5v or more with respect to pin#7, ground).

To switch the ENERAC's configuration from DCE to DTE, open the hinged part of the face plate. Find the small switch that is located on the PC board near the serial communications port (to the left of the printer paper). There are labels on the pc board marked "DTE" and "DCE". Select the appropriate position. If you have trouble communicating, select the alternative position of the switch.

Some computers also need an additional signal to be present in one of the other pins, before they start communicating with each other. This is called hardware handshaking. The ENERAC does not need such a signal. If your computer needs one, the ENERAC can supply it on any pins that your computer wishes to see it.

If both the above conditions are satisfied you have met the first requirement for successful communication. (CALL ENERAC, IF YOU NEED HELP).

The second requirement for successful communication deals with establishing a common language between the two machines. There are two conditions for a common language. Speed of transmission and data format must be the same. The ENERAC model 3000E uses the following speed and data format:

SPEED: 1200 BAUD (Default)
START BITS: 1
DATA BITS: 8
STOP BITS: 1
PARITY: NONE

You must set your computer to the same values as those listed above.

The ENERAC 3000E is capable of communicating at Baud rates from 300 to 9600 baud. See the "BAUD" command in the commands section of this chapter to change the baud rate.

The ENERAC always defaults to 1200 baud every time it is turned on!

For rapid data transmission use the Enercom™ for Windows program supplied with the ENERAC and set the baud rate to 9600 baud. Your computer screen will refresh every second.

The ENERAC model 3000E will communicate via its serial port with a computer provided it has been turned on and gone through the AUTOZERO procedure WITHOUT BEING HALTED by an "... AUTOZERO ERROR" message. If such an error message appears on the display and you still wish to establish communication, by pass it by pressing the "ENTER" key!

2. How the ENERAC establishes a telephone connection.

If your ENERAC is equipped with an internal modem, use the following procedure to establish a successful telephone communication link with a remote computer:

You need to have available a direct phone line. If your telephone is connected to a special communications system, such as MERLIN™, you will need to purchase from your phone company a special device called a modem adaptor in order to communicate with the ENERAC.

1. Disconnect the telephone from wall socket.
2. Use any modular phone cable to establish a connection between the wall telephone socket and the ENERAC's RJ-11 phone connector.
3. Turn the ENERAC on and by pass all messages until the following message appears on the display:

**INSERT PROBE IN STACK
ATEMP: XXF OXY: XX.X%**

If you wish to communicate with an ENERAC operating in the field, make sure the instrument is connected to a suitable phone line. Dial the ENERAC's phone number using your computer's communication program. The instrument is always in the "autoanswer" mode. This means that it will automatically answer any remote computer that dials the telephone number

to which the ENERAC is connected. The operator's presence near the ENERAC is not required.

If there is no incoming call, or if the call is disconnected, the ENERAC's RS-232 port will be enabled and can be used with any nearby computer, even if the ENERAC is connected to the phone line. If, however, a call comes in, the ENERAC will suspend its communication via the RS-232 port and establish automatically communication with the calling computer.

You can still operate the ENERAC's buttons including the "TEXT" button in order to read stack parameters, while simultaneously maintaining a telephone connection with a remote computer.

As long as you are maintaining a telephone connection, the following message will appear every 30 seconds on the display:

"MODEM ON LINE"

to remind you that you are still connected to the phone line.

B. THE ENERAC'S LANGUAGE

Once communication has been established, you can now proceed with data transfers and the execution of commands. There are two ways to exchange information between the ENERAC and an external computer or terminal. The first method is a simple one way data dump from the ENERAC. The second, is an information exchange between the ENERAC and the computer.

1. Dumping data to a remote computer.

In this mode you just send data from the ENERAC to a connected computer by simply pushing the appropriate buttons.

To send a record of all the stack parameters currently being monitored by the ENERAC, while the probe is in the combustion source's stack proceed as follows:

1. Make sure the "SET" LED is off.
2. Establish a successful connection with the computer either via the RS-232 or the telephone.
3. Press the "SEND" key and make sure the "SEND LED" has turned on.
4. Push the "TEXT" button. A complete record of all current stack measurements is sent to the computer. The record will appear on the computer's display exactly as is shown on page 70 in chapter 7.

Note: The "SEND" key toggles the "SEND LED" on and off and also directs the output to either the serial port or the ENERAC printer, when the "TEXT" key is pressed.

To send a record of the measurements that have been previously stored in the ENERAC proceed as follows":

1. Carry out steps 1, 2, and 3 above.
4. Push next the "SET" button, "SET" LED must be on.
5. Push the "TEXT" button, the following message will appear:

```
TEST# 1      FUNC= STORE
Up/Down-Change Enter-OK
```

6. If you wish to send all the data stored, push the "ENTER" button to shift the blinking cursor to the FUNC area.
7. Use the "UP" button until the following message appears:

```
TEST# 1      FUNC=DUMP ALL
Up/Down-Change Enter-OK
```

8. Push the "ENTER" button. All measurements stored in the ENERAC's memory are sent out in sequence.

Use the "DUMP" function, if you wish to transmit only one set of data (corresponding to the TEST#).

2. Two way communication.

The ENERAC is also capable of responding to requests for data and to commands sent by the remote computer. For this purpose, it has a vocabulary of COMMANDS that the computer can send and to which the ENERAC will respond. There are two types of commands: Those designed for general use and those reserved for technical purposes in order to determine from remote locations the performance of the instrument.

All commands consist of four letter words (these are usually abbreviations of the complete word). If the command is followed by a question mark, it means that it is a request for information (i.e. it will cause the ENERAC to respond to the command by sending to its output port the specific information requested). If a command is followed by a quotation mark it will cause the ENERAC to store the data between quotes in its memory. This is the way to reprogram the instrument from a remote location. This feature makes possible the introduction of new fuels, if desired, or remote control of parameters or even the introduction of additional features and improvements without having to ship the instrument to the factory or dismantling it.

A list of the available commands intended for general use follows:

THE COMMAND SET

COMMAND	FUNCTION
ATEM?	Sends to the external computer the ambient temperature of the instrument.
BAUD X	Changes the ENERAC's baud rate as follows: X= 1 9600 Baud X= 2 4800 Baud X= 3 2400 Baud X= 4 1200 Baud X= 5 600 Baud X= 6 300 Baud When the ENERAC is turned on the baud rate always defaults to 1200 baud.
CASH?	ENERAC returns the present value of combustibles in ash stored in its memory.
CDOX?	ENERAC returns present value of carbon dioxide.
CMNX?	ENERAC returns present value of carbon monoxide.
COAM?	ENERAC returns present set value of the carbon monoxide alarm.
COMB?	ENERAC returns present value of combustibles.
DATE?	ENERAC returns present date.
DATE mm/dd/yy	Stores in ENERAC new date.
DUMP?	ENERAC returns results of all tests stored in its memory.

COMMAND**FUNCTION**

EFFI?	ENERAC returns present value of combustion efficiency.
EXAR?	ENERAC returns present value of excess air.
FL01?	ENERAC returns the fuel currently stored in location 01
.....
.....
FL15?	ENERAC returns the fuel currently stored in location 15
FUEL?	ENERAC returns the current fuel used.
LOGO?	ENERAC returns current LOGO (default value "ENERAC 3000E").
MODE?	ENERAC returns the current Emissions mode (units) and the oxygen correction factor.
MODE X	(Emissions option). Causes ENERAC to switch units of emissions gas measurements (CO, NO, NO ₂ , NOX, SO ₂) as follows: X=P PPM (Volumetric) X=M MGM (milligrams/cub.meter) X=# #/B (Lbs./million BTU) X=G GBH (Grams/brake hp-hour) X=H #/H (lbs./hour -toxics; T/D (tons/day-CO ₂))
NOXY?	ENERAC returns present value of nitric oxide (NO).
NO2Y?	ENERAC returns present value of nitrogen dioxide (NO ₂).
NOXX?	ENERAC returns present value of NOX=(NO+NO ₂)
OPTI?	Returns ENERAC's current option setting.

COMMAND**FUNCTION**

OXRf XX	(Emissions option). Causes ENERAC to set the oxygen correction factor to any number as follows: XX=0-20 (%) (In 1% steps) XX=TRUE (No correction for oxygen)
OXYG?	ENERAC returns the present value of oxygen.
PRHT?	ENERAC returns the present value of the combustion air temperature.
PRNT X..XX	Sends to the ENERAC printer the message "X..XX" up to 40 characters long. To send more characters repeat the command.
PUMP?	ENERAC returns pump status, ON or OFF.
PUMP0	Turns the ENERAC main pump off. (The probe air flow pump stays on!)
PUMP1	Turns the ENERAC main pump on. The instrument begins to draw a sample.
SETF01	Changes the ENERAC's current fuel to fuel #1. (Factory default is #2 oil).
.....
.....
SETF15	Changes the ENERAC's current fuel to fuel #15. (Factory default is SEWER GAS).
SO2X?	ENERAC returns present value of sulfur dioxide.
SRCE? XX	ENERAC returns the 10 character source id stored in location Numbered XX.

COMMAND

FUNCTION

SRCE YY XX..X	ENERAC stores in one of its 50 storage locations the emission source's 10 character alphanumeric identification as follows: YY = the storage location number (1 through 50) XX....XX = the 10 character source id.
STEM?	ENERAC returns present value of the stack temperature
TEXT?	ENERAC returns a complete record of all current stack parameters.
TEXT	Commands the ENERAC to print on its printer all the current stack parameters including time, date, fuel and "mode".
TIME?	ENERAC returns the current time.
TIME hh:mm:ss	Stores in ENERAC new time.
WARN?	ENERAC will return any warning messages currently activated.

A remote computer executing the commands TEXT? and WARN? in a continuous loop will perform as a remote continuous readout device of a source's performance.

The commands "PUMP0" and "PUMP1" allow the ENERAC to be left unattended at the combustion source site for long periods by remotely turning the main pump off and on, periodically, as needed. However, keep in mind that the probe pump air flow pump will be running continuously and its life is rated at 3000 hours.

You can type more than one commands at a time to a maximum number of commands that will not exceed 40 characters (including spaces). To send more than one command, separate each command by SPACE-SEMICOLON- SPACE.

We strongly recommend using the ENERCOMTM for WINDOWS software package to take advantage of the ENERAC's communications capability.

C. ENERAC SOFTWARE

You can use any communications program such as PROCOMM™ or WINDOWS™ TERMINAL to communicate with the ENERAC. You can, however, enhance considerably the performance of the ENERAC, by using the special ENERCOM™ FOR WINDOWS software that is supplied with every model 3000E analyzer. These software allows you to:

1. Monitor all emissions parameters simultaneously.
2. Record maximum, minimum, average and standard deviation for all emissions parameters.
3. Set alarms for every emissions parameter including recording the time duration that alarms have been exceeded.
4. Plot bar graphs and time plots of all parameters.
5. Select a variety of saving and printing options.

Consult the manual for ENERCOM™ FOR WINDOWS for details on the available software.

D. ANALOG OUTPUTS

The ENERAC 3000E uses digital to analog conversion technology to supply 0-5 volt analog voltages of its key measurement parameters to its analog output, which is located on the face plate of the instrument below the serial port.

The analog connector is also miniature 9 pin D type male connector as shown below:

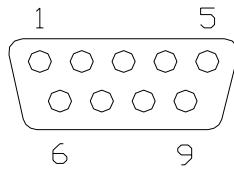

ANALOG CONNECTOR
FIGURE 13

The pin assignment and 5 volt range are as follows:

SCALE SETTINGS

PIN #	MEASUREMENT PARAMETER	HIGH RANGE	MID RANGE	LOW RANGE
PIN 1	Oxygen (%)	25.0	12.5	6.25
PIN 2	Stack temperature (F or C)	2000	500	200
PIN 3	NO₂ (PPM, MGM) Emissions (#/B, GBH, #/H)	10000 100.00	2000 10.00	500 1.00
PIN 4	Combustibles (%)	2.5	1.25	0.625
PIN 5	SO₂ (PPM, MGM) Emissions (#/B, GBH, #/H)	10000 100.00	2000 10.00	
PIN 6	CO (PPM, MGM) Emissions (#/B, GBH, #/H)	10000 100.00	2000 10.00	500 1.00
PIN 7	Ambient temperature (F or C)	200	100	50
PIN 8	NO (PPM, MGM) Emissions (#/B, GBH, #/H)	10000 100.00	2000 10.00	500 1.00
PIN 9	GROUND			

TABLE 3

If the display is reading zero for a certain parameter, then the analog output voltage for this parameter will be zero volts.

If the display over ranges for a certain parameter and displays “OVER”, then the analog output for this parameter will be 5.0 volts.

You select only one range for all analog voltages. You select the desired range by pressing the “SET” and “PLOT” keys in sequence, see chapter 6, section L.

For example, if you have selected the MID RANGE scale, then 5 volts on pin 1 will correspond to 12.5% oxygen, 5 volts on pin 2 will correspond to 500 degrees (F or C) stack temperature, 5 volts on pin 6 will correspond to 2000 PPM carbon monoxide, or 10.00 #/B (lbs/ MBTU), depending on the units the toxic sensors are set for.

NOTE: 4-20 ma outputs on all eight parameters are available on request!

CHAPTER 10

THE ENERAC'S COMPUTATIONS

A. SIMPLIFIED DESCRIPTION

The heart of the ENERAC model 3000E is an INTEL 16 bit single chip micro controller . (A micro controller is a special purpose microprocessor). This is one of the most advanced 16 bit micro controller available. A second 8 bit micro controller takes care of the printer requirements and releases the main processor from these tasks. The unit's clock speed is a very fast 12 Mhz.

The ENERAC model 3000E that includes the velocity option contains an additional micro controller in the probe circuit and communication between probe and analyzer is by serial transmission.

The system can accommodate 64K bytes of memory in the main processor and an additional 64K in the probe processor. The instrument uses a total of 40K bytes (or the equivalent of 15 full type written pages) for its code. Of these, 8K bytes are stored inside the micro controller and 32K bytes in permanent memory (2 16kx8 EEPROMS). The instrument also uses an additional 16K bytes of read or write memory (2 8kx8 battery backed SRAM). This large amount of read/write memory for a dedicated instrument is intended for enhanced remote reprogramming capability and for storage.

There is a 10 bit analog to digital conversion of the sensor outputs, that yields better than 1 part in 1000 resolution. The resolution is increased further by a running average implementation. Analog to digital conversion also takes place in the probe for units with the velocity (S-V) option.

There are three printed circuit boards (there may be a fourth one, if the internal modem is present). The main board is a high density six layer board. The power supply board is housed inside the separate power supply module to minimize noise. The third board is located inside the probe housing.

The basic ENERAC has all the connectors present so that any option can be installed, without having to ship the instrument to the factory.

B. SENSOR COMPUTATIONS

To achieve increased accuracy the thermocouple and the oxygen sensor outputs are linearized by computations in software. The emission sensors with the exception of the nitric oxide sensor (NO) do not require linearization. The nitric oxide sensor exhibits a small non linearity which is mathematically compensated during calibration.

Temperature compensation is programmed into the ENERAC for all emission sensors.

In addition a temperature control circuit is built in to the nitric oxide sensor to make sure that its temperature never exceeds 25 degrees Celsius. This is necessary to eliminate unpredictable base line drift errors caused by an increase in the ambient temperature, as required by EPA's method CTM-22.

Even though inboard filters remove most of the interfering gases, matrix computations remove any residual cross sensitivities.

Running average computations of the sensor outputs increase the resolution by a factor of five.

C. HOW EFFICIENCY IS COMPUTED

The ENERAC has stored in its memory a complete library of mathematical functions that it uses to carry out all the needed computations. It uses these functions not only to linearize thermocouple, oxygen sensor and combustibles sensor outputs but also to compute combustion efficiency, carbon dioxide, NOX and excess air.

The ENERAC uses a unique (and the most complete) formula to compute combustion efficiency. It is valid for stack temperatures above and below vapor condensation. It is based essentially on measuring all the heat loss mechanisms. Most of the heat is lost up the stack. In the case of coal fuels some potential heat is also lost by the amount of combustibles found in the ash residue.

In engine applications, the engine's thermal efficiency is not the ENERAC's combustion efficiency!

The total heat lost up the stack is made up of the following three loss components:

1. Heat carried away by the (dry) stack gases nitrogen, carbon dioxide and oxygen.
2. Heat lost by the water vapor that is formed during combustion. The heat lost by the water vapor consists of the following two terms:
 - a. Heat lost in converting the water formed by the combustion process into steam at the boiling temperature of water. (This loss is recovered in high efficiency boilers).
 - b. Additional heat lost in heating the steam formed to the temperature of the stack gases.
3. Available heat lost by any combustible (i.e. unburned) gases escaping through the stack.

The ENERAC measures all three heat losses. In addition, if the fuel is coal, it will also allow you to enter the % combustibles in the ash residue to obtain a more accurate value for the combustion efficiency (since combustible residue is also a loss component).

For high efficiency boilers (i.e. boilers operating with stack temperatures below water vapor condensation), the ENERAC will account for the reduced heat loss (i.e. increase in combustion efficiency), arising from partial condensation of the water vapor and compute the combustion efficiency correctly. (This computation is carried out under the assumption of 50% RH for the combustion air).

NOTE: It should be obvious that the ENERAC does not account for any radiation (or cooling) and friction losses that may occur at the combustion source. These losses are very small for boilers, but are typically quite high for engines. Consequently, you cannot use the ENERAC to compute the efficiency of an engine.

D. EXCESS AIR, CO₂ & AIR/FUEL RATIO COMPUTATION

Carbon dioxide and excess air are calculated by the ENERAC and are functions of the oxygen concentration and type of fuel used. *There is no carbon dioxide sensor in the unit.* Consequently, carbon dioxide values are only valid for combustion systems, that use air as the source of oxygen and do not inject carbon dioxide or oxygen in the stack. Both carbon dioxide and excess air are computed as functions of the fuel used and of the oxygen level in the stack.

Keep in mind that excess air is zero and carbon dioxide is maximum, when operating at stoichiometric conditions.

The direct computation of the air to fuel ratio (on weight basis) is available on some ENERACS. This is a very useful parameter in engine measurements. For gaseous fuels the air to fuel ratio (volume basis) may be computed by multiplying the ENERAC's display by the ratio of the specific gravities of the fuel and of air.

E. EMISSIONS CALCULATIONS

The emissions sensors (i.e. carbon monoxide, nitric oxide, nitrogen dioxide & sulfur dioxide) measure concentrations in PPM (parts per million) on a volume to volume basis. This is the default system of units for the ENERAC.

Recently, various regulatory agencies have enacted legislation requiring the measurement of emissions in units other than PPM.

The ENERAC is capable of computing directly and displaying the concentration of emissions in the following different units:

1. Milligrams per cubic meter (abbreviated as MGM). This is a popular system for ambient air monitoring.
2. Pounds per million BTU (abbreviated as #/B). The code of U.S. Federal Regulations (40CFR60 and 40CFR72) require the measurement of NOX emissions in these units.

Calculations in terms of lbs. / million BTU require the determination of certain factors called the F factors. The ENERAC uses the same values for the -F- factors as those listed in 40CFR60 Appendix A Method 19.

The EPA regulations specify the values of the -F- factors required in the computations, only for certain fuels. The ENERAC has stored in its memory the -F- factors for all fuels currently stored. For custom fuels a special -F- factor is derived and used corresponding to that particular fuel.

3. Grams per brake horsepower-hour. (Abbreviated as GBH). This system of units is used in stationary engine measurements. The ENERAC computes first emissions in grams per INPUT horsepower-hour. To convert to grams per BRAKE horsepower-hour the ENERAC divides the previous computation by the engine's thermal efficiency (*this is not the combustion efficiency of the ENERAC!!*) and displays the result. An engine's thermal efficiency is typically 25-35% (i.e. 0.25-0.35) and is usually given in the engine's manual for various load conditions. The ENERAC has a default value for the thermal efficiency of 0.3. You set the value, when you change emission units to GBH. (See Chapter 5).
4. Nanograms per joule. This system of units is used overseas. It is available on some ENERACS. The conversion factor is the following:

$$1\text{lb/million BTU} = 430 \text{ nanograms/joule}$$

5. *NOTE: New EPA regulations call for emissions measurements in units of pounds per hour. Measurements in these units require, in addition, knowledge of either stack flow velocity or fuel flow rate.*

If the ENERAC is equipped with the stack-velocity option, you can measure emissions in units of lbs/hour (for CO, NO, NO₂ & SO₂) and in tons/day for CO₂.

Some regulations also specify that toxic gas concentrations be referenced to certain oxygen levels, such as 0% (air free), 3% or 7%. The ENERAC can be programmed by the customer to carry out these computations automatically.

Please note that oxygen correction factors affect only the measurements in PPM and MGM. They do not enter the calculations in #/B, GBH or #/H!

All calculations including sensor linearizations are executed using floating point arithmetic, not look up tables, for greater accuracy and reduced memory overhead.

CHAPTER 11

MAINTENANCE

The ENERAC model 3000E is a sophisticated piece of analytical instrumentation designed to perform accurate emissions measurements. However, because it is a portable instrument, that finds use in all sorts of environments, it is important that care must be taken to prevent physical and environmental abuse, in order to maintain a trouble free operation.

There are four components in the ENERAC that will require occasional replacement (i.e. replacing them every few weeks depending on external conditions and instrument usage). These items are:

1. The sintered Hastelloy filter,
2. The disposable 1 micron fiber filter.
3. The desiccant material located inside the probe housing,
4. The printer paper.

There is an additional fiber filter located inside the desiccant chamber of the probe housing. Its function is to prevent silica gel particles from reaching the probe's counterflow pump. This filter should be replaced once a year.

There are two additional filters located inside the analyzer to protect the instrument's pump when the unit is operated without the probe. These filters should be replaced once a year.

You will probably have to replace the carbon monoxide disposable filter once or twice and the nitric oxide disposable filter four to five times during the life of the sensors, which is estimated to be approximately two years.

You will also probably have to replace the oxygen sensor once every two years.

All replacement items mentioned are easily accessible. They are either located

outside the instrument, or the can be reached by opening the hinged section of the face plate.

A. FILTER MAINTENANCE

1. The sintered filter.

The sintered Hastelloy filter is located at the tip of the probe. Typically it should normally be housed inside the probe deflector.

The filter's status is monitored by a pressure switch located inside the probe housing.

The filter should be cleaned periodically. You must replace or clean the filter, if the "FLOW BLOCKED" LED turns on during a measurement.

USE OF THE PROBE WITHOUT THE FILTERS WILL DAMAGE THE PERMEATION DRIER AND RESULT IN COSTLY REPAIRS.

Use a suitable screwdriver to remove the filter from the tip of the probe.

A filter can be cleaned three or four times. After that it should be replaced with a new one.

You can clean the filter in a variety of ways:

If most of the retained particulate matter is on the surface, a simple reverse flush with clean fluid, or air will normally restore its permeability.

If there are particulates entrained within its pores, ultrasonic cleaning is recommended. You may use a non reactive degreaser to backflush before ultrasonic cleaning.

During any blowback or backwash operation, intermittent pulses of gas or liquid are far more effective than a steady reverse flow.

If the contaminants are combustibles, you may try conventional oven burning followed by ultrasonic cleaning.

The filter is made of Hastelloy X and it can withstand temperatures of 1700 F continuously and 1900 F for a few minutes.

2. The disposable fiber filter.

This filter is located inside the probe gas manifold. (See figure 5). It is disposable and will have to be replaced occasionally, or if the "BLOCKED FILTER" LED turns on.

To replace the filter, remove the threaded filter holder that is located on the side of the case of the probe. You can use a small coin to unscrew the filter housing. Insert a new filter into the removed filter housing making sure that the filter is seated properly! Screw the filter assembly into the manifold taking care not to lose the Vidian washer that is located inside the manifold.

Do not use any filter other than the ones supplied by Enerac!

Use of the probe without the filters will damage the permeation drier and result in costly repairs.

B. DESICCANT REPLACEMENT

The desiccant is the blue crystalline material (silica gel) located inside the probe housing. Its condition can be monitored through the narrow rectangular window located on the face of the probe housing. As this material absorbs water vapor, its color changes to pink and finally to white-pink as it becomes saturated with water. It should be replaced with fresh desiccant when it is used up.

Use only silica gel as desiccant. Other desiccants such as drierite crumble into powder and will clog the 40 micron air filter located inside the desiccant housing.

The desiccant does not come into contact with the drawn gas sample. Its function is to dry the counterflow air that the permeation drier uses. For optimum drying performance make sure the desiccant color is blue!

To replace the desiccant, unscrew the aluminum plug that is located at the bottom of the probe housing. Carefully empty the desiccant compartment. Fill it with fresh desiccant and secure the plug to the opening.

Air enters the desiccant chamber through the three slots located on the face of the probe housing. If you plan to store the instrument, you may wish to tape over the slots to prevent the desiccant from absorbing moisture, gradually.

Used desiccant can be regenerated by placing it in 250 degree F oven for 30 minutes until it recovers its blue color.

C. PAPER REPLACEMENT

The ENERAC's printer uses a special paper called thermal paper. ALWAYS USE THE PROPER TYPE OF THERMAL PAPER. If the wrong paper is inserted, the printer may not operate at all or the printer's thermal heads may be damaged. If you notice that the printer is printing incomplete letters, this is an indication that one or more of the printer heads have been damaged. In that case you have to order a complete head assembly from the company and install it yourself.

Do not leave thermal paper exposed to heat or humidity, because it will gradually turn yellow.

When there are only 3 ft. of paper left in the roll, you will see a red line appearing on the left border. This is a warning that there is little paper left and order a new roll.

There is a paper sensor located behind the printer. The printer will operate as long as the sensor's beam is interrupted by the paper. When there is no paper, the sensor disables the printer to avoid damaging the thermal heads. Simultaneously, the following message will appear on the display every fifteen seconds:

"PRINTER PROBLEM"

To insert a new roll of paper, open the hinged side of the face plate. Lift the rod that holds the paper. Insert a new roll of paper and gently press the rod back against the supporting clamp. Take out about 3" of paper and pass it through the rear of the printer making sure that it goes between the paper sensor's openings. Use the small thumbwheel located on the right hand side of the printer to slowly push the paper through the printer. Once the paper is through you can pass it through the cutout on the face plate. Use the "PAPER FEED" switch to advance

the paper.

D. SENSOR AND SENSOR FILTER REPLACEMENT

1. Replacing the oxygen sensor

The oxygen sensor is an electrochemical cell and has a limited life. It should last approximately two years. The oxygen sensor's date code is stored in the instrument at the time of its manufacture.

If, at start up at the end of the AUTOZERO countdown, the message,

“OXY AUTOZERO ERROR”

appears on the display, it means that the sensor is no longer functioning satisfactorily and should be replaced.

Before replacing an oxygen sensor, however, open the hinged plate and take a look at the cables leading to the sensor housing. Make sure that no wires have accidentally been disconnected.

If the above ERROR message appears for the first time, try operating the unit for a few hours in a clean environment, in case the sensor got wet. If this doesn't work, you must replace the oxygen sensor.

To replace the oxygen sensor, open the hinged section of the face plate. Remove the five captive screws that secure the cover to the sensor housing. See figure 14. Pull out the housing cover. The sensor is the small battery like device attached to the cover. Unscrew the sensor wires and remove the old sensor.

Take a new sensor and attach it to the cover. Carefully screw the sensor leads observing the proper polarity. Place back the cover and tighten the six screws

so that the housing is air tight. Make sure you don't damage the gasket. Close

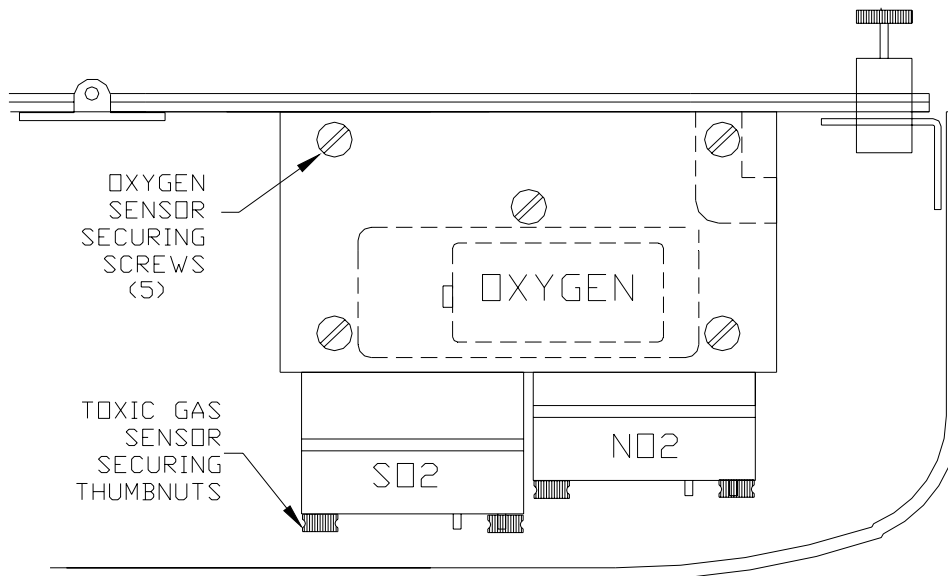

FIGURE 14

the hinged plate. Wait 10 minutes. Turn the instrument on. If everything is OK, it should warm up without the "OXY AUTOZERO ERROR" message appearing at the end of the countdown. If the ERROR message appears again, turn the unit off wait 5 minutes and turn it back on. If the error message still appears, open the hinged plate and examine the wires to the sensor. Make sure you have attached the wires with the correct polarity.

THE SEM™ EMISSIONS SENSORS DESCRIBED BELOW, ARE PROPRIETARY SENSORS DEVELOPED SPECIFICALLY FOR EMISSION MEASUREMENTS AND CONTINUOUS OPERATION.

2. Replacing the carbon monoxide sensor and filter.

The carbon monoxide and its associated long life inboard filter are mounted as one assembly on the instrument's sensor housing. The filter is located at the front of the assembly.

The carbon monoxide sensor is an electrochemical cell. Its expected life is about 2 years. During manufacture the sensor's date code is stored in the instrument. The sensor's inboard long life filter should last for a year.

Monitor the "ENERAC CALIBRATION PROTOCOL " that is printed on the instrument's printer during span calibration to determine proper sensor and filter operation.

a. CO Precision Control Module (PCM) replacement.

The function of the CO PCM is twofold. It contains an appropriate filter media to remove any interference by nitric oxide and other gases. It includes also the capillary holes that allow entry of the gas to the sensor and thus, control the sensor's sensitivity.

The PCM is located directly in front of the sensor and is mounted as one assembly. See chapter 3. The performance of the filter media is checked during span calibration.

The following two messages appearing on the ENERAC's printer, indicate approaching filter exhaustion:

REPLACE CO SENSOR FILTER SOON

OR

REPLACE CO SENSOR FILTER

To replace the filter (PCM), remove the four thumbnuts that secure the filter and sensor assembly to the housing. See figure 12. Do not disconnect the sensor from the small PC board. Remove the disposable filter and replace it with a new one.

The filter has a set of tabs that allow it to be mounted only on a carbon monoxide sensor. Align the PCM tabs with the sensor sockets.

Do not disconnect the wires from the sensor during filter change.

Autozero and span calibrate the instrument after every PCM change.

b. CO sensor replacement

When the following message appears during autozero:

"CO AUTOZERO ERROR"

or the following message appears during span calibration:

"REPLACE CO SENSOR"

it means that the CO sensor is no longer meeting the required specifications for accuracy and must be replaced with a new one.

If the "CO AUTOZERO ERROR" message appears, before replacing an apparently malfunctioning sensor, let the ENERAC run for 2 hours in a clean environment, (you will have to push the "ENTER" button to continue). Sometimes a malfunction message appears, if the sensor got wet, or if it had been saturated with carbon monoxide during a measurement. Turn the unit on again. If the error message still appears, replace the sensor.

To replace the sensor open the hinged section of the face plate. Take out the four thumbnuts that secure the sensor and its filter to the housing. The sensor is mounted on a small PC board. Disconnect the PC board and remove the sensor.

Take a new CO sensor. Handle it with care. *DO NOT TOUCH THE SENSOR ELECTRODE AREA* . Mount the sensor on the small PC board. Make sure that the O-ring is properly seated between the sensor filter and the sensor housing. Finger tighten the securing thumbnuts, so that there are no air leaks.

After replacing the co sensor, you must wait at least 24 hours for the sensor to condition itself, before executing an autozero and using the instrument!!

Turn the instrument on. Execute an autozero. If the "CO AUTOZERO ERROR" message appears, check your wiring to the sensor.

Make sure you carry out a span calibration following sensor installation.

3. Replacing the NO, NO₂ & SO₂ sensors and PCMs.

The nitric oxide (NO) and its associated long life inboard filter are mounted as one assembly on the instrument's sensor housing. The Precision Control Module is located at the front of the assembly. The filter media of the PCM removes interference from NO₂ and SO₂.

The sensor is an electrochemical cell. Its expected life is about 2 years. During manufacture the sensor's date code is stored in the instrument.

The nitric oxide sensor is mounted on a special cooling plate. Below the plate and in contact with the aluminum sensor housing there are two small thermoelectric coolers. See figure 7. The sensor has an internal temperature sensor that will turn on the thermoelectric coolers, if the sensor temperature rises above 25 degrees Celsius.

The nitrogen dioxide (NO₂) is mounted on the instrument's sensor housing. This sensor has no PCM and no filter media.

The sensor is an electrochemical cell. Its expected life is about 2 years. During manufacture the sensor's date code is stored in the instrument.

The sulfur dioxide (SO₂) and its associated long life inboard filter (PCM) are mounted as one assembly on the instrument's sensor housing. The filter is located at the front of the assembly. The filter removes interference from H₂S.

The sensor is an electrochemical cell. Its expected life is about 2 years. During manufacture the sensor's date code is stored in the instrument.

Always check the "ENERAC CALIBRATION PROTOCOL " that is printed on the instrument's printer during span calibration to determine proper sensor and filter operation.

Follow the instructions for removing the carbon monoxide sensor and its

PCM.

WHEN REPLACING THE NO AND SO₂ SENSORS YOU MUST WAIT AT LEAST 24 HOURS, BEFORE OPERATING THE INSTRUMENT, BECAUSE THESE SENSORS ARE OPERATED WITH A CERTAIN BIAS AND REQUIRE A CERTAIN AMOUNT OF TIME FOR THE SENSORS TO CONDITION THEMSELVES. WHEN REPLACING THE NO₂ SENSOR YOU NEED TO WAIT ONLY 15 MINUTES, SINCE THIS SENSOR IS NOT OPERATED WITH A BIAS VOLTAGE.

Make sure the instrument is always off when the hinged panel is opened.

CHAPTER 12

CALIBRATION

Every instrument must occasionally be calibrated against some known value of a parameter in order to make sure that its accuracy has not deteriorated.

The instrument software make sure that the display readout is always a linear function of the source excitation (i.e. gas concentration or temperature etc.). You therefore need only two points on the straight line to calibrate a parameter over its entire range. Usually, the first point chosen is the zero value (called zeroing the instrument). The second point has to be set by using some known value of the parameter being calibrated (i.e. using for example 200 PPM certified carbon monoxide gas to set the display to read 200). Sometimes the second point is not needed, if the slope of the parameter is known and is always the same (for example for the stack temperature the slope of the curve is well known and you don't need a span calibration).

Traditionally, both zeroing and span (i.e. second point) calibration was done manually, by rotating suitable potentiometers until the display was set to read first zero in ambient air and then the correct value using span gas.

With the introduction of microprocessors, it became a simple matter for instruments to zero themselves automatically upon start up (AUTOZERO) , without having to use any adjustments However, this simplification requires caution. The instrument must be started in a true "zero" environment. Otherwise it will assume as "zero" non zero conditions and give erroneous readings. (Example: Never autozero the ENERAC, if the probe tip is still hot following a recent measurement.)

The ENERAC carries out this improvement in automatic calibration procedure one step further. It does away with all potentiometric span adjustments. You just tell it the value of the calibrating parameter that you are using and the instrument adjusts itself automatically.

In addition, it carries out a systematic checkout of sensor performance and instrument integrity through a novel approach called the "ENERAC

CALIBRATION PROTOCOL". This protocol is explained below.

The ENERAC will "auto zero" itself every time you start the instrument, provided you push the ENTER key. Span calibration will be carried out on request.

You should carry out a span calibration every 3-4 months to maintain an instrument accuracy within specifications. Some regulatory requirements specify that a span calibration be carried out before each measurement. In that case you may find the Enerac portable calibration kit very useful.

A. THE ENERAC CALIBRATION PROTOCOL

To maintain the integrity and accuracy demanded of a regulatory compliance apparatus, the ENERAC 3000E has been given an extensive and comprehensive "calibration protocol", that will appear on its printer every time a calibration is carried out.

The protocol checks both instrument zero and span performance and serves to instill to the operator confidence on the integrity of his data.

1. The autozero protocol.

Every time the ENERAC is autozeroed, the performance of the sensors is checked to make sure that sensor zero baselines are within the prescribed limits. The following is a typical printout indicating no errors at the end of the autozero period:

```
AUTOZERO PROTOCOL  
TIME:02:22:47  
DATE: 05/20/96  
  
NO AUTOZERO ERRORS
```

If one or more of the sensors are outside the specified limits a message will appear on the display and printed simultaneously on the ENERAC's printer for documentation.

2. The span calibration protocol.

Since the calibration protocol checks the sensor's selectivity against interfering gases, you must always use SINGLE TOXIC GAS MIXTURES (i.e. do not use mixtures containing two of the following gases in one cylinder: carbon monoxide, nitric oxide, nitrogen dioxide and sulfur dioxide).

(The only exception to the SINGLE TOXIC GAS rule is to use a blend of NO and SO₂ gas bal. Nitrogen, in order to determine the performance of the NO sensor filter media. Cross interference of the NO sensor to SO₂ gas is detected only, if NO gas is present! Do not use, however, this blend to carry out any calibrations. Use it just to check sensor response.)

Every time the ENERAC is calibrated using span gas, a number of different parameters are checked for satisfactory performance.

The following type of a message will appear on the ENERAC printer at the end of a span calibration (the results of a typical nitric oxide span calibration are shown in the box below)

```
ENERAC MODEL 3000E
SERIAL # ABC123XX

CALIBRATION PROTOCOL

CO SPAN GAS: 640 PPM
SENSOR CALIBRATION SUCCESSFUL
CO SENSOR OK
BY: _____

TIME:02:19:96
DATE:05/20/96
```

a. Air leak check.

The instrument is checked for air leaks during span calibration.

The air leak check is carried out only when calibrating the NO sensor, since NO span gas must always have zero oxygen.

If a leak is detected the following messages appear on the printer:

"SENSOR CALIBRATION FAILED"
"DETECTED SYSTEM AIR LEAK"

If an air leak is discovered, first check the gas connection to the tip of the probe to make sure that it is air tight. Following this, determine if the leak is in the probe or in the instrument. You can do this by passing the probe and feeding the gas to the instrument directly. Contact Enerac for further assistance.

b. Sensor sensitivity check.

The output of the sensor undergoing calibration is checked against its original sensitivity that has been stored in its memory. If the sensor's sensitivity is within the acceptable limits, the following message appears on the printer:

"SENSOR CALIBRATION SUCCESSFUL"
"XX SENSOR OK"

where XX refers to the sensor being calibrated.

If the sensor's sensitivity is slightly outside acceptable limits, but the sensor is still functioning properly, the following messages appear on the printer:

"SENSOR CALIBRATION SUCCESSFUL"
"REPLACE XX SENSOR SOON OR CHECK GAS"

The purpose of the last message is to warn the operator that the sensor might soon need replacement, or that the wrong span gas value has been entered accidentally.

Be careful when calibrating the NO₂ sensor with span gas. NO₂ span gas concentration deteriorates with time. Don't use any cylinders that are more than 6 months old. Buy from a reputable supplier. Don't use any external desiccants or water traps.

If the sensor's sensitivity is considerably outside acceptable limits, the sensor is considered as not functioning properly and should be replaced. The following messages appear on the printer:

"SENSOR CALIBRATION FAILED"
"REPLACE XX SENSOR OR CHECK SPAN GAS"

c. Sensor selectivity check.

The Precision Control Modules of the CO, NO and SO₂ sensors have long life inboard filters to remove any interfering gases that may be present in the sample.

Filter life depends on the sensor, the concentration of the gas and exposure time of the interfering gas. Typically, for the ENERAC's SEM sensors it is 200,000 PPM-hours for the CO sensor and 20,000 PPM-hours for the NO sensor to NO₂ gas and 100000 PPM-hours to SO₂ gas.

If the cross sensitivity of the interfering gas rises to 2% for CO or 6% for NO the following warning message will appear on the printer:

"REPLACE XX SENSOR FILTER SOON"

If the cross sensitivity of the interfering gas rises further (i.e. 5% for the CO sensor) the following message will appear on the printer:

"REPLACE XX SENSOR FILTER"

Please keep in mind that irrespective of the inboard filter performance, the ENERAC mathematically compensates for any residual cross sensitivity, so that measurements can be taken with reasonable accuracy (but not compliance level accuracy), even if the filters need replacement.

B. AUTO ZEROING THE INSTRUMENT

Every time you turn the instrument on, you should wait for 2 minutes for the

ENERAC to warm up(OR UNTIL THE GREEN "PROBE OK LED TURNS ON). At the end of the warmup period the ENERAC reads the output of all sensors and

sets them all to zero with the exception of the oxygen that it sets to 20.9%. (The ambient temperature is read directly). Consequently, it is very important that at the moment of "zeroing" the probe tip is at room temperature and the environment is clean from traces of carbon monoxide or other gases.

NOTE: In practice AUTOZEROING is only needed once at the beginning of a day of measurements. The ENERAC will not have sufficient zero drift during the next 24 hours to require additional autozeroing procedures.

You can bypass the AUTOZERO procedure by pressing any key other than the "ENTER" key, when prompted to do so by the display.

If the instrument has not been used for quite some time, it is a good idea to give it a longer warmup period. To do this turn the unit off at the end of its initial warmup and then turn it immediately back on.

If you accidentally shut off the unit, while the probe is still in the stack, turn the unit back on and bypass the Autozeroing procedure by pressing any key other than the "Enter" key when the message "press enter to autozero" appears.

C. INSTRUMENT SPAN CALIBRATION

Ideally, you should span calibrate the instrument every time you replace a Precision Control Module. At a minimum, once every 3-4 months you should perform a span calibration of the instrument. The parameters that require a span calibration are: carbon monoxide, combustibles, nitric oxide, nitrogen dioxide and sulfur dioxide.

There is, also, a span calibration for the ambient temperature sensor.

For instruments that have the stack-velocity (S-V) option, there is an additional calibration of the very low pressure sensor and a command to adjust the Pitot tube factor.

You can carry out all span calibrations in sequence or just one only, if you wish.

You can use your own span gas, or if you need to calibrate the ENERAC in the field, you can use the convenient gas calibration kit supplied by Enerac.

Remember, that every ENERAC 3000E has a dual range CO, NO and SO₂ switch. Therefore, in order to execute a complete span gas calibration you must use the appropriate span gas with the dual range switch in the “LOW RANGE” position and also in the “HIGH RANGE” position.

1. Span calibration using the Enerac kit.

The gas calibration system supplied by Enerac is shown in Figure 15. The kit comes with a gas cylinder containing a mixture of 200 PPM carbon monoxide (typically), 1.0% methane and balance nitrogen. For NO, NO₂ and SO₂ calibrations you must order extra gas cylinders containing the desired type of span gas. All four gas cylinders and apparatus fit inside a carrying case for easy transportation to the field.

If you are going to use only the four gas cylinders that fit in the Enerac calibration kit, make sure that the concentration of the span gas that you order can be used to calibrate both the low range and high range sensor spans.

The following approximate concentrations are recommended for the Enerac calibration kit, assuming you will be using the **“MID” PCM modules**:

Carbon monoxide/methane: 1500 PPM CO, 1% methane, balance nitrogen.

(If you have the hydrocarbons option then use 1500 PPM CO, 0.5% propane , balance nitrogen).

Nitric oxide: 900 PPM nitric oxide, balance nitrogen.

Sulfur dioxide: 1500 PPM SO₂, balance nitrogen.

Nitrogen dioxide: Any value 50-400 PPM NO₂, balance air, preferably.

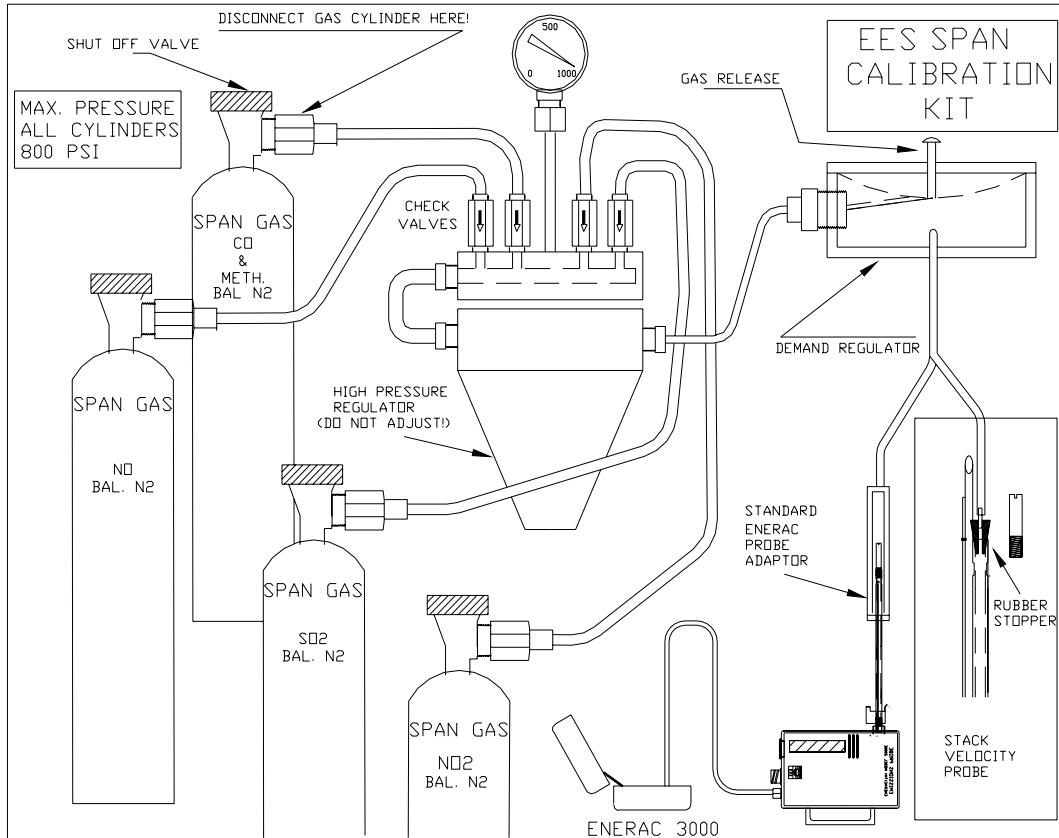

FIGURE 15

NOTE: For EPA approved measurements, please see the following section. The nitric oxide “LOW” PCM module requires a span gas of less than 300 PPM).

Begin your calibration procedure by following the instructions in the first part of the calibration kit up to the chapter on calibration the ENERAC 2000E-3000. After that, follow the instructions on “span calibration using your own gas”, that are outline below. Do not forget to calibrate both the “LOW RANGE” and the “HIGH RANGE” sensitivities by toggling the dual range switch and repeating the span calibration for the same sensor!

NOTE: If you are using the stack-velocity probe, remove the sintered filter from the tip of the probe and insert the rubber stopper, that is located at the end of the calibration kit hose assembly into the ENERAC probe’s sample extraction tube.

For the span calibration of the AMBIENT TEMPERATURE follow the directions in section 2 below.

2. Span calibration using your own gas.

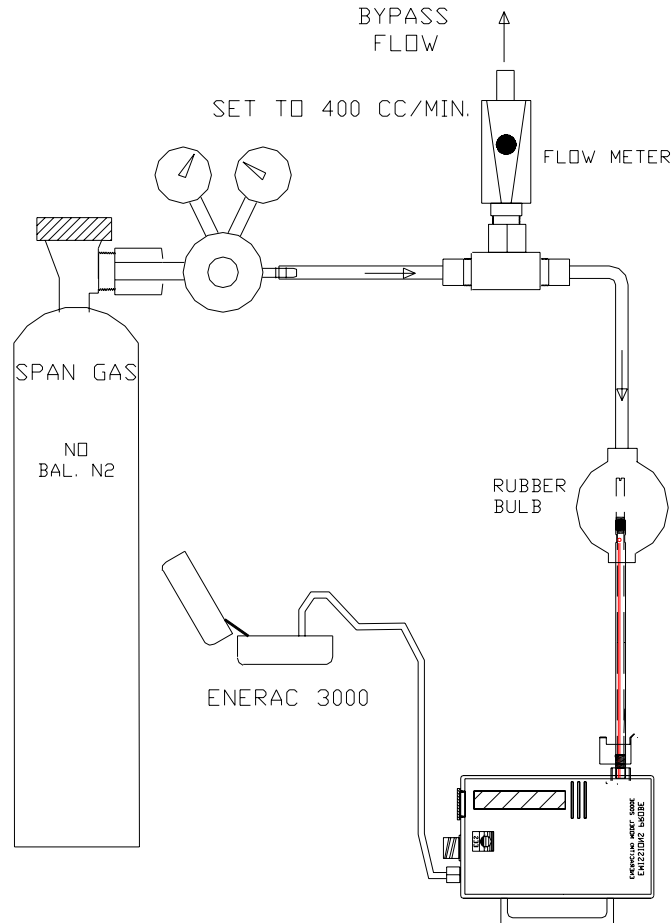

(Use single toxic gas mixture!)

FIGURE 16

If you wish to use your own gas to perform span calibrations you must take certain precautions, in order to calibrate the sensors properly.

Preferably, for greatest accuracy it is recommended that you use a span gas value close to the emission concentration you expect to measure.

To carry out a span calibration USING YOUR OWN GAS APPARATUS follow the steps below:

1. Set up your calibration apparatus as shown in fig. 16.

NOTE: If you are using the stack-velocity probe (S type pitot tube), take a small perforated rubber stopper and insert a hose barb fitting to its wide end. Connect the hose of the calibration apparatus to the hose barb fitting. Remove the sintered filter from the tip of the probe. Insert the narrow end of the rubber stopper to the tip of the probe making sure that you establish a good seal! (You can obtain this accessory from the factory).

Notice that you need a number of certified gas cylinders. Make sure you use the calibration accessory supplied with your instrument. The accessory ensures proper gas flow to the ENERAC.

You must not feed gas to the ENERAC under pressure and you must not starve the ENERAC's pump for gas. When feeding the gas to the ENERAC you must maintain the pressure reasonably constant. This is a requirement of all diffusion type sensors.

Connect the calibration accessory to the ENERAC probe. Make sure the rubber bulb is inserted past the square grooves located at the probe tip.

Connect the other end of the calibration accessory to the gas cylinder.

Make sure the concentration of the calibration gas is within the range of the Precision Control Module selected for each sensor. Do not under any circumstances, use gas that will over range the PCM. Preferably, do not calibrate with gas whose concentration is lower than the PCM's range's lower boundary.

The Carbon Monoxide gas can be in the range 30-20000 PPM 2% accuracy with the balance nitrogen, preferably.

The Combustible gas can be in the range 0.07%-3.0% methane, 2% accuracy with the balance nitrogen or air. (For the hydrocarbons option it should be in the range 0.1 – 0.5% propane).

The NO span gas can be in the range 10-3500 PPM, 2% accuracy with balance nitrogen.

The NO₂ span gas should be in the range 50-500 PPM, 2% accuracy balance air, preferably.

The sulfur dioxide span gas can be in the range of 30-7000 PPM, 2% accuracy, balance nitrogen, preferably.

If you plan to calibrate all sensors, follow the order of their appearance on the display. This is desirable in order to set the compensating matrix for cross sensitivities, properly. Make sure you span calibrate each of the CO, NO, and SO₂ sensors for both low and high ranges by toggling the respective dual range switch and repeating the span calibration for the same sensor.

2. Turn the instrument on, press ENTER to autozero and wait until the following message appears on the display:

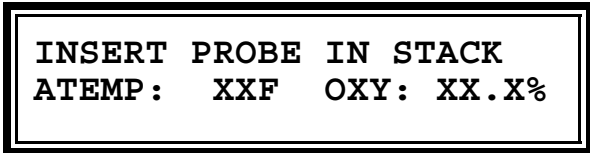

**INSERT PROBE IN STACK
ATEMP: XXF OXY: XX.X%**

3. Push the "SET" button and observe "SET" LED turn on.
4. Push the "NO/NO₂" button. The following message will appear:

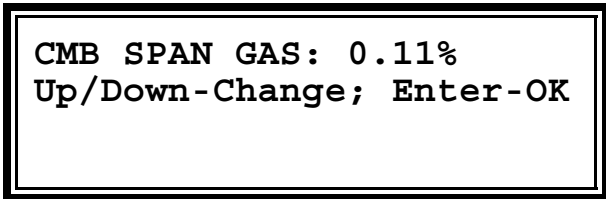

**CMB SPAN GAS: 0.11%
Up/Down-Change; Enter-OK**

Step #5 below demonstrates how to by pass an unwanted span calibration and proceed to the next one.

5. (If you wish to skip the Combustibles calibration push the "ENTER" button. The display will read:

**PRESS ENTER KEY !!
Up/Down-Change; Enter-OK**

Press any button, except the "ENTER" button and the unit will skip the combustibles calibration and proceed to the next one.)

6. To carry out the combustibles span calibration, use the "UP" or "DOWN" buttons until the display reads the same combustibles value as that printed on the combustibles (methane) gas cylinder label. Open the span gas valve and set your gas bypass flow (as indicated by the small flow meter of the calibration accessory) to 200-400 cc/min. Make sure the flow rate indicated is reasonably constant, then press the "ENTER" button. The following message will appear on the display:

FEED GAS AND WAIT!

7. Make sure you keep the gas flow reasonably constant by monitoring the flow meter. At the end of approximately four minutes the ENERAC will record and store the combustibles sensor response and define it as the value that you set earlier on the display.

When the following message appears on the display:

CALIBRATION SUCCESSFUL

it means that you are finished with the combustibles span calibration and the instrument is prompting you to perform the CO calibration next. Shut off the gas!

Note: If the message "CALIBRATION FAILED" appears, it is an indication that

there is something wrong with the sensor and the ENERAC will keep in its memory the previously stored sensitivity factor for combustibles.

At this time you must press any key to continue!

As soon as you press any key the following message will appear on the display indicating the PCM currently mounted on the sensor and prompting you to carry out the CO span calibration:

<p>SNS CO: PCM: 2K PPM(M) Up/Down-Change; Enter-OK</p>
--

8. To carry out the CO (carbon monoxide) span calibration follow the procedure outlined above for the combustibles calibration.

A number of important messages, that are part of the "ENERAC CALIBRATION PROTOCOL", will appear on the printer at the end of the CO calibration.

If you wish to skip the CO sensor calibration proceed as in step 5. The following message will appear on the display:

<p>SNS NO: PCM: 1K PPM(M) Up/Down-Change; Enter-OK</p>
--

prompting you to carry out this calibration.

Please note that according to "ENERAC Calibration Protocol" this calibration also checks the performance of the CO sensor interference (from NO gas) rejection filter.

You may carry out or by pass this calibration, as you wish.

9. The next sensor calibration in line is sulfur dioxide and the following message will appear on the display;

SNS SO₂: PCM: 2K PPM(M)
Up/Down-Change; Enter-OK

If you wish to carry out any of these calibrations, proceed as outlined in steps 5, 6, and 7.

*IMPORTANT NOTE: SO₂ AND NO₂ gases are "sticky" gases. That means that they tend to adsorb partially to the surface of materials causing a slow down of the response time of the instrument. For this reason, it is a good practice when calibrating with SO₂ or NO₂ span gases, to begin feeding the gas at **least four minutes before executing the span calibration!***

10. The last sensor calibration to be carried out is nitrogen dioxide and the following message will appear on the display:

SNS NO₂: 100 PPM
Up/Down-Change; Enter-OK

prompting you to carry out this calibration in turn.

Please note that this span calibration also checks the performance of the NO sensor (interference rejection) inboard filter and in addition, the performance of the SO₂ sensor according to the "ENERAC Calibration Protocol".

3. Optional velocity span calibration!

The next message on the display in the calibration procedure involves the span calibration of the velocity sensor. You carry out this calibration only if you have the stack velocity option (S type pitot tube probe) and suspect that the velocity sensor is out of specs.

The following message will appear on the display:

VELO.PRESSURE: 1.00IN WC
Up/Down-Change; Enter-OK

To carry out the velocity pressure calibration (i.e. stagnation pressure minus static pressure measured in inches WC), you will require an accurate inclined manometer, or some other very low pressure calibrator. A typical connection using the inclined manometer is shown in figure 17.

If an inclined manometer is used, keep in mind that its resolution is inferior to the ENERAC's sensor!

Assuming the ENERAC has been properly autozeroed you proceed as follows:

1. Open the needle valve and allow the manometer to reach its zero equilibrium. Check that the display reads zero FPS (feet/second).
2. Enter the span calibration mode, by pass the sensor calibrations until the "VELO.PRESSURE:2.00 IN WC" appears on the display.
3. Squeeze the rubber bulb **SLIGHTLY & SLOWLY** to register a reading on the manometer between 0.5 and 2.00 inches WC.

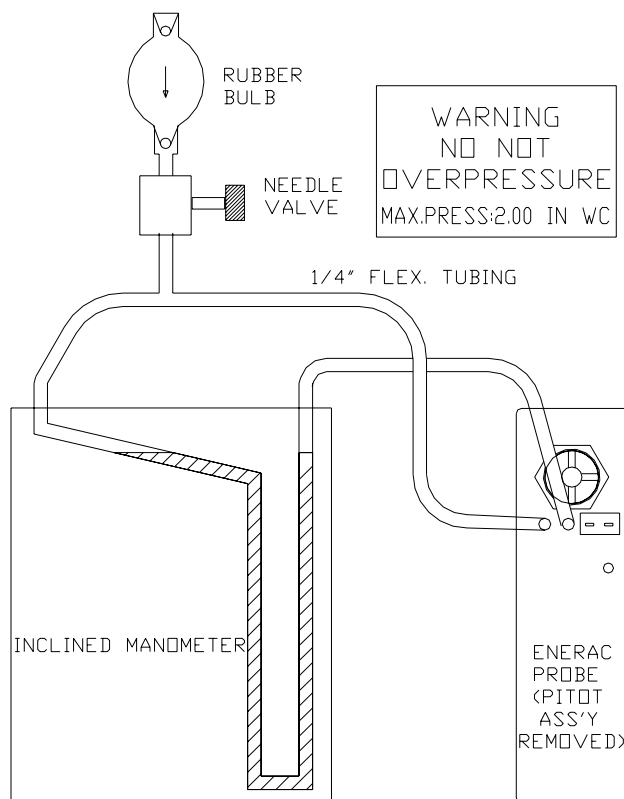

FIGURE 17

NOTE: If you are using a fluid other than water in your manometer, make sure you multiply the reading by the fluid's density to convert the manometer deflection to inches of water column!

4. As soon as you get a good reading on the manometer, close the needle valve to make sure the reading remains stable. (The rubber bulb's check valves are not leak proof).
5. Use the ENERAC's "UP" or "DOWN" keys to set the display's reading equal to the reading of the manometer.
6. Press the "ENTER" key to execute the velocity calibration.

NOTE: According to the EPA's 40CFR60, Method 2 requirements, you need not calibrate the S type pitot tube itself, provided the pitot tube3 design meets the criteria outlined in Method 2. The ENERAC 3000E meets these criteria and assumes a pitot factor of 0.8.

4. Ambient temperature calibration.

The next parameter that will appear on the display following the velocity calibration is a prompt to correct any inaccuracy in the ambient temperature indication of the ENERAC's display.

The following message appears on the display following the velocity calibration:



ATEMP OFFSET: - 0 C
Up/Down-Change; Enter-OK

This calibration corrects for any inaccuracy in the ambient temperature reading. It allows you to make minor corrections so that the ENERAC will read the exact ambient temperature.

You can only enter the correction in degrees Celsius. Use a good thermometer to compare with the ENERAC's ambient temperature reading and correct accordingly.

5. Oxygen offset (air) adjustment.

The last parameter that can be adjusted is the value of the oxygen concentration of ambient air as seen by the analyzer's oxygen sensor. Please refer to Appendix D for details.

The following message will appear following the ambient temperature calibration message:

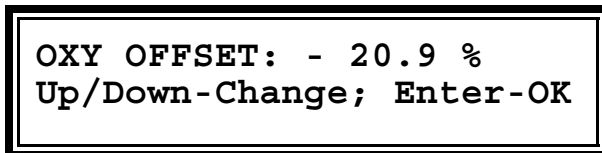

OXY OFFSET: - 20.9 %
Up/Down-Change; Enter-OK

You can adjust the oxygen range from 20.1% to 20.9% . This adjustment will affect the emission source's oxygen and mass emissions readings, so be careful and cautious in making any changes!

At the end of the span calibration procedure the analyzer exits the calibration mode and resumes its normal measurement mode.

NOTE: If you wish to exit the span calibration procedure at any time, other than when the message "FEED GAS AND WAIT" is displayed simply press the "SET" key and observe the "SET LED" turn off.

Whenever the message "FEED GAS NOW AND WAIT" appears, the ENERAC is inside a software loop and will not respond to any keys or communicate with external computers. SHUT THE INSTRUMENT OFF, IF YOU HAVE TO ABORT A SPAN CALIBRATION.

INCREASED ACCURACY REQUIREMENTS

- ALLOW THE INSTRUMENT TO REACH AMBIENT TEMPERATURE BEFORE CARRYING OUT A SPAN CALIBRATION OR MEASUREMENT.
- FOR NO, NO₂ AND SO₂ CALIBRATIONS, FEED THE SPAN GAS FOR A MINIMUM OF 10 MINUTES BEFORE EXECUTING THE SPAN CALIBRATION PROCEDURE.
- DURING A MEASUREMENT MAINTAIN THE SAME FLOW RATE INTO THE INSTRUMENT (+/- 10%) AS DURING SPAN CALIBRATION BY ADJUSTING THE SAMPLE PUMP VOLTAGE, IF NECESSARY.
- TO ACHIEVE THE BEST MATHEMATICAL COMPENSATION, USE NO₂ SPAN GAS TO CALIBRATE, WHOSE CONCENTRATION IS APPROXIMATELY THE AVERAGE CONCENTRATION OF YOUR EXPECTED EMISSION.
- CHECK THE NO FILTER INTERFERENCE REJECTION OF SO₂ GAS BY FEEDING A BLEND OF KNOWN CONCENTRATIONS OF NO AND SO₂ GASES.

CHAPTER 13

EPA REFERENCE METHOD MEASUREMENTS

This chapter describes the procedures to follow when using the ENERAC model 3000E for measurements according to the EPA reference method protocol.

Following the EPA protocol requires additional setup time, but results in accurate and defensible data.

A. NOX EMISSION MEASUREMENTS

The ENERAC model 3000E meets all the requirements and specifications of the U.S. Environmental Protection Agency's conditional reference method (**EMTIC CTM-022.WPF**) entitled "**DETERMINATION OF NITRIC OXIDE, NITROGEN DIOXIDE AND NOX EMISSIONS FROM STATIONARY SOURCES (ELECTROCHEMICAL ANALYZER PROCEDURE)**". According to the Reference protocol you can use the ENERAC to measure "...nitrogen oxides (NO and NO₂) concentrations in controlled and uncontrolled emissions from combustion sources, such as boilers, heaters, engines and turbines. This method should not be applied to other pollutants or emission sources without a complete investigation of analytical interferences and a comparative evaluation with other EPA methods."

1. Range selection

Before taking any measurements you must select the proper NO range as specified by the Reference Method: "...for this method, a portion of the analytical range is selected by choosing an appropriate sensor sensitivity range. The sensor's sensitivity range must be selected so that the emission standard falls within the sensor's range. A sensor's sensitivity range is limited by performance specifications for lower and upper concentration boundaries."

The ENERAC NO sensor is supplied with three PCM's as listed in Table 1. The NO₂ sensor has a standard range 0-500 PPM.

Select the appropriate range and install the appropriate NO Precision Control Module as outlined in Chapter 2 and shown in Figure 1A.

2. Initial use testing procedure

This procedure requires the following calibration span gases:

SENSOR-PCM	CALIBRATION GAS		
	ZERO GAS	40%-60%	80-100%
NO-LOW RANGE	PURIFIED AIR	120-180 PPM (#1)	240-300 PPM (#2)
NO-MID RANGE	PURIFIED AIR	400-600 PPM (#3)	800-1000 PPM (#4)
NO-HIGH RANGE	PURIFIED AIR	1400-2100 PPM (#5)	2800-3500 PPM (#6)
NO ₂	PURIFIED AIR	200-300 PPM (#7)	400-500 PPM (#8)
NO MID RANGE & NO ₂	CO 500 PPM +/- 10%		
NO MID RANGE & NO ₂	SO ₂ 200 PPM +/- 10%		
NO MID RANGE & NO ₂	CO ₂ 10% +/- 10%		

3. No sensor tests drift, calibration error, sampling sys. bias

1. Prepare the purified air apparatus consisting of activated charcoal.
2. Mount the **Low Range PCM** NO module in the ENERAC. Connect the probe to the ENERAC.
3. Turn the ENERAC on and Autozero using purified air. Set the range switch to the “low” position.

4. Feed the NO U.R.G. (Upper range calibration gas #2) for 15 minutes. If the display is off by more than 0.5% (**i.e. 4 ppm**) span calibrate the instrument.
5. Continue feeding the NO U.R.G. for one additional hour. At the end of the allotted time check the display reading. The reading must not differ from the U.R.G. value by more than 2% (**i.e. 17 ppm**).
6. Feed air to the unit and allow the no display to return to zero.
7. Feed the NO M.R.G.(#1) for five minutes. Check the display reading. It must not differ from the value of the M.R.G y more than 2% of u.r.g. (**17 ppm**).
8. Replace the Low Range NO PCM with the **Mid Range Pcm**.
9. Autozero the instrument. Set the range switch to the “**low**” position.
10. Feed the NO U.R.G. (Upper range calibration gas #4) for 5 minutes. If the display is off by more than 0.5% (**i.e. 2 ppm**) span calibrate the instrument.
11. Disconnect the instrument probe and feed the U.R.G. directly to the analyzer. Wait 5 minutes. The display reading without the probe must not differ from the previous reading by more than 5% of U.R.G.(**40 ppm**).
Reattach the probe to the instrument.
12. Feed air to the unit and allow the no display to return to zero.
13. Feed the NO M.R.G. (#3) for five minutes. Check the display reading. It must not differ from the value of the M.R.G. by more than 2% of U.R.G. (**9 ppm**).
14. Feed air to the unit and allow the no display to return to zero.
15. Set the range switch to the “**upper**” position.
16. Feed the NO U.R.G. (Upper range calibration gas #6) for 5 minutes. If the display is off by more than 0.5% (**i.e.17 ppm**) span calibrate the instrument.

17. Feed air to the unit and allow the NO display to return to zero.
18. Feed the NO M.R.G. (#5) for five minutes. Check the display reading. It must not differ from the value of the M.R.G. by more than 2% of U.R.G. (**70 ppm**).
19. Feed air to the unit and allow the no display to return to zero.

4. NO₂ sensor drift, calibration error, sampling sys. bias.

20. Make sure NO₂ display reads zero.
21. Feed the NO₂ U.R.G. (Upper range calibration gas #8) for 15 minutes. Observe carefully and time the response to the NO₂ gas. Determine the time in seconds when the response reached 85% of its final value. This is the NOX response time.
22. Record the display reading at the end of the 15 minute period. If the display is off by more than 0.5% (**i.e. 3 ppm**) span calibrate the instrument..
23. Continue feeding the NO₂ U.R.G. for one additional hour. At the end of the allotted time check the display reading. The reading must not differ from the U.R.G. value by more than 2% (**i.e.10 ppm**).
24. Disconnect the instrument probe and feed the U.R.G. directly to the analyzer. Wait 8 minutes. The display reading without the probe must not differ from the previous reading by more than 10% of U.R.G. (**40-50 ppm**).
Reattach the probe to the instrument.
25. Feed air to the unit and allow the no display to return to zero.
26. Feed the NO₂ M.R.G.(#7) for 8 minutes. Check the display reading. It must not differ from the value of the M.R.G. by more than 2% of U.R.G. (**10 ppm**).
27. Feed air to the unit and allow the NO₂ display to return to zero.

5. Interference tests

28. Install the NO Mid Range Pcm. Make sure the instrument is zeroed and calibrated. Feed the gases indicated in the table below and record the NO and NO₂ display readings.

All test gases must be within +/- 10% of indicated concentration.

TEST GAS	NO DISPLAY	NO ₂ DISPLAY
CO 500 PPM		
CO ₂ 10%		
NO 900-1000 PPM		
NO ₂ 450-500 PPM		
SO ₂ 200 PPM		
NO/SO ₂ MIXTURE 200 PPM/200 PPM		

29. The sum of the display readings for the NO sensor must be less than **50 ppm.**
30. The sum of the display readings for the NO₂ sensor must be less than **25 ppm.**

SUMMARY OF CTM-022.WPF REQUIREMENTS

1. SENSOR REQUIREMENTS

SECTION	SENSOR REQUIREMENTS
2.3.1	NO SENSOR TEMPERATURE < 30 DEG. C
4.6.1	NO LOW BOUNDARY > 50*BASELINE (20 C) IF BASELINE <2 PPM, NO LOW BOUNDARY > 20*BASELINE (20 C)
4.6.2	NO UPPER BOUNDARY: < 2% DRIFT, 1 HR. EXP. TO U.R.G. IF U.R.G. <100 PPM, <5% DRIFT, 1 HR. EXPOSURE
4.6.3	NO ₂ BASELINE < 0.1 uA (20 DEG. C)
4.6.3	NO ₂ DRIFT (1 HR. EXP. TO U.R.G.) < 2%

2. PROBE-TRANSPORT SYSTEM REQUIREMENTS

5.1.1	SAMPLE PROBE: GLASS, SS, INCONEL, HASTELLOY, NO CONDENSATION ALLOWED
5.1.2	TRANSPORT LINE: SS, TEFLON, VITON, NO CONDENSATION ALLOWED
5.1.3	MOISTURE REMOVAL SYSTEM: PERMEATION DRIER OR LOW LOSS CHILLER
5.1.4	PARTICULATE FILTER: SS, HASTELLOY, TEFLON, OR GLASS FIBER WITH FLUOROCARBON BINDER

3. CALIBRATION GAS REQUIREMENTS

6.1.1	ACCURACY: EPA PROTOCOL 1
6.1.2	ACCURACY: 2% CERT. CHECKED BY COMPARISON. (NO< 1YR. OLD, NO ₂ < 6 MO.)
5.2.1	(NO/NO ₂) UPPER RANGE GAS < 4* AVERAGE CONCENTRATION
5.2.2	(NO/NO ₂) MID RANGE GAS = 40% - 60 % OF U.R.G.
5.2.3	(NO/NO ₂) ZERO GAS = CHARCOAL PURIFIED AIR

4. INITIAL INSTRUMENT REQUIREMENTS

4.1	NO & NO ₂ :CALIBRATION ERROR < 2%, (ZERO, M.R.G., U.R.G.)
4.3	ZERO DRIFT < 3% OF U.R.G. FOR THE RUN
6.4.1.1	NO: SUM OF INTERFERENCES (CO, NO ₂ , SO ₂ /NO ₂ MIXTURE, CO ₂) < 5% OF U.R.G. OR 5 PPM.
6.4.1.2	NO ₂ : SUM OF INTERFERENCES (CO, NO, SO ₂ , CO ₂) < 5% OF U.R.G. OR 5 PPM.
3.7/6.2.1	RESPONSE TIME : L95 OF EQUAL MIXTURE OF U.R.G. NO & (50% OF U.R.G.NO) OF NO ₂ OR L85 OF U.R.G. NO ₂ (IF NO ₂ RT >5*NO RT)
4.2/6.5	NO: SAMPLING SYSTEM BIAS < 5% (OR 5 PPM) OF U.R.G. (1 RT WAIT) NO ₂ : SAMPLING SYSTEM BIAS < 10% (OR 5 PPM) OF U.R.G.(3 RT WAIT)

5. FIELD TESTING REQUIREMENTS

6.3	NO & NO ₂ :CALIBRATION ERROR < 2%, (ZERO, M.R.G., U.R.G. OR 5 PPM)- (1 RT WAIT)- <i>BEFORE</i>
6.4.2	NO: INTERFERENCE TO EACH (CO, NO ₂ , SO ₂ /NO ₂ MIXTURE, CO ₂) < 6% OF INTERFERING GAS, <i>BEFORE & AFTER</i>
6.4.2	NO ₂ : INTERFERENCE TO EACH (CO, NO ₂ , SO ₂ /NO ₂ MIXTURE, CO ₂) < 6% OF INTERFERING GAS <i>BEFORE & AFTER</i>
6.5	NO: SAMPLING SYSTEM BIAS < 5% (OR 5 PPM) OF U.R.G. (1 RT WAIT) NO ₂ : SAMPLING SYSTEM BIAS < 10% (OR 5 PPM) OF U.R.G.(3 RT WAIT) <i>BEFORE & AFTER</i>
6.6	CERTIFICATION PROTOCOL: RECORD OF SENSOR & FILTER PERFORMANCE BEFORE & AFTER EACH TEST
8.0	IF RUN < 1 HR: 1 READING/MIN. OR MINIMUM 20 IF RUN > 1 HR: 1 READING / 2 MIN. OR MINIMUM 96 (WAIT 3 NOX RT (7.2))
7.2.1/2.3.1	RECORD NO SENSOR TEMPERATURE < 30 DEG. C.
7.3	NO & NO ₂ DRIFT & SPAN: < 5% OF U.R.G. FOR ZERO & U.R.G. (FOLLOWING 1-3 RUNS. 2 RT WAIT)

B. VELOCITY MEASUREMENTS

1. Using the ENERAC probe assembly ((S-V) probe).

The ENERAC model 3000E meets all the requirements and specifications of the U.S. Environmental Protection Agency's 40CFR60 Appendix A, Method 2, "Determination of stack gas velocity and volumetric flow rate (type S pitot tube)".

Some basic requirements of the Method are listed below. For greater details see 40CFR60 Appendix A Methods 1 & 2.

The basic restrictions of the method are as follows:

1. An S type pitot tube is required whose dimensions must meet the specifications of Method 2. If the pitot tube meets the Method's outlined requirements (figures 2.1, 2.2 and 2.3 Method 2), then a pitot coefficient of 0.84 may be assumed without the requirement of an elaborate calibration system. Of course the analyzer must be properly zeroed and spanned before taking measurements.
2. The specifications of Method 1 requiring a minimum stack diameter of 12 inches and not significant cyclonic flow must be met. (See below how to use the ENERAC with small ducts).
3. A thermocouple is required to measure the stack temperature. Make sure that the ENERAC's thermocouple TIP does not touch the S type pitot tube to be consistent with the method's requirement.
4. The measurement device (manometer or other pressure transducer) must have a minimum resolution of 0.05" WC. The ENERAC's transducer is a highly sensitive piezocapacitive transducer having a resolution of 0.01" WC.
5. There is a requirement to measure the static pressure in the stack. The Method recommends disconnecting one end of the pitot tube (free end exposed to ambient) and orienting the pitot tube perpendicular to the flow, thus measuring the differential pressure between stack and ambient. This is

hardly necessary in most cases, since the difference in absolute pressure between ambient and most stacks is very small. If you need to do this, you can use the ENERAC, but you must compute the pressure ratio yourself from the apparent velocity indication of the ENERAC's display using the velocity formula:

$$\text{ACTUAL VEL.} = (\text{DISPLAYED VEL.}) / \text{SQRT}(1+0.000413*(\text{Va})^2/(460+\text{T}))$$

where,

T the stack temperature in degrees Fahrenheit,

Va the apparent velocity displayed by the ENERAC when one end of the pitot tube is disconnected and the other end aligned to zero flow,

SQRT square root function

DISPLAYED VEL. the velocity displayed by the ENERAC during your velocity measurement.

ACTUAL VEL. the velocity of the stack gases corrected for stack pressures very different from ambient.

It must be stated again, that this is a very minor correction and can be neglected for most cases.

The formula used in the ENERAC for the computation of stack gas velocity is equation 2-9, Method 2, Appendix A.

6. There is a requirement to measure the dry and wet stack gas molecular weight (for velocity calculations) and also the moisture content of the stack gas (for volumetric flow rate calculations). The ENERAC computes the molecular weight based on fuel ultimate analysis and excess air computations.

Even though the ENERAC computes the moisture content of the gases (needed for emission rate computations in lbs/hour required on a wet basis, the volumetric flow rate displayed by the ENERAC is measured on a wet basis, because this is the parameter that must be entered in the computation of emission rates in lbs/hour or tons/day (for CO₂) according to the requirements of 40CFR75.

The volumetric flow rate displayed by the ENERAC can also be corrected

for stack pressures very different to ambient as was outlined for velocity computations.

2. Measurement procedure.

1. Turn the analyzer on, connect the probe assembly to the analyzer. Check to make sure there is no physical damage to the S type pitot tube. Wait a few minutes for the instrument to warm up.
2. Make sure the thermocouple tip does not touch the pitot tube.
3. Autozero the instrument making sure that the probe is in still air.
4. Make sure the pitot coefficient is set to its default value of 0.84.
5. Insert the probe in the stack and measure the velocity head at the traverse points as specified by Method 1. You may have to twist the probe to locate the velocity null at each position, make sure it does not exceed 20 degrees from the stack orientation, then turn the probe 90 degrees for measurement.

NOTE: A convenient way to measure the average velocity in the stack and also the average value of the mass emissions is to use the ENERCOM FOR WINDOWS program to collect the data.

Determine the number of traverse points and locate them by marking the probe, or some other means before taking measurements. Allow 2-5 minutes of probe residence time per traverse and set the ENERCOM period equal to the residence time times the number of traverses. Start the program and move from traverse to traverse at the end of the predetermined time interval. At the end of the period the program will display the average stack velocity and also average values for the mass emissions (lbs/hour).

You can approximate the average velocity of the stack gases, without carrying out a number of traverses, by inserting the probe into the middle of the stack and multiplying the displayed velocity by 0.95.

6. At the end of your measurement, withdraw the probe from the stack and inspect again the S type pitot tube for any damage.

C. Velocity measurements in small stacks. (Method 2C).

If the stack diameter is smaller than 12 inches, the EPA recommends using a standard pitot tube for velocity measurements. The EPA does not recommend use of a conventional pitot tube assembly that combines extraction probe and thermocouple. You must therefore modify your testing procedure as follows (see figure 18)

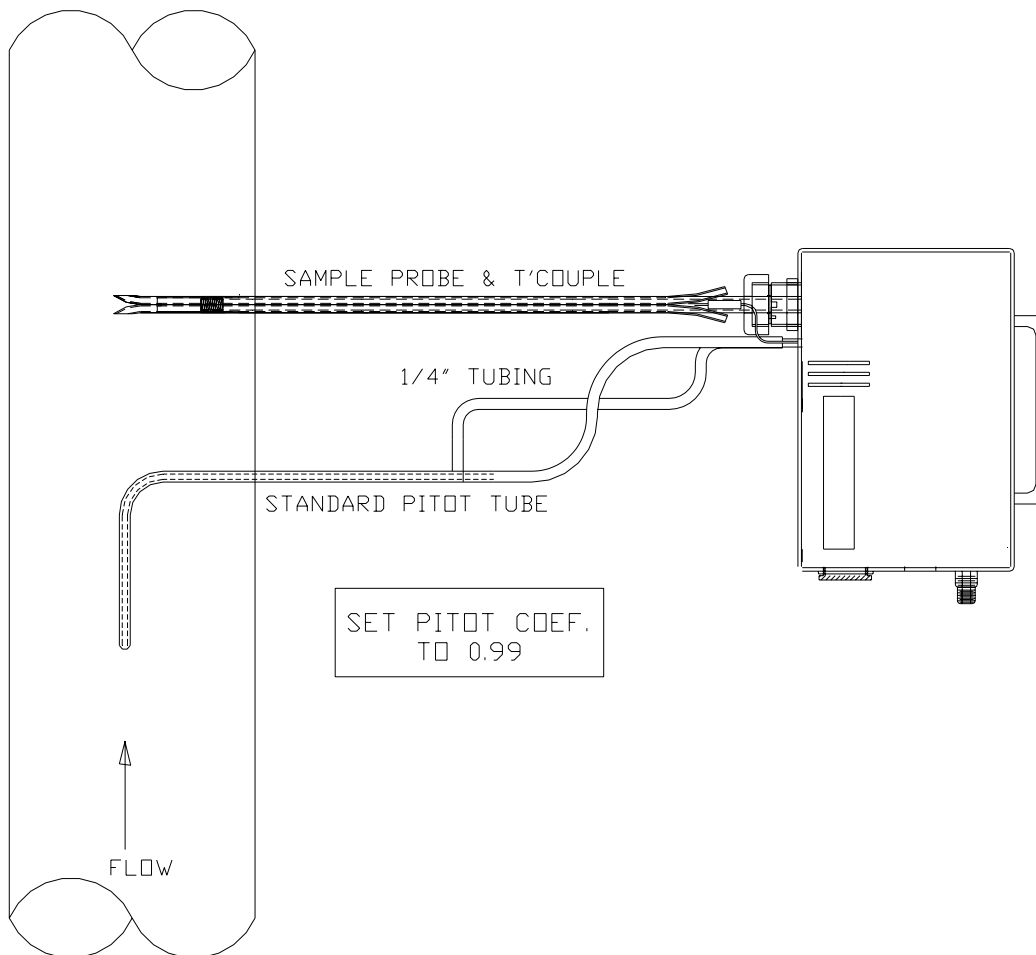

FIGURE 18

1. Disconnect the flexible tubing from the S type pitot tube.
2. Connect a standard type 1/4" OD. Pitot tube to the probe of the analyzer. Connect the stagnation pressure port of the pitot tube to the center most

velocity fitting (the one nearest the thermocouple connector). Connect the side port of the pitot tube to the other velocity fitting.

3. Turn the analyzer on by pass the auto zero procedure and set the pitot coefficient to 0.99 by using the “SET” and “STACK SIZE” keys in sequence.
4. Turn the unit off. Turn the unit on, allow a few minutes to warm up and autozero it.
5. Insert the probe and pitot tube in the stack through two different holes as shown in figure 16.
6. When you are finished with your measurement make sure that you set the pitot coefficient back to 0.84, if you intend to use the S type pitot tube next.

C. HYDROCARBONS MEASUREMENTS

EPA recommends using an NDIR analyzer for the measurement of gaseous hydrocarbons consisting primarily of alkanes (i.e. saturated hydrocarbons).

The results can be reported either as PPMv propane, or Ppv carbon using the conversion formula:

$$C_c = 3C_{\text{meas}}$$

where,

C_c = organic concentration as carbon, PPMv

C_{meas} = organic concentration PPMv propane (measured).

1. Calibration gases.

You will need high purity air (use the filtered air accessory supplied by Enerac), and three concentrations of propane in air or nitrogen. If you are using the 0 - 1.000 % NDIR cell, use 0.25%-0.35% propane as your low level gas, 0.45%-0.55% for your mid level gas and 0.80%-0.90% propane for your high level gas.

2. Pre test procedure.

You must use EPA Protocol 1 gases for the pre test procedure.

- a. Turn the instrument on and allow 5 minutes for the unit to warm up.
- b. Introduce the purified air to the analyzer and execute an auto zero. Make sure that no zero errors appear on the display.
- c. Introduce the high range calibration gas and calibrate the ENERAC following the procedure outlined in the chapter on calibration.
- d. Introduce the low level and mid level calibration gases to the analyzer and record the response of the ENERAC. The display readings must not differ by more than 5% from the respective calibration gas values.
- e. Reintroduce the high range gas to the analyzer and measure the analyzer's response time defined as the time required to reach 95% of its final reading. You should do this 3 times and average the result.

3. Field test procedure.

- a. Turn the ENERAC on and allow 10 minutes for warm up.
- b. Connect the high purity air filter to the ENERAC's probe and let the instrument aspirate air for 2 minutes. Auto zero the instrument.
- c. Obtain a supply of 2% certified mid range gas and feed the mid range gas to the analyzer and observe the display reading following two response times. Make any adjustments necessary.
- d. Insert the probe into the stack as close to the middle of the stack as possible. Begin sampling at the start of the test period recording time and any required process information as appropriate.
- e. Immediately following the completion of the test period and hourly during the test period reintroduce the zero and mid level calibration gases one at a time to the analyzer. Record the analyzer response. The zero and mid level

span drift must be less than 3% of the analyzer's span value (i.e. $< \pm 0.030\%$ for a 1.000% range).

APPENDIX A

ERROR MESSAGES & TROUBLESHOOTING

The ENERAC model 3000E is a sophisticated state of the art instrument designed for field use. It is, however, important that you should take proper care and avoid dropping it or exposing it to unusually high or low temperatures. Do not expose the probe to open flame and never use the instrument without the particulate filters.

The ENERAC model 3000E is always going through a self checking procedure every time it is turned on. Its crucial sensor performance is also thoroughly checked during every span calibration.

Occasionally, a problem may occur with the instrument. If this happens it will probably be due to one of the following components:

1. Sensor or sensor filter failure, or connection.
2. Discharged battery, or blown fuse.
3. Clogged filter, or damaged probe.
4. Thermal printer head failure.
5. Temporary memory corruption.

A. SENSOR PROBLEM MESSAGES

These messages may appear during AUTOZERO or following SPAN CALIBRATION.

1. Auto zero error.

If a sensor "XXX AUTOZERO ERROR" appears, the ENERAC will interrupt its initialization procedure and wait for the operator to decide if he wants to investigate the problem, or proceed by pressing the "ENTER" key.

An autozero error implies that the sensor's offset is outside its specifications.

- a. Make sure the probe is NOT inserted in the stack and that it is drawing ambient air during AUTOZERO countdown. If needed, use the rotometer

- to verify that air is being drawn into the instrument.
- b. Open the hinged section of the face plate and make sure that the proper PCB connector is mounted on the sensor.
 - c. Remove the sensor's PCM and make sure there is no moisture on its surface.
 - d. If it is a new sensor being installed, wait a few hours for the sensor to be properly biased.

2. Calibration errors.

Always look at the ENERAC's printout at the end of a span calibration. If a "REPLACE XX SENSOR....." message appears, check the following:

- a. Check first that you have entered into the ENERAC the correct value of the span gas that you are using. Check also that you are supplying the correct flow rate as indicated by the small flow meter supplied. Make sure there was sufficient span gas in the cylinder.
- b. Make sure that you do not use a gas mixture to calibrate the ENERAC. (The only permissible gas mixture is CO & CH₄).
- c. Make sure that the PCM that is mounted on the sensor is the same as that indicated by the display when you first turn the instrument on.
- d. If you are calibrating the NO₂ or the SO₂ sensor, make sure to feed the gas for at least 5 minutes before executing the span calibration procedure. These sensors are slow to respond.

B. POWER PROBLEMS

1. Display is blank, LEDS are off.

- a. Turn the instrument OFF, give a five minute charge to the battery, connect the AC cord to an outlet and turn the unit on. If the unit runs, charge the battery overnight and then run the instrument on battery. You should get at least 3 hours from a good battery. If not, you must replace the battery. Before replacing the battery make sure that the "AC CHARGE" LED turns on during battery charging.
- b. If the unit fails to operate, when plugged to an AC outlet, make sure the correct voltage (115 Volts or 220 Volts) is indicated on the ON-OFF switch assembly. Following this, check the AC fuse located on the left

hand side of the assembly.

- c. Open the hinged section of the face plate and look at the power connector located directly on top of the battery.

2. Instrument resets or turns off after a short time.

- a. Make sure battery is fully charged. BAT OK LED is not blinking. Connect to an AC outlet.
- b. Possible PC board problem. On or more pins of the EEPROMS is dislodged from its socket.

3. Instrument is locked.

- a. Make sure there is paper in the printer. Look for the following to appear on the display: "PRINTER PROBLEM".

C. FILTER AND PROBE PROBLEMS

Monitor the five LEDs located on the back of the probe case.

1. PROBE LED problems.

Monitor the five LEDs located on the back of the probe case.

2. "PROBE OK" LED problems.

The most common problem is associated with the green "PROBE OK" LED turning on.

- a. Connect the probe's electrical connection to the instrument.
- b. Wait at least two minutes for the probe to warm up.
- c. Make sure "HEATING/COOLING" LED turns ON RED. If not, there is a problem with the heat pump.
- d. Keep in mind that the ENERAC must heat the probe manifold to a temperature of 130-140 deg. F for proper operation of the water

conditioning system. *If the ambient temperature drops below 50 deg. F. the ENERAC's probe warm up time begins to lengthen, especially if the instrument is operated on batteries. Try using it on AC or using an external DC power source, such as a 12 Volt battery.*

- e. If the temperature drops below 25 deg. F. you must find a way to keep the probe reasonably warm. The unit will operate, of course, even if the "PROBE OK" LED is OFF, but you must watch carefully, the clear section of the hose for any signs of condensation.

3. Probe filter problems.

If the "BLOCKED FILTER" LED turns on, remove the probe from the stack. If the LED remains on, replace the fiber filter located on the side of the probe.

If the LED turns off, either the sintered filter requires cleaning, or the stack draft exceeds -15" W.C.. In the latter case, ignore the LED indicator.

If the "NO FILTER OR FLOW" LED turns on, make sure first that the sintered filter is in place at the tip of the probe.

Check the hose for any kinks, make sure the instrument sample pump is running and drawing a minimum of 500 cc/min. Check the flow rate with the probe removed. If the problem is inside the probe, it will have to be serviced at Enerac.

4. Probe heating/cooling problems.

During normal operation the "HEATING/COOLING" LED should cycle on and off every 2-5 minutes.

If it stays constantly on, it may indicate insufficient heating or cooling. Try to change ambient conditions to less extreme values. You can achieve this, probably, in a number of ways depending on the application. If this is not possible operate the instrument, but watch for any condensation.

5. Probe overheating problems.

If the "OVERHEATING" LED turns ON, *REMOVE PROBE FROM STACK AT ONCE AND INVESTIGATE.*

Proceed as follows: Move the probe housing further from stack wall. Make sure to use the ENERAC's heat shield.

In engine measurements, avoid placing the probe directly in front of the exhaust blast!

Make sure bicolor LED is on GREEN!

- 6. Condensation problems.** During a measurement you must always watch the clear section of the hose for any condensation. This is very important for NOX measurements, especially if you suspect the presence of NO₂.

If you observe condensation in the hose, proceed as follows:

- a. Your conditioning system will be overwhelmed, if water or steam is injected in the stack. Contact Enerac for suggestions. (You may want to add the secondary drier model 1128 to your system).
- b. Make sure the exposed section of the inconel probe is hot (Approximately too hot to the touch).
- c. Try to keep the probe case warm, especially if the "HEATING" LED stays constantly on.
- d. Reduce the sample pump flow rate by 100 cc/min. then by another 100 cc/min. if necessary.

To reduce the pump speed, open the hinged section of the face plate and locate the sample valve under the PC board near the printer paper. Use the small flow meter supplied to you to monitor the flow rate.

D. OTHER PROBLEM MESSAGES

ERROR MESSAGE

WHAT TO DO

"CONNECT PROBE-RESTART"	Make sure the probe electrical connection is connected to the instrument.
"STEMP AUTOZERO ERROR"	Make sure probe was at ambient temperature when the unit was autozeroed. Check for an open thermocouple. Check couple electrical resistance (~10 ohms).
"COMB AUTOZERO ERROR"	Sensor needs additional warm up period. Restart unit. Sensor response is out of original specs. Sensor is probably OK. Check with calibration gas. Sensor was damaged by excessive moisture or comb.gas.
"OVER"	Make sure you are using the correct Precision Control Module. Make sure the ENERAC is set for the correct PCM.

E. WARNINGS

The ENERAC has been designed to perform a number of diagnostic tests, while carrying out stack measurements.

If, during operation, it detects any conditions that will jeopardize the integrity of the instrument or its readings, it will warn the operator by displaying every 30 seconds a message that describes the nature of the warning. These messages, if activated can also be monitored remotely by using the WARN? command.

A list of the warning messages follows:

WARNING MESSAGE

WHAT TO DO

ALL DISPLAY POINTER LEDS
TURN ON AND BEEPER BEEPS

*REMOVE IMMEDIATELY THE PROBE
FROM THE STACK.*

This is an indication that one or more of the ENERAC sensors has over ranged and there is a danger of saturating the sensor. The following message will appear on the display:

“XXX SENSOR OVER-RANGE”

"AMBIENT TEMP TOO HIGH"	Check connection of thermocouple plug to instrument. Remove ENERAC from immediate vicinity to avoid sensor failure because of high ambient temp.
"STEMP HIGH EXTRACT PROBE"	Remove probe from stack to avoid damage to the thermocouple.
"CO HIGH EXTRACT PROBE"	Remove probe to avoid temporary failure of the CO sensor.
"REPLACE BLOCKED FILTER"	Excessive suction pressure. Check filter or hose for kinks.
"CO EXCEEDS ALARM"	The CO in the stack exceeds the preset alarm value.
"PRINTER PROBLEM"	Check printer paper, or printer connections.
"RS-232 PROBLEM"	Improper initialization at start up. Ignore unless you require serial communication. In that case, turn unit off then back on again. Bypass autozero.
"MODEM ON LINE"	A reminder that the ENERAC is still connected to the phone line.
"...OVER....."	Value of stack parameter exceeds upper range limit. <i>Exception: emissions lbs/MBTU aspirating air.</i>

"OPTIONAL....."

This option is not available in your unit.
Contact the factory.

F. MISCELLANEOUS PROBLEMS

SYMPTOM

WHAT TO DO

Oxygen too high in stack

1. Check for kinked hose.
2. Check for clogged filter.
3. Tighten thumbscrew on probe handle.
4. Check for high draft.
5. Tighten housing cover.

Response too slow.

1. Check for clogged filter.
2. Check the pump flow rate. It should be 700-800 cc/min.
3. Check for air leaks.
4. NO₂ & SO₂ sensors have slow responses.

G. PRINTER PROBLEMS

SYMPTOM

WHAT TO DO

Printer does not run.

1. Make sure there is paper in the printer.
2. Make sure paper goes through paper check sensor.

Missing dots on letters.

1. Replace thermal head.

G. MEMORY PROBLEMS

SYMPTOM

WHAT TO DO

Strange characters appear on display or instrument locks.

1. Turn instrument off and then on

APPENDIX B

MODEL 3000E SPECIFICATIONS

NOTE: The ENERAC model 3000E meets all the requirements of EPA's EMTIC CTM-022.WPF for the measurement of NOX emissions.

PHYSICAL:

1. CASE
18"X13"X6" Aluminum carrying case with lock. Weight: 18 lbs.
2. EMISSIONS PROBE
24"L. X 3/8" OD. Inconel probe with Hastelloy X sintered filter and 1/2" deflector mounted on permeation drier housing. Probe housing connects to instrument via a 10 ft. Viton hose.
Max. continuous temperature: 2000 deg. F.
Max. sample dew point (past drier) 50 deg. F.@ 600 cc/min. (Natural gas fuel @ 0% oxygen).
3. VELOCITY-EMISSIONS PROBE ASS'Y (Optional)
Three part stainless steel detachable welded assembly. Consists of 3/8" OD sample probe with sintered filter, two sections of 3/16" S type pitot tube and inconel sheathed type K thermocouple. Standard length 17". (Specify desired size of optional length). Max. Continuous temperature: 1700 deg. F.

ELECTRICAL POWER:

1. INTERNAL BATTERY
6V. rechargeable sealed lead-acid cell. Three - four hour continuous battery operation depending on ambient temperature. Quick 6 hour recharge.
2. AC
120V. 60 Hz. and 220V. 50 Hz., selected by switch.

3. DC

External 6Volt, 10 AH battery. External battery can be recharged directly by the ENERAC, or any 11-40 VDC / 5A source. (Use special cable supplied).

DISPLAY:

0.35" high by 24 Character two line LCD with back-light illumination and adjustable viewing angle. Simultaneous display of any four emission parameters or two messages.

MEASURED PARAMETERS:

1. AMBIENT TEMPERATURE

IC sensor. Degrees F or C.
Range: 0-150 degrees F
Resolution: 1 degree F or C.
Accuracy: 3 degrees F

2. STACK TEMPERATURE

Type K thermocouple. Degrees F or C
Range: 0-2000 degrees F (1100 C).
Resolution: 1 degree F.(1 C.)
Accuracy: 5 degrees F.

3. OXYGEN

Electrochemical cell. Life 2 years.
Range: 0-25%
Resolution: 0.1%
Accuracy: 0.2%

4. NITRIC OXIDE (NO)

Electrochemical (SEM™) cell. Life: Approximately 3 years.
PCM Ranges: 5-300 PPM.
0-1000 PPM (300-1000)
0-3500 PPM (1000-3500)
or 5000 PPM (request)

Resolution: 1 PPM
Accuracy: 2% of reading (*)

5. NITROGEN DIOXIDE (NO₂)

Electrochemical (SEM™) cell. Life: Approximately 3 years.
Range: 0-500 PPM.
0-1000 PPM (special order)
Resolution: 1 PPM
Accuracy: 2% of reading (*)

6. CARBON MONOXIDE

Electrochemical (SEM™) cell. Life: Approximately 3 years.
PCM Ranges: 0-500 PPM
0-2000 PPM (500-2000)
0-20000 PPM (2000-20000)
or 40000 PPM (request)
Resolution: 1 PPM
Accuracy: 2% of reading (*)

7. SULFUR DIOXIDE

Electrochemical (SEM™) cell. Life: Approximately 3 years.
PCM Ranges: 0-500 PPM
0-2000 PPM (500-2000)
0-7000 PPM (2000-7000)
Resolution: 1 PPM
Accuracy: 2% of reading (*)

8. COMBUSTIBLES (GASES) (HC option replaces it)

Catalytic sensor. Life indefinite.
Range: 0-6.00%
Resolution: 0.01%
Accuracy: 10% of reading in CH₄ gas

9. TIME/DATE

Time in hours, minutes, seconds.
Date in month, day, year format.

(*) When tested according to 40CFR60, RAA test.

(Oxygen correction factor for emissions adjustable 0-20% in 1% steps plus TRUE).

10. VELOCITY (Optional)

S type pitot tube (std).
Range: 0-200 ft/sec. (2" WC)
Resolution: 1 ft/sec
Accuracy: Meets EPA Method 2

ENERAC'S PROPRIETARY LED BASED NON-DISPERSIVE INFRARED (NDIR) TECHNOLOGY OPTIONS

1. HYDROCARBONS (NDIR) (Optional)

Exclusive solid state LED based NDIR has exceptional life and stability. Available for propane calibrated and methane calibrated modes.
Range: 0-5% and 0-1% by volume.
Resolution: 0.001 %
Accuracy: +/- 5% of reading or 0.01% volume (whichever is greater).

2. CARBON DIOXIDE (NDIR) (Optional)

Exclusive solid state LED based NDIR has exceptional life and stability
Range: 0-20 %
Resolution: 0.1%
Accuracy: +/- 5% of reading

ENERAC'S PROPRIETARY - BATTERY OPERATED THREE GAS NDIR AUTOMOBILE AND DIESEL TESTING OPTION

Unit includes CO-CO2 and Hydrocarbons

1. CARBON MONOXIDE

Range: 0.01 % to 10.0 %
Resolution: 0.1 %
Accuracy: 5 % of Reading

2. CARBON DIOXIDE

Range: 0 - 16 %
Resolution: 0.1 %
Accuracy: 5 % of Reading

3. HYDROCARBONS

Range: 0- 10,000 PPM

Resolution: 1 PPM
Accuracy: 2,000 - 5,000 PPM 5% of Reading
5,000 - 10,000 PPM 10% of Reading

COMPUTED PARAMETERS:

1. COMBUSTION EFFICIENCY

Heat loss method. Unique four loss factors computation.
(dry gas, water vapor, gaseous combustibles, combustibles in ash)
Range: 0-100%
Resolution: 0.1%
Accuracy(4 loss): 1% (above H₂O condensation), 2% (below H₂O condensation)

2. CARBON DIOXIDE

Range: 0-40%
Resolution: 0.1%
Accuracy: 5% of reading.

3. EXCESS AIR

Range: 0-1000%
Resolution: 1%
Accuracy: 10% of reading

4. OXIDES OF NITROGEN

PCM Ranges: 0-800 PPM.
0-1500 PPM (800-1500)
0-4300 PPM (1500-4300)
or 5500 PPM (request)
Resolution: 1 PPM
Accuracy: 2% of reading (*)

5. EMISSIONS 1 (CO, NO, NO₂, NOX, SO₂)

Range: 0-2500 milligrams/cubic meter
Resolution: 2 mg/m³
Accuracy: 5% of reading

6. EMISSIONS 2(CO, NO, NO₂, NOX, SO₂)

Range: 0.000-99.99 lbs./million BTU
Resolution: 0.01 lbs./MMBTU
Accuracy: 5% of reading

7. EMISSIONS 3(CO, NO, NO₂, NOX, SO₂)
Range: 0-99.99 grams/brake hp-hr
Resolution: 0.01 grms/bhp-hr
Accuracy: 10% of reading

8. EMISSIONS 4 (CO, NO, NO₂, NOX, SO₂) (Optional)
Range: 0-99.99 lbs./hour
Resolution: 0.01 lbs./hour
Accuracy: 10% of reading
(CO₂)
Range: 0-99.99 tons/day

9. STK GAS FLOW RATE (Optional)
Range: 0-65000 cub.ft/min.
Resolution: 1 cfm
Accuracy: Meets EPA Method 2

PRINTER:

SEIKO 4",40 char. per line thermal printer with form feed and line feed buttons and with end of paper override.

Operates in any of four print modes:

1. TEXT MODE
25 line printout of instant. values of all measured parameters. (time req.20 sec.)
2. PLOT MODE
Any one parameter vs. time plotted.
3 ordinate scales: full, half, quarter.
Time scale: Selectable, 1 sec/dot-1 min/dot in 1 sec/dot intervals.
3. CALIBRATION PROTOCOL

Automatic printout of both auto zero and span calibration test results, including sensor diagnostics and filter operation.

4. EXTERNAL PRINT MODE
Prints messages sent via RS-232 port.

STORAGE:

1. INTERNAL
50 individually selectable buffers hold one complete set of measurements each in non volatile memory. Buffer contents can be sent to printer or RS-232 port.
2. EXTERNAL (Optional)
See software.

COMMUNICATIONS:

1. RS-232 PORT
RS-232c port (switch selectable DTE or DCE), 300-9600 (1200 default) baud, user selectable, half duplex, 1 start bit, 8 data bits, 1 stop bit, no parity.
2. TELEPHONE PORT
Internal 1200 baud modem connects to a modular phone line for remote communication.
(A 50 word command set sends instructions to the unit for remote control and troubleshooting).
3. ANALOG OUTPUTS
Eight analog outputs, 0-5 VDC, of the following parameters: stack temperature, ambient temperature, oxygen, combustibles, carbon monoxide, nitric oxide, nitrogen dioxide and sulfur dioxide.

SOFTWARE

ENERCOM for Windows™ software

3 1/2" diskette includes ALL PARAMETER MONITOR, ALARMS, CUSTOM FUEL PROGRAMMING, BAR GRAPHS and MULTIPLE LINE PLOTS including CUMULATIVE PLOTS of mass emissions..

MISCELLANEOUS:

1. FUELS
15 fuels, 3 in foreground, 12 in background standard. Custom fuels available on request or by ENERCOM programming. (Oxygen correction factor for emissions adjustable 0-20% in 1% steps plus TRUE)..
2. CO ALARM
Selectable 0-2000 PPM in 10 ppm steps.
3. COMBUSTIBLES IN ASH
Pretable 0-100% in 5% steps.
4. MESSAGES
One hundred diagnostic and help messages.
5. CALIBRATION
Optional Autozero on start up. Software span calibration CO, NO, NO₂, SO₂, combustibles.

APPENDIX C

ENERAC MODEL 3000E OPERATING KEYS

1. **“ENERAC”**. It is the trademark of all emissions analyzers manufactured by Enerac, Inc.
2. **Thumbscrew** . It allows opening of the hinged section of the face plate for easy access to the sensors and printer paper.
3. **Electrical probe connection**. The electrical cable from the probe connects here. Also here is where the ambient temperature sensor located.
4. **Sampling hose connection**. Stack gas enters the analyzer here through quick connect fitting.
5. **Gas Exhaust outlet**. Stack gas exits the analyzer here. Do not block this opening.

POWER SECTION

6. **ON/OFF switch**. Toggles the instrument on (- position), or off (o position).
7. **115/230 VAC switch**. Selects the mains voltage for either 115 VAC or 230 VAC operation. To change selection, lift the switch assembly cover and pull out the voltage selector. Turn it to the desired voltage and place it back in its housing.
8. **AC power connector**. Use the cable supplied with the ENERAC to connect to an AC power source and operate the analyzer. Use it to charge the analyzer’s internal battery.
9. **External DC power connector**. Use the cable provided with the ENERAC to power the analyzer from an external 11-36 volt source. Use the adaptor provided, to power the analyzer from an external 6 volt battery (supplied by Enerac). You may also charge the external 6 volt battery through this connector.

10. **Battery OK LED.** When the internal battery is nearly discharged, the light will begin to flash. You have approximately 10 minutes of battery life left.
11. **Charge LED.** When it is on, it indicates that the analyzer's battery is being charged. It will turn off when the battery becomes fully charged.

DISPLAY AND LED DESCRIPTION

12. **Two line by 24 character backlit LCD display.** Each line is divided into two sections, so that the ENERAC displays four stack parameters simultaneously.
13. **Viewing angle potentiometer.** Rotate this potentiometer for optimum viewing of the display.
14. **Fuel selector indicator LED.** One of three fuel LEDs. The one lit indicates the current fuel selection.
15. **Display Pointer LED.** When lit, it points to the one of the four sections that the display is divided into, where the selected parameter chosen by pressing one of the stack keys will be shown. It also points to the parameter that will be plotted, if the "PLOT" key is pressed.
16. **"SET" Key LED.** When lit, it indicates that the keys on the face plate operate in their second function (similar to a calculator's second function key), which is printed on the labels that are directly below or above each key. When it is off, the keys operate in their normal mode.
17. **Output LED.** When it is lit, it indicates that the ENERAC is currently sending data to a computer, either directly or through its internal modem.

OUTPUT CONNECTIONS

18. **Standard telephone jack.** Use a standard phone cable to connect the ENERAC to a DEDICATED phone line. When the analyzer is on, it will automatically answer the phone. Use it for remote communication between computer and the ENERAC.

19. **Serial communications port.** Use a standard 9 pin serial cable to connect directly to a computer's serial port. Use the ENERCOM for Windows software to greatly expand the analyzer's data handling capabilities. For proper communications make sure that both analyzer and computer are set for the correct handshaking.
20. **Analog output.** 0-5 volt analog outputs of all 8 stack parameters. It can be used to connect to an analog recorder, or control devices.

THE ENERAC KEYS. MAIN FUNCTION

21. **Display Selector Key.** Press this key to select the display's "active" section as indicated by the corresponding LEDs.
22. **Fuel selector key.** Press any of the three keys to select the current fuel. The selected fuel is shown on the display.
23. **Temperature display key.** Press this key to display the stack temperature. Press it again to display the ambient temperature. This key toggles to display alternatively stack and ambient temperatures.
24. **Oxygen display key.** Press this key to display the concentration in % of the oxygen in the stack.
25. **CO/SO₂ display key.** Press this key to display the concentration of carbon monoxide in the stack. Press it again to display the concentration of sulfur dioxide in the stack. This key toggles to display alternatively CO and SO₂.
26. **Combustibles OR hydrocarbons display key.** Press this key to display the concentration of gaseous combustibles measured as % methane in the stack. Measurement range is 0.1% - 6%.

If you have the NDIR (non dispersive infra red) hydrocarbons option the LCD will display the concentration of hydrocarbons as % propane. Measurement range is 0% - 1.00% in 10 ppm increments.

27. **CO₂/excess air key.** Press this key to display the computed value of the concentration of carbon dioxide in %. Press this key again to display the

computed value of the excess air. This key toggles alternatively between CO₂ and excess air. Both values are computed on the basis of the oxygen concentration and the fuel selected.

28. **NO/NO₂ display key.** Press this key to display the concentration of nitric oxide (NO) in the stack. Press it again to display the concentration of nitrogen dioxide (NO₂) in the stack. This key toggles to display alternatively NO and NO₂.
29. **NOX display key.** Press this key to display the total oxides of nitrogen (i.e. NO + NO₂) concentration.
30. **Efficiency/Velocity display key.** Press this key to display the computed value of the combustion efficiency of boilers or furnaces (not valid for computing efficiency of engines or turbines). Press it again to display the velocity of the stack gases. This key toggles alternatively between efficiency and stack gas velocity.

OUTPUT KEYS

31. **Time / Date display key.** Press this key to display simultaneously the ENERAC's time and date.
32. **“Print” key.** Press this key to obtain a printout of the current data, including time, fuel selected and sensor information.
33. **“Plot” key.** Press this key to start a plot on the ENERAC's printer of the stack parameter indicated by the LED display pointer. Press this key again to stop the plot.
34. **Output key.** Press this key to send ASCII data through the ENERAC's serial port to a connected computer. The data format is the same as it appears on the printer.

DUAL RANGES

35. **Dual range switches (CO, NO, SO₂).** Momentary toggle switches. When any switch is toggled UP, the corresponding LED turns on, the intrinsic sensitivity

of the sensor is reduced to allow measurement of high concentrations. When the switch is toggled DOWN, the corresponding position indicating LED turns on, the sensitivity of the sensor is increased to carry out accurate low concentration measurements. Standard dual ranges are: (CO: 2000/20,000 PPM; NO: 1000/4000 PPM; SO₂: 2000/6000 PPM. NO₂: 500 PPM (single range)).

THE “SET” KEY FUNCTIONS:

36. **The “SET” key.** This operates as a 2nd function key, as in many calculators. Press this key to enter the “SET” mode, (See LCD display), and change the function of the ENERAC keys to those listed outside the corresponding buttons. The LED located directly above the “SET” key will stay on as long as you are in the “SET” mode. Press this key again to exit the “SET” mode.
37. **The “UP”/”DOWN” keys.** These key operate on the “SET” mode only. They function to increment/decrement the digit highlighted by the blinking cursor, or to change the selected parameter to another one (ex. Change units from PPM to MGM).
38. **The “ENTER” key.** When the LCD displays to different parameters on its top line, this key serves as a “shift” key to shift the cursor from the left side to the right side of the display. When one parameter only is displayed or when the cursor is located on the right side of the display, pressing this key results in entering (i.e. accepting) the selected parameter and exiting the “SET” mode.

THE ENERAC KEYS. “SET” (2ND FUNCTION) OPERATION.

39. **“SET” fuels key.** Press any of these three identical keys to display the ENERAC’s 15 background fuels. Use the “UP”/”DOWN” keys to select the desired fuel and then press the “ENTER” key.
40. **“SET” degrees F/C- “Comb. Air” key. (*Dual set key*).** Press this key to change the ENERAC’s temperature units from degrees Fahrenheit to degrees Celsius (left side of the display), OR the preheat air temperature (if air is combustion air is preheated) (right side of the display). To make the changes use the “UP”/”DOWN” keys and use the “ENTER” key to shift to the right side of the display and to exit the “SET” mode.

41. **“SET” Emissions Units key.** (*Dual set key*). Press this key to select the desired units of measurement for the gas sensors (i.e. PPM, milligrams/m³, lbs/MMBTU, grams/HP-Hr, lbs./hour) (left side of the display), OR the oxygen reference value (if other than “true” is desired) (right side of the display. To select the changes use the “UP”/”DOWN” keys and use the “ENTER” key to shift to the right side of the display and to exit the “SET” mode.
42. **“SET” CO alarm key.** Press this key to enter the desired value of the carbon monoxide audio visual alarm in units of PPM only. Use the “UP”/”DOWN” and “ENTER” keys as described above.
43. **“SET” Ash residue key.** Press this key to enter the amount of combustibles in the ash (determined by other means). This key functions for solid fuels only. Use the “UP”/”DOWN” and “ENTER” keys as described above.
44. **“SET” Module select key.** (*Dual set key*). If you change the Precision Control Module (PCM) on any of the CO, NO, SO₂ sensors YOU MUST INFORM THE ENERAC OF THIS CHANGE. Press this key to display the current PCMs. Use the “UP” / “DOWN” key to select the appropriate sensor, whose PCM you have changed; press the “ENTER” key to shift to the right side of the display; change to the selected PCM (L or M) by pressing the “UP” / “DOWN” key and finally press the “ENTER” key to accept the changes and exit the “SET” mode.
45. **“SET” Spans (Calibration) key.** Press this key to initiate the ENERAC’s calibration procedure, which requires that you have the needed span gas cylinders ready for calibration. By pressing the “ENTER” key and the “UP/DOWN” key you make your selection, which sensor to calibrate and you also tell the ENERAC the concentration of the span gas you are using.
46. **“SET” Pump ON/OFF key.** Press this key to turn off the ENERAC’s main sampling pump. Press it again to turn the pump on. This key does not affect the probe’s counterflow pump, which is always on!
47. **“SET” Stack size key.** (*Triple set key*). Press this key to enter the cross sectional area in sq. in. of the stack, which is needed for mass loading calculations (left side of the display), OR switch the units of velocity

measurement from FPS (ft/sec.) to CFM (cu .ft./min.) (Right side of the display). To select the changes use the “UP”/”DOWN” keys and use the “ENTER” key to shift to the right side of the display and press again the “ENTER” key again to select the pitot coefficient and finally to exit the “SET” mode.

48. **“SET” Time/Date key.** Press this key to change the time or date of the ENERAC’s clock.
49. **“SET” Store key. (Triple set key).** Press this key to store (or retrieve) emissions data into the ENERAC’s internal storage buffers. The left side of the display indicates the current storage buffer number. The right side of the display allows you to switch from STORE, DUMP, PRINT, ERASE etc. and by pressing the “ENTER” key again you select the source’s identification number.
50. **“SET” Plot Scale key. (Dual set key).** Press this key to select the scale of the ENERAC’s printer plotter vertical ordinate (left side of the display), OR the plotting speed (right side of the display). To make the changes use the “UP”/”DOWN” keys and use the “ENTER” key to shift to the right side of the display and to exit the “SET” mode.
51. **Paper feed button.** Press this button down once to advance the printer paper one line at a time.

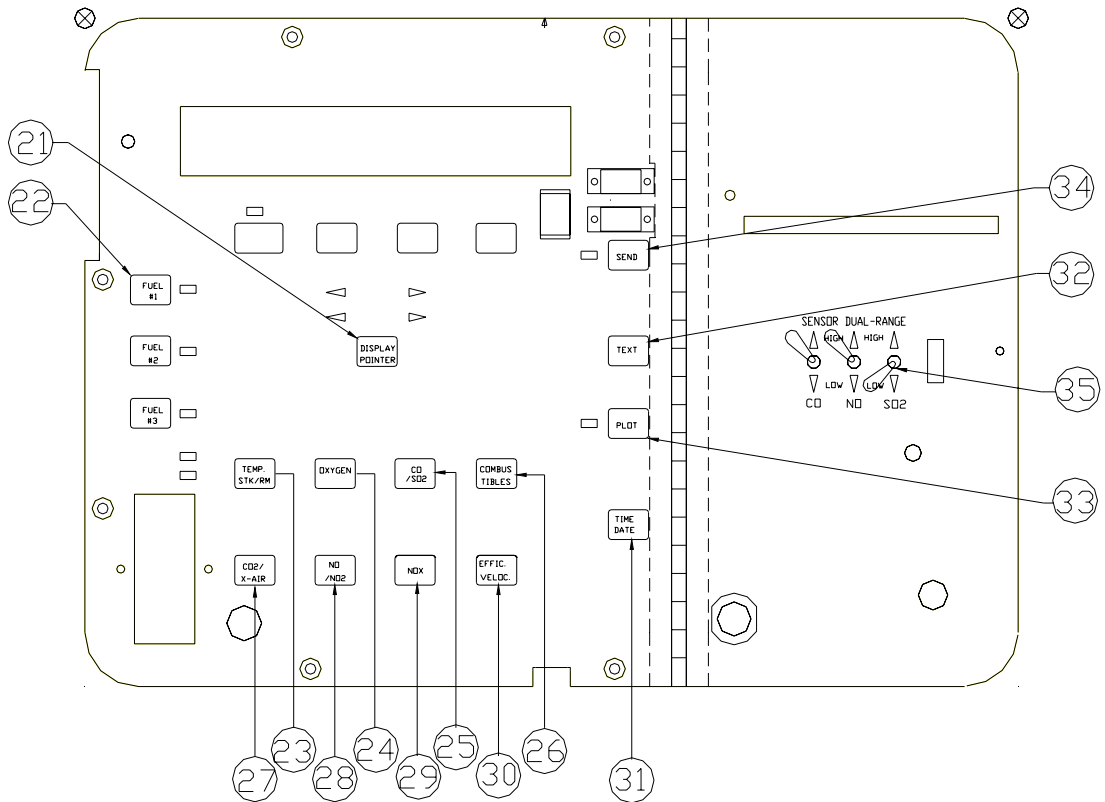
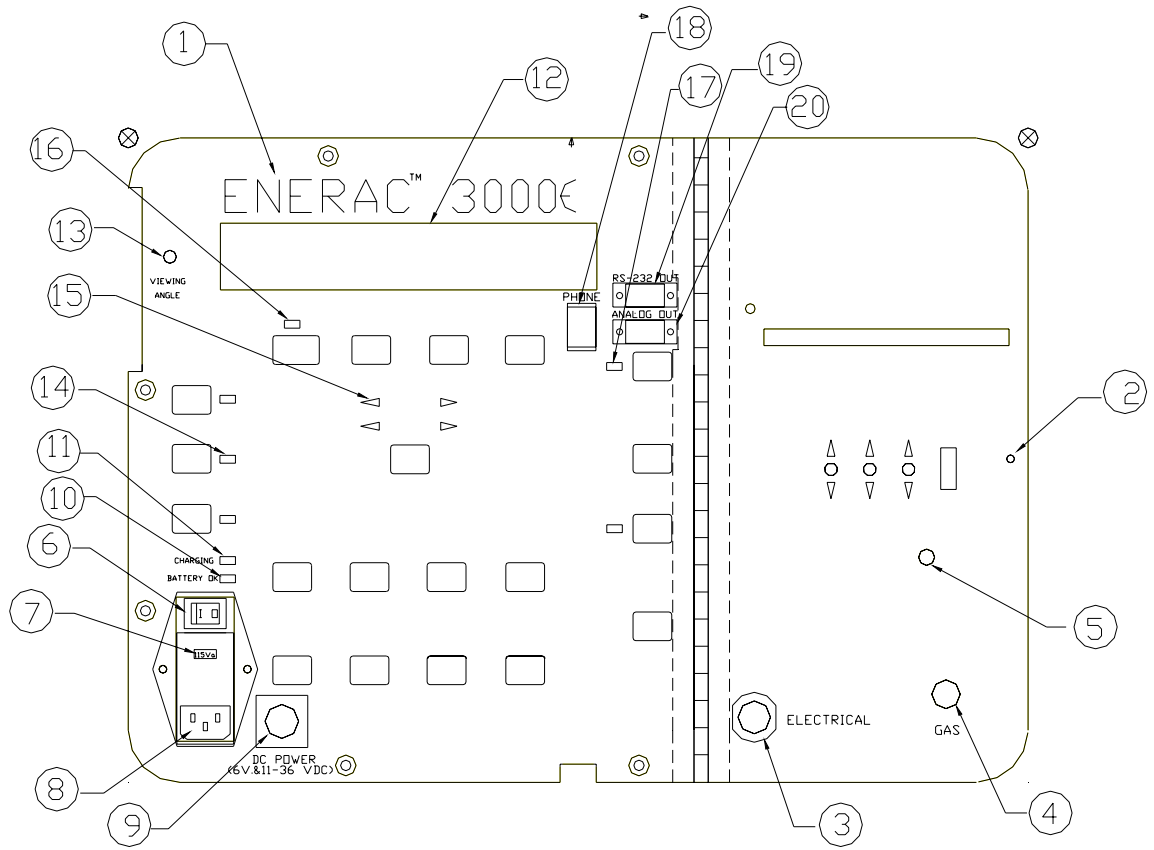

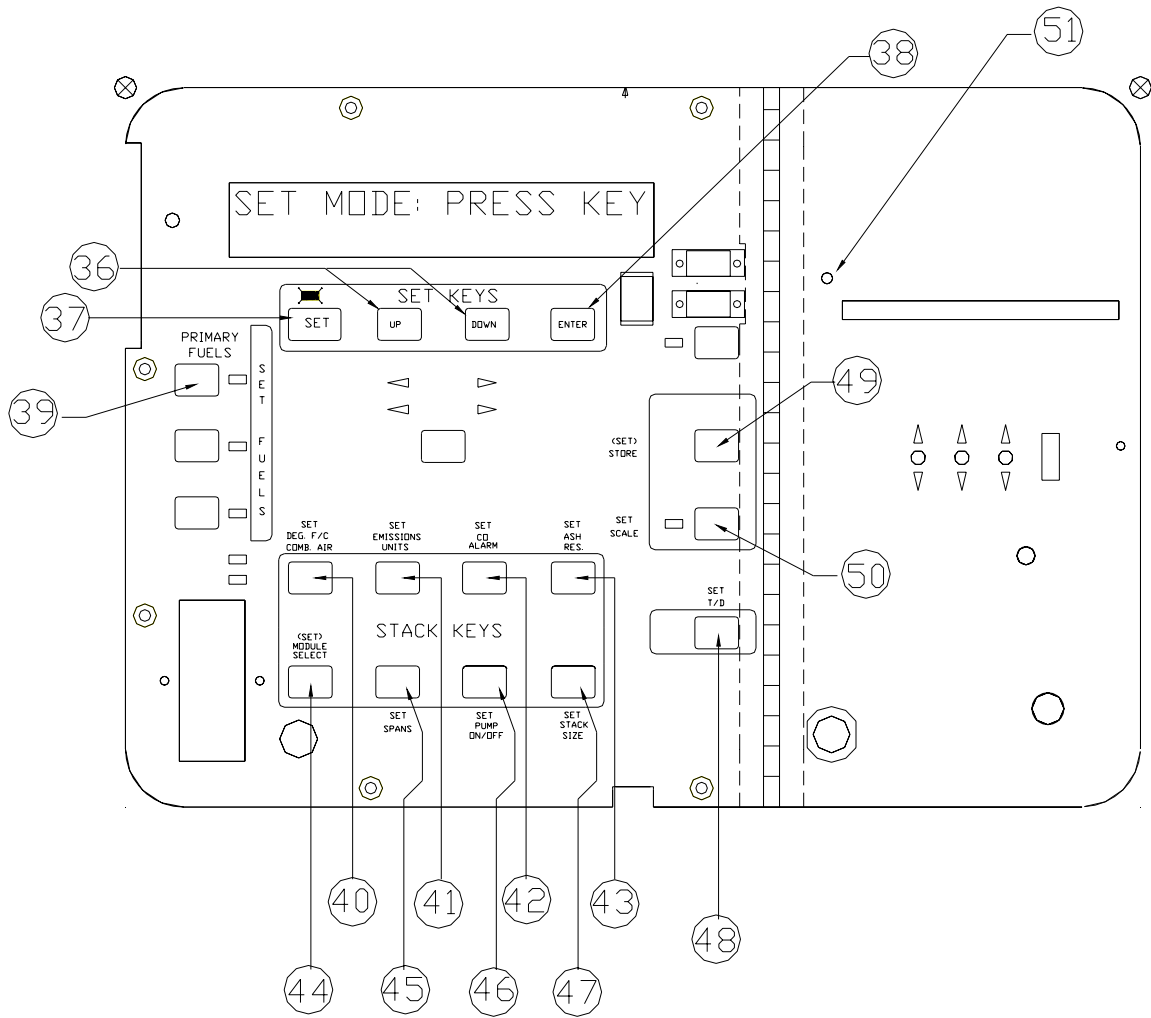

APPENDIX D

CORRECTION FOR AMBIENT OXYGEN CONCENTRATION

One of the unique features of the Enerac 3000 is that it has an oxygen calibration adjustment. This is important if you are calculating mass emissions. If the oxygen value is high then there is a possibility that your mass emissions can be over stated. To allow you to ensure that you have accurate measurements and properly calculated mass emissions the Enerac has included an ability to fine tune the oxygen cell.

CAUTION:

Before you make any oxygen adjustments, please make sure you understand the following description.

When the ENERAC is auto zeroed in clean ambient air, the concentration of oxygen is set to 20.9%, which is the volumetric concentration of oxygen (20.948%) in DRY (i.e. zero relative humidity) air.

However, when the relative humidity of ambient air is relatively high the concentration of oxygen in ambient air may decrease from its dry air concentration significantly.

The table below shows the oxygen concentration in ambient air for different values of ambient temperature and relative humidity.

RELATIVE HUMIDITY	AMBIENT TEMPERATURE DEG. F.					
	50	60	70	80	90	100
0%	20.95	20.95	20.95	20.95	20.95	20.95
10%	20.92	20.91	20.89	20.87	20.85	20.81
30%	20.87	20.84	20.79	20.73	20.65	20.54
50%	20.82	20.77	20.69	20.59	20.46	20.27
70%	20.77	20.69	20.58	20.45	20.27	20.13
90%	20.72	20.62	20.48	20.31	20.07	19.74
100%	20.69	20.58	20.44	20.23	19.98	

To correct the ENERAC oxygen reading of the ambient air concentration, you must know the relative humidity of the ambient air AS IT REACHES THE

OXYGEN SENSOR and the ambient temperature. The latter can be read from the ENERAC. To measure the relative humidity of the air reaching the oxygen sensor you must connect an RH meter between the sample line and the analyzer and measure the RH of the air entering the analyzer. Bear in mind that this relative humidity may undergo small changes during measurements.

NOTE: The change in the volumetric concentration (i.e. % by volume) of oxygen with altitude is negligible up to 70,000 ft. and therefore the ENERAC sensor, which measures oxygen concentration as % by volume, does not require any correction for altitude.

To carry out an oxygen sensor adjustment proceed as follows:

- Turn the ENERAC on.
- Push the "SET" button and observe "SET" LED turn on.
- Push the "NO/NO2" button. (You now enter the calibration mode). The following message will appear:

CMB SPAN GAS: 0.11%

- By pass all toxic gas calibrations and also the ambient temperature calibration as explained in the chapter on calibration, until the following message appears on the display:

AMBIENT O2: 20.9%

- Look at the table above and determine the correct oxygen concentration based on the ambient temperature and relative humidity, as explained.
- Use the "UP"/"DOWN" keys to set the oxygen concentration to the value obtained from the table. Then press the "ENTER" key.
- The ENERAC will store in its memory this new value and will display it every time the instrument is drawing ambient air, even after it has been turned off!

NOTE: Remember to check the ENERAC's display of oxygen concentration each time you turn on the instrument.

APPENDIX E

DETERMINATION OF THE EXACT NO AND NO₂ FRACTIONS OF NOX

At temperatures in excess of 500 degrees Fahrenheit, the high temperature Hastelloy filter begins to act as a reduction catalyst, reducing the NO₂ fraction of NOX to NO. This reduction reaction is **insignificant** at temperatures below 450 degrees, but gradually increases with temperature and becomes quite significant at temperatures in excess of 550 degrees. **Of course the total NOX concentration is not affected, since NOX is the sum of NO plus NO₂!**

The same reduction reaction of NO₂ to NO, but to a much smaller degree is also present, when an inconel or stainless steel probe is used. These materials contain nickel and maybe molybdenum that act as reducing agents above a certain temperature.

If you are interested in determining the **exact concentrations of NO and NO₂** in the stack, and the probe **temperature exceeds 450 degrees Fahrenheit** remove the Hastelloy sintered filter from the probe . The fiber filter located in the probe housing is adequate to remove any soot particles.

You should also avoid inserting long lengths of inconel or stainless steel probe in stacks exceeding 500 degrees F, if you wish to have an exact figure for the NO/NO₂ speciation. Instead, use a ceramic probe. In any case, please remember that there is no net loss or gain to the total NOX value, no matter which type of probe, or filter you use!

Please also keep in mind that a very small fraction of NO is oxidized to NO₂ during the transport of the sample from the probe to the analyzer. This is true of all analyzers and depends on the concentration of both NO and oxygen. In the ENERAC it is typically less than 3%.

In all cases the total NOX concentration is not affected by these reactions!

NOTE:

Please remember, you will loose a fraction of NO₂ and therefore of total NOX, only if your analyzer's transport system allows water condensation to occur, or the materials used in the sampling system retain some NO₂, which is known to be a "sticky" gas. **The ENERAC does not allow any of these losses to occur, because of its superior permeation drier based sampling system!**

APPENDIX F

INFRARED SENSOR OPTION

The Model 3000E emissions analyzer can be equipped with infrared sensor measurement capability for the measurement of three gases: carbon monoxide, carbon dioxide and hydrocarbons.

The infrared option has the following specifications:

GAS	RANGE	ACCURACY
CARBON MONOXIDE	0% - 10% 10% - 15%	3% relative 5% relative
CARBON DIOXIDE	0% - 16% 16% - 20%	3% relative 5% relative
HYDROCARBONS AS PROPANE	0 - 2000 PPM 2000 - 10,000 PPM 10,000 - 30,000 PPM	4 PPM or 3% relative 5% relative 8% relative

When the ENERAC is equipped with the NDIR (infrared) option, the keys on the instrument's face plate operate as follows:

A. DUAL RANGE SWITCHES

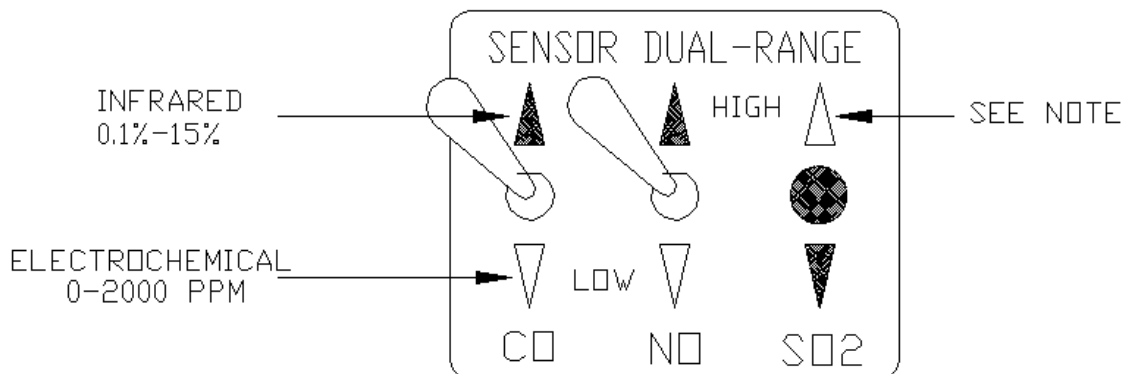

1. CO SWITCH:

When the LOW CO LED is ON, the ENERAC measures the carbon monoxide concentration using the installed SEM “electrochemical” CO sensor. In this case the range can be either 500 PPM or 2000 PPM CO depending on the PCM installed. Use this switch position for LOW CO measurements!

When the CO toggle switch is in the upper position and the “HIGH” CO LED is ON, the ENERAC measures the carbon monoxide concentration using the INFRARED CO sensor. In this case the CO range is 0.1% (1000 PPM) to 15% . Use this switch position for HIGH CO measurements, or for engine emissions.

NOTE 1: When the CO switch is in the “HIGH” position, the electrochemical SEM CO sensor (high sensitivity scale) is sealed off to prevent that sensor’s saturation!

2. SO₂ SENSOR READINGS

NOTE 2: The electrochemical SO₂ sensor does not operate as a dual range sensor for ENERACs using the infrared option. When the UPPER CO LED is ON, the SO₂ sensor is disabled and the display and printer will indicate “N.A.” (Not available). You can only make SO₂ measurements when the CO toggle switch is in the LOWER position.

The reason for disabling the SO₂ sensor is due to its small cross sensitivity to CO gas. When measuring high CO concentrations using the infrared CO sensor, you would obtain an erroneous SO₂ reading due to the high CO concentration. To prevent erroneous readings the SO₂ sensor is disabled.

B. KEYPAD SWITCHES

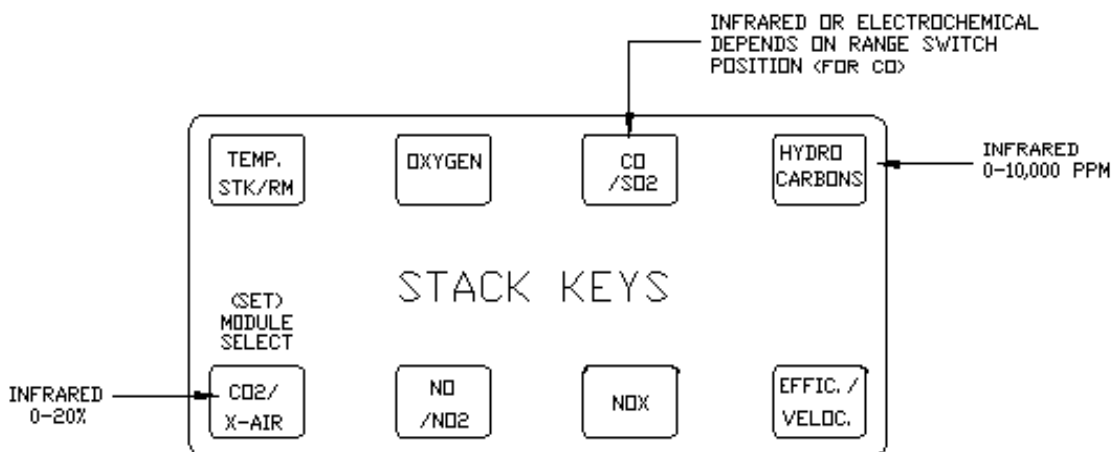

The figur

e above shows the function of the ENERAC keypad for the INFRARED option.

1. "Hydrocarbons" replaces the "combustibles" legend to indicate that combustible gases are measured by infrared technology, which does not respond to hydrogen gas.
- 2, The "CO/SO2" key functions in a way that depends on the setting of the CO toggle switch, as explained previously.
3. The "CO2/X-AIR" key measures the CO₂ concentration using the infrared sensor. Excess air is calculated from the CO₂ reading.

C. PRINTER OUTPUT

The ENERAC's printout is slightly different, when using the infrared option.

To prevent confusion about how the readings have been obtained, each printed parameter is followed by one of the following three comments:

- "(IR)" - denotes infrared (NDIR) type of measurement for this parameter
- "(e-chem)" - denotes electrochemical sensor measurement
- "(Calc.)" - denotes a computed parameter

D. OPERATION AND CALIBRATION

You must not allow dirt or condensation to enter the instrument. Infrared sensors cannot be saturated by excess gas, but must not get any of their optical surfaces dirty or wet.

To operate the ENERAC proceed as follows:

1. Connect the probe and sampling line to the analyzer.
2. Turn the analyzer on.
3. Press the "ENTER" key three times to bypass the information on the display regarding the SEM sensor modules.
4. The analyzer will automatically initiate the AUTOZERO countdown. (The Autozero countdown will be executed every time the analyzer is on! It cannot be by passed! This is a requirement of the infrared sensors. They must be zeroed every time the unit is turned on!)

NOTE : INFRARED SENSOR ERROR CONDITION:

If the analyzer receives no response from the infrared sensors during the autozero countdown, it will display the following “new” error message:

“NDIR ERROR”

You can bypass this error message by pressing the “ENTER” key. However, in this case, if you attempt to read any of the infrared sensors, the message “N.A.” - “not available” will appear on the display.

To calibrate the infrared sensors using span gas, follow the same procedures as listed in the “CALIBRATION” section of the manual. Make sure the CO range toggle switch is in the upper position.

IMPORTANT NOTE:

A 40 second autozero will be AUTOMATICALLY initiated when you attempt to calibrate any of the infrared sensors (CO, CO₂ or HC). DO NOT START FEEDING CALIBRATION GAS UNTIL THE AUTOZERO SEQUENCE HAS BEEN COMPLETED!!

The range of useable calibration span gases for the infrared sensors are:

CO:	1.125 % - 15.0 %
CO ₂ :	9.0 % - 20.0 %
Hydrocarbons:	450 PPM - 10,000 PPM

NOTE: You cannot use span gas with concentration LOWER than those listed above. This is a property of the infrared sensors.

If you wish to use a hydrocarbon span gas with concentration higher than that listed above, please contact the factory for a suitable modification to the software.